

REPORT BY THE UNIVERSITY OF WASHINGTON

Renewable Energy Options for Golden Gate National Recreation Area at Alcatraz Island

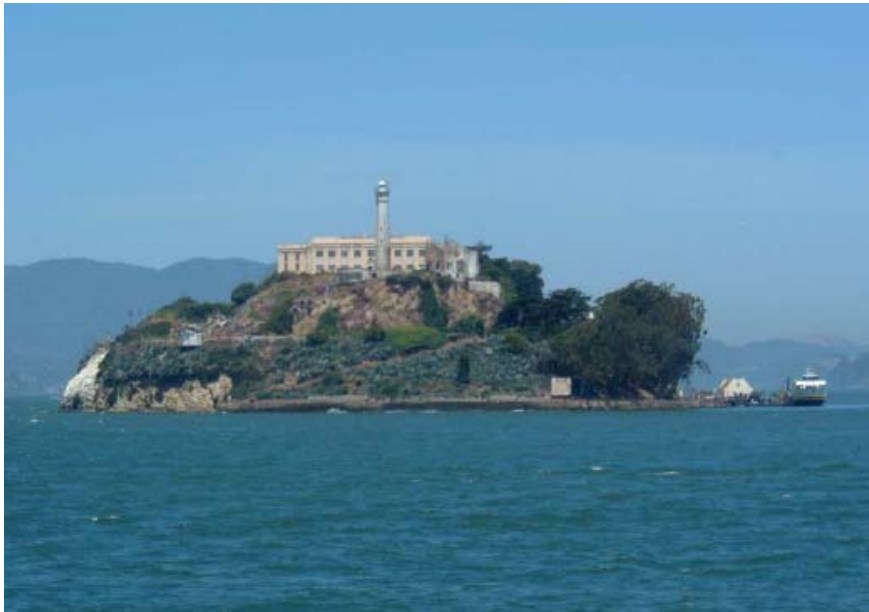

May 2008

Prepared for:

University National Park Energy Partnership Program
and
National Park Service

Prepared by:

Mary H. Hamman, K. Boyd Fackler, and Philip C. Malte
Department of Mechanical Engineering
University of Washington
Seattle, WA 98195-2600
Phone: 206.543.6851
Email: malte@u.washington.edu

Renewable Energy Options for Golden Gate National Recreation Area at Alcatraz Island

*Mary H. Hamman, K. Boyd Fackler, and Philip C. Malte
Department of Mechanical Engineering
University of Washington
Seattle, WA 98195-2600*

EXECUTIVE SUMMARY

This report is based on the Masters of Science (Mechanical Engineering) Thesis of Ms. Hamman completed in March 2008. Material on electrical details and wiring diagrams and on pumped storage seawater corrosion has been added. The report includes a comprehensive study of the existing energy situation at Alcatraz Island and the renewable energy opportunities available there. Alcatraz Island is part of the Golden Gate National Recreation Area in San Francisco Bay. As the site of one of the most notorious federal prisons, it is a significant piece of this country's history and a destination for over a million tourists each year. The island is not connected to the San Francisco power grid, and currently energy is provided by 210 kW rated diesel generators, one that operates all day, regardless of the energy demand, and one held as an alternative. The cost of electricity produced by the diesel generators is \$0.39/kWh, including fuel, transportation, maintenance and the emissions from the generators. With the increase in fuel cost and growing concern about greenhouse gas effects on the environment, the National Park Service is interested in finding alternative forms of power generation for the park.

The purpose of this study is to determine one or more alternative energy systems to be used at Alcatraz Island. A comprehensive energy analysis of the island has been performed, including an audit of all of the energy uses on the island. Several energy consumption reduction methods are explored and the possible daily energy savings are estimated. Possible renewable energy resources in the San Francisco Bay are identified and data have been obtained to characterize their yearly availability. The energy available from each resource has been calculated and the optimal renewable energy resource has been determined to be solar energy. Four different systems are designed, including two different capacity solar photovoltaic systems in combination with either diesel generators or grid electricity. Finally, an economic analysis of each solar photovoltaic system is performed to determine the resulting cost of electricity for each possible system.

Seven of the original buildings on Alcatraz Island, plus two modern restrooms, are currently functional and utilize power. Their uses vary between tourism, commerce, offices and facilities used by the National Park Service and the Golden Gate National Park Conservancy. The daily fuel consumption at Alcatraz

Island is 175 gallons, providing 2350 kWh of electricity each day. This divides into a daytime load of 154 kW and an evening load of 41 kW. It is not recommended to operate generators at below their rated capacity because their efficiency decreases and the engines deteriorate faster. The largest energy consumers on the island are the incandescent and halogen lighting, consuming 27.7% and 17.9% of the daily energy produced, respectively. By implementing a few very simple energy conservation methods, including turning off unnecessary lighting and incorporating energy efficient bulbs, the daily energy load at Alcatraz Island could be reduced by nearly 42.3% of the current load.

The three renewable resources available in San Francisco Bay are solar, wind, and tidal energy. Hourly solar and wind measurements have been obtained from the National Renewable Energy Laboratory website for San Francisco Airport. These data have been used to calculate the energy available each hour from both resources for an entire year. A full wind turbine array, 51 turbines, located on the roof of the Cell House could produce only 3% of the yearly energy demand at Alcatraz Island. In contrast, a large solar photovoltaic array, rated at 330 kW, could provide over 70% of the energy demand for the year. The energy output of a solar array depends on the amount of solar radiation available, causing a monthly energy production variation between 30% and 100% of the demand depending on the time of year. The National Oceanic and Atmospheric Administration has tidal current predictions of the maximum ebb and flood tides at several locations in the San Francisco Bay. This information has been used to predict the average power density of the tidal current at four locations near Alcatraz Island. The maximum power density of the tide near Alcatraz Island is 0.4 kW/m², but a tidal installation generally should have a power density of no less than 0.8 kW/m². Unless alternative data can be obtained that contradict the wind and tidal data presented in this report, neither should be considered for a renewable energy installation at Alcatraz Island.

After determining the most suitable renewable energy resource, the system has to be sized and designed. The solar photovoltaic array can be as small or large as the space available to accommodate the solar modules. The two potential locations for solar modules in this study are the Cell House and the New Industries Building located on the island. The New Industries Building has a usable roof area of 15,300 ft² and the Cell House has 43,000 ft² of free area. The two roof solar arrays explored originally in this report are rated at 100 and 330 kW. The daytime power load at Alcatraz Island is 154 kW, so a 100 kW rated solar array will never produce power in excess of the daytime load; however, a 330 kW system in midsummer will. This demonstrates the need for an energy storage system in combination with a renewable energy system. During the daytime, a 330 kW system can produce up to twice as much power as is needed, so that excess is stored until the evening when the sun is gone and the modules can no longer produce power. Even the 100 kW system would benefit by the inclusion of an energy storage system. A 100 kW solar energy system at

Alcatraz Island will always require a secondary energy system and a 330 kW solar array will require a secondary system to be used in the winter and on cloudy days. In this case, the diesel generators already located on the island will work in combination with the solar modules to power the island; this is called a hybrid diesel solar energy system. If there is no energy storage, then generators are used to make up any shortage between the power demand and the solar energy system production, which could be very small, causing the generators to operate at dangerously low speed. With an energy storage system, batteries could be used to supply the power deficit during low load periods and the generators would only be turned on to recharge the batteries at a rate close to the generator capacity. This reduces the run time of the generators and allows them to only be used at their maximum efficiency. A pumped storage solution also is considered for the island, but the water reservoir present is not large enough to fully meet the energy storage demand.

Another specification of the solar energy system is the tilt angle and orientation of the solar modules. The tilt of a solar module refers to the angle that it makes with the horizontal surface and its orientation pertains to the angle between the front edge of the module and true south. It is often beneficial to tilt solar modules in the direction of the sun; this allows better solar radiation exposure and greater energy production potential. Alcatraz Island is located at a latitude of 37°N of the equator, so the optimal yearly tilt angle of a solar module located there is 28° off of the horizontal and facing directly south. Placing the solar modules in this position increases the yearly energy production by 9.3% compared to horizontal panels. It is preferable to arrange solar modules in line with the walls of the building because more modules can be fit onto the roof area available; however, neither of the buildings of consideration on Alcatraz Island are oriented directly north-south. The Cell House is oriented at 45° west of south and the New Industries Building is at 30° east of south. In these cases, the energy production penalties caused by orienting the tilted modules in line with each building are a 2.7% energy reduction for tilted panels aligned with the Cell House and a 3.6% energy reduction for the New Industries Building.

The price of a high-efficiency 200 watt solar module is roughly \$1080, bringing the cost of a 100 kW solar array to \$540,000. Off-grid solar energy systems of this magnitude are not very common, so it has been difficult to locate manufacturers of power electronic components. The only company found that makes off-grid inverters of the required size is the Australian company SunEnergy. For a 100 kW solar installation, a 200 kW inverter is recommended. This allows room for expansion of the solar array, and it also allows the diesel generators to charge the batteries at close to their rated capacity of 210 kW. The cost of this inverter with the balance of the power electronics included is \$105,000. A solar array is a combination of multiple, smaller sub-arrays. The limitations on the size of a sub-array are dependent on the open circuit voltage and short circuit current of both the modules and the inverter, while the full array

is limited by the number of inputs that the inverter can accommodate. The solar modules considered for this project cannot be arranged with more than eight modules in parallel and 12 modules in series to match the 200 kVA SunEnergy Inverter and eight modules in parallel and 18 modules in series to match the 400 kVA inverter, which means that the arrays have to be sized in increments of 96 and 144. This changed the solar arrays of consideration into 115 kW and 346 kW rated systems. The remaining costs associated with the system are the solar module racks, the power conductors and the battery bank. The costs of the racking system and power conductors are minimal compared to the other components. The price of the battery bank and its 10 year replacement is \$541,400. The capital cost of a 115 kW rated system is between \$1,475,900 and \$1,485,300, and the cost of a 346 kW system ranges between \$3,036,800 and \$3,092,700.

The alternative to having diesel generators as backup for the solar energy system is to reconnect to the San Francisco power grid. This was the original source of energy for Alcatraz Island, so it is a logical consideration for this project. A grid connection could either be used in combination with a solar energy system or as the single source of energy for the island. A grid connected solar energy system removes the need for a secondary energy generation method and the need for energy storage, because any excess energy produced by the solar energy system can simply be put into the power grid to be retrieved when needed. The only impediment of this solution is the undersea power cable, which will have to be replaced and reinstalled on the sea bed. Including the copper for the cable and the installation, this would cost around \$2.5 million.

An economic analysis is performed for the two differently sized solar energy systems in combination with the diesel generator and the grid connection. For the diesel hybrid energy system, the cost of the fuel needed to supply the remaining energy demand and the resulting cost of the emissions are incorporated into the yearly operating costs. The cost of replacing the power cable is included in the capital investment of grid connected solar energy system analysis. For the purpose of comparison, the costs of energy for a stand alone diesel generator system and unaccompanied grid energy are calculated. The capital cost, annual capital, annual operating and energy costs of each system are shown in Table 1 below. The price range shown for each combination solar energy system is the maximum and minimum price based on the tilt angle and orientation of the panels. The system lifetime is 20 years. The analysis assumes a diesel price of \$3.00 per gallon (which was valid at the time of the cost analysis in autumn 2007).

Table 1: Cost Breakdown of the Six Prospective Energy Systems

Energy System Configuration & Size	Capital Investment (\$)	Annualized Capital Cost (\$/yr)	Annual Operating Cost (\$/yr)	Cost of Electricity (\$/kWh)
Hybrid Diesel Solar 115 kW	1,521,069 - 1,539,892	143,000 - 144,919	251,496 - 258,291	0.46 - 0.47
Hybrid Diesel Solar 346 kW	3,144,832 - 3,200,746	296,463 - 302,158	94,745 - 115,128	0.46- 0.48
Grid-tied Solar 115 kW	3,675,549 - 3,694,372	362,440 - 364,357	98,135 - 100,593	0.54
Grid-tied Solar 346 kW	5,049,312 - 5,105,227	490,438 - 496,133	42,338 - 49,714	0.63
Grid Energy Only	2,510,000	255,649	125,178 - 142,330	0.44 - 0.46
Diesel Generators Only	N/A	N/A	333,478	0.39

On a purely economic basis, diesel power generation is the best energy source. This is because the generators are already present and presumably paid for, so there is no capital cost to get the system established. There are risks associated with this system, however, including the unstable price of fuel and possible changes to the emission standards in the San Francisco Bay area. If there is either an increase in the price of fuel (as has occurred between autumn 2007, when the economic analysis was performed, and spring 2008, when this report is being issued) or the penalty for generator emissions, then this may no longer be the least expensive energy system available. Practically, grid energy is likely the most reliable and simplest energy source to maintain. Once the power cable is in place there would be little maintenance to be performed and the cost of grid energy is reasonably stable. However, that does not necessarily make it the best solution.

Solar photovoltaics could be an opportunity to educate thousands of people a day about clean, renewable energy. A solar energy system at Alcatraz Island could be a chance for the national government to lead by example and showcase its concern for the declining condition of the atmosphere. A renewable energy system would also reduce the amount of diesel fuel that is consumed, which will be beneficial with the prevailing fuel shortage and the decrease of pollution into the environment. The optimal system is one that minimizes energy cost, reduces diesel fuel consumption and incorporates renewable energy, which is true for both of the hybrid diesel-solar energy systems. The larger system may be more economical in light of increases in the cost of diesel fuel; however, either system is applicable for Alcatraz Island. A tidal energy system is still a possibility for Alcatraz Island if a high power density region can be confirmed. The National Park Service should select the most practical energy system for its operation and in line with its objectives and budget.

TABLE OF CONTENTS

EXECUTIVE SUMMARY	ii
LIST OF FIGURES	ix
LIST OF TABLES	xi
ACKNOWLEDGEMENTS	xii
INTRODUCTION	1
1 Alcatraz Island Overview	4
1.1 History	4
1.2 Description	6
2 Project Objectives	9
3 Alcatraz Island Energy Consumption	11
3.1 Existing Energy Generation Method	11
3.2 Energy Production by Diesel Generators at Alcatraz Island	12
3.3 Energy Load Profile	15
4 Energy Audit	17
4.1 Energy Consumption Distribution	17
4.2 Energy Conservation Methods and Savings	20
5 Solar Energy Assessment	22
5.1 Solar Resource	22
5.2 Solar Module Manufacturers	25
5.3 Solar Module Tilt Angles	27
5.4 Solar Power Availability	32
6 Wind Energy Assessment	43
6.1 Wind Resource	43
6.2 Wind Turbine Manufacturers	48
6.3 Wind Turbine Orientation and Type	53
6.4 Wind Power Availability	55
7 Tidal Energy Assessment	59
7.1 Tidal Resource	59
7.2 Tidal Turbine Manufacturers	61
7.3 Potential Tidal Turbine Location	63
7.4 Tidal Power Availability	64
8 Reconnect to the San Francisco Power Grid	66
9 Energy Storage	68
9.1 Battery Storage	69
9.2 Pumped Storage	70
10 Solar Energy System Design	76
10.1 Solar Energy Justification	76
10.2 Solar System Components	77
10.2.1 Solar Modules	77
10.2.2 Battery Bank	78
10.2.3 Inverter	80

10.2.4	Charge Controller.....	82
10.2.5	Power Conductors.....	82
10.2.6	Solar Module Support	83
10.3	Solar Array Design	84
10.4	Solar Energy Availability for New Industries Building	87
10.5	Solar Energy Availability for Cell House	88
11	Economic Analysis.....	90
11.1	Solar Energy System.....	91
11.1.1	Hybrid Diesel-Solar Power System	91
11.1.2	Grid-Tied Solar System.....	96
11.2	San Francisco Grid Power	99
11.3	Stand Alone Diesel Generator.....	100
12	Electrical Considerations, Details, and Wiring Diagrams	101
12.1	Overview	101
12.2	Solar PV Modules.....	101
12.3	Inverter	103
12.4	Battery Bank.....	108
12.5	The NEC	110
12.5.1	Cables and Over-current Device Sizing	110
12.5.2	Battery Bank Wiring Considerations.....	116
12.5.3	DC Grounding	116
12.5.4	Generators	119
12.5.5	Voltage Drop Considerations	119
12.6	346 kW PV hybrid System.....	123
13	Conclusions and Recommendations	124
	END NOTES	128
	REFERENCES	106
	Appendix A: Energy Consumption Calculations	114
	Appendix B: Summer Energy Demand	116
	Appendix C: Solar Energy Availability Analysis	123
	Appendix D: Wind Energy Availability Analysis	129
	Appendix F: Pumped Storage Capacity Analysis	132
	Appendix G: Economic Analysis – Annuity Method	134
	Appendix H: Wiring Diagrams for the 346 kW Solar array	137

LIST OF FIGURES

Figure Number	Page
Figure 1: Map of San Francisco Bay Including Location of Alcatraz Island.	1
Figure 2: Aerial View of Alcatraz Island.....	5
Figure 3: Building Layout on Alcatraz Island.	7
Figure 4: Daily Diesel Fuel Consumption for February 27 to March 26, 2007	13
Figure 5: Monthly Solar Radiation Measured at Alcatraz Island in 1995-1996	23
Figure 6: Monthly Solar Radiation Measured at SFO in 1995-1996	24
Figure 7: Diagram of the Solar Angles: θ_z , θ , β and γ	28
Figure 8: Required Space Between 28° Tilted Panels in Summer, Winter, Spring and Fall	30
Figure 9: Solar modules aligned with the Cell House long wall.....	31
Figure 10: Solar modules oriented true south on the Cell House	31
Figure 11: Average Hourly Solar Radiation for SFO in July.....	34
Figure 12: Average Monthly Solar Radiation at SFO	35
Figure 13: Monthly Solar Energy for a 100 kW Rated Horizontal Panel Solar System	36
Figure 14: Monthly Solar Energy for a 100 kW Rated Solar System Tilted at 28°	37
Figure 15: Monthly Solar Energy for a 100 kW Rated Solar System Tilted at 28° Oriented At 30° East of True South.....	38
Figure 16: Monthly Solar Energy for a 100 kW Rated Solar System Titled at 28° Oriented at 45° West of True South.....	39
Figure 17: Comparison Between Flat and Tilted Panels at Different Orientations	40
Figure 18: Monthly Solar Energy for a 330 kW Rated Horizontal Panel Solar System	41
Figure 19: Monthly Solar Energy for a 330 kW Rated South Facing Solar System Tilted at 28°	42
Figure 20: Examples of the Boundary Layer of Wind over Different Terrain.....	43
Figure 21: Average Daily Wind Speed at Alcatraz Island.....	44
Figure 22: Alcatraz Island Wind Speed Distribution	45
Figure 23: TMY2 Average Daily Wind Speed at San Francisco Airport.....	47
Figure 24: SFO Average Wind Speed Distribution from 1995-2005.....	47
Figure 25: Swift Rooftop Wind Turbines	48
Figure 26: ARE 110 Wind Turbine	49
Figure 27: Bergey Windpower Turbines (left: 1 kW, right: 7.5 kW)	50
Figure 28: Windside WS-C4 Turbine	51
Figure 29: PacWind Turbines (left to right: SeaHawk, Delta I, Delta II)	52
Figure 30: Drag and Lift Wind Turbines.....	54
Figure 31: Horizontal Axis Turbine Array Located on the Cell House Roof.....	55

Figure 32: Small Vertical Axis Turbine Array Located on the Cell House Roof ...	56
Figure 33: Large Vertical Axis Turbine Array on the Cell House Roof	57
Figure 34: Monthly Wind Energy Production for a 51 Turbine Installation.....	58
Figure 35: Bathymetry for west end of San Francisco Bay with NOAA stations noted.	60
Figure 36: TRIM Model Prediction for Ebb Tide on January 20, 2008	61
Figure 37: Verdant Power Free Flow Turbines	62
Figure 38: Vertical Axis Gorlov Helical Turbine.....	63
Figure 39: Bathymetry of San Francisco Bay around Alcatraz Island.....	64
Figure 40: Water Tower on Alcatraz Island.....	71
Figure 41: Diagram of the Components and Connections of a PV System.....	80
Figure 42: Current versus Voltage Curve for a 200 W Sanyo Solar Module.....	86
Figure 43: A CAD depiction of Alcatraz Island from the North.	102
Figure 44: Generalized diagram of renewable/genset interaction for varying electric load.	104
Figure 45: A model representation of a typical 5 day charging/discharging schedule for Alcatraz.	106
Figure 46: Battery Bank SOC corresponding to the charging/discharging cycle in Figure 45.....	106
Figure 47: Sub-array for the 115 kW system.....	115
Figure 48: Battery bank wiring for the 115 kW array.....	118
Figure 49: DC to AC wiring diagram for the 115 kW system.	121
Figure 50: Inverter to Generator Wiring Diagram for the 115 kW system.....	122
Figure 51: Main Generator Bus Diagram for the 115 kW system.	123
Figure 52: Sub-array for the 346 kW system.....	138
Figure 53: Battery bank wiring for the 346 kW array.....	140
Figure 54: DC to AC wiring diagram for the 346 kW system.	141
Figure 55: Inverter to Generator Wiring Diagram for the 346 kW system.....	142
Figure 56: Main Generator Bus Diagram for the 346 kW system.	143

LIST OF TABLES

Table Number	Page
Table 1: Cost Breakdown of the Six Prospective Energy Systems.....	vi
Table 2: Caterpillar 3306B Engine Performance.	14
Table 3: Alcatraz Island Energy Demand and Daily Load.....	19
Table 4: ARE Systems and Costs	50
Table 5: Bergey Systems and Cost Breakdown.....	51
Table 6: PacWind Systems Cost Breakdown	52
Table 7: Solar System Location, Size and Layout.....	85
Table 8: Solar Array Size and Corresponding Power Rating.....	87
Table 9: Solar System Power Output for New Industries Building.....	88
Table 10: Solar System Output for Cell House Building	89
Table 11: Diesel Emissions and Costs	92
Table 12: Economic Analysis for a 115 kW rated Hybrid System	93
Table 13: Economic Analysis for a 346 kW rated Hybrid System.....	95
Table 14: Economic Analysis for a 115 kW Grid-Tied Solar System.....	97
Table 15: Economic Analysis for a 346 kW Grid-Tied Solar Energy System.....	98
Table 16: Economic Analysis for Stand Alone Grid-Tied Energy System	99
Table 17: Economic Analysis for Stand Alone Diesel Generator Energy System	100
Table 18: Design Specs for the Sanyo HIP-200BA3 Module.	101
Table 19: Cost Breakdown of the Six Prospective Energy Systems	126

ACKNOWLEDGEMENTS

The authors would like to extend their sincere gratitude to everyone who aided in the successful completion of this study and report. Foremost, thanks to the University National Park Energy Partnership Program (UNPEPP), the National Park Service (NPS) and the Bonneville Power Administration (BPA), whose financial support made this study possible, and to the Pacific Northwest Cooperative Ecosystems Studies Unit (PNW CESU). A special thanks to Steve Butterworth and Laura Castellini with the National Park Service, who provided invaluable knowledge and insight during the study. Dr. Andy Walker of National Renewable Energy Laboratory (NREL) has been extremely accommodating, providing information and data that have been critical to the project. The helpfulness and cooperation of Patrick McAllister at the Golden Gate National Conservancy and of Ricardo Perez with the National Park Service are greatly appreciated. Special thanks to Scott Gates at Idaho Power, whose knowledge and experience with similar hybrid diesel solar energy systems has been invaluable, to Brian Polagye, who provided his time and knowledge for the assessment of the tidal resource, and to Jessica Theilmann, who provided the information on corrosion and its control for the pumped storage system. Finally, thanks are extended to Professors Teodora Shuman and John Kramlich for serving and providing guidance on Ms. Hamann's Masters of Science Committee.

INTRODUCTION

Alcatraz Island, commonly referred to as “The Rock,” is a relatively small, natural island located in the San Francisco Bay just three kilometers north of San Francisco and east of the Golden Gate Bridge. Its location is indicated in Figure 1 below. Over the last two hundred years this island has maintained a lighthouse, been employed as a military fortress, a military prison, a federal prison, been the scene of a Native American occupation and is currently a part of the Golden Gate National Recreation Area.

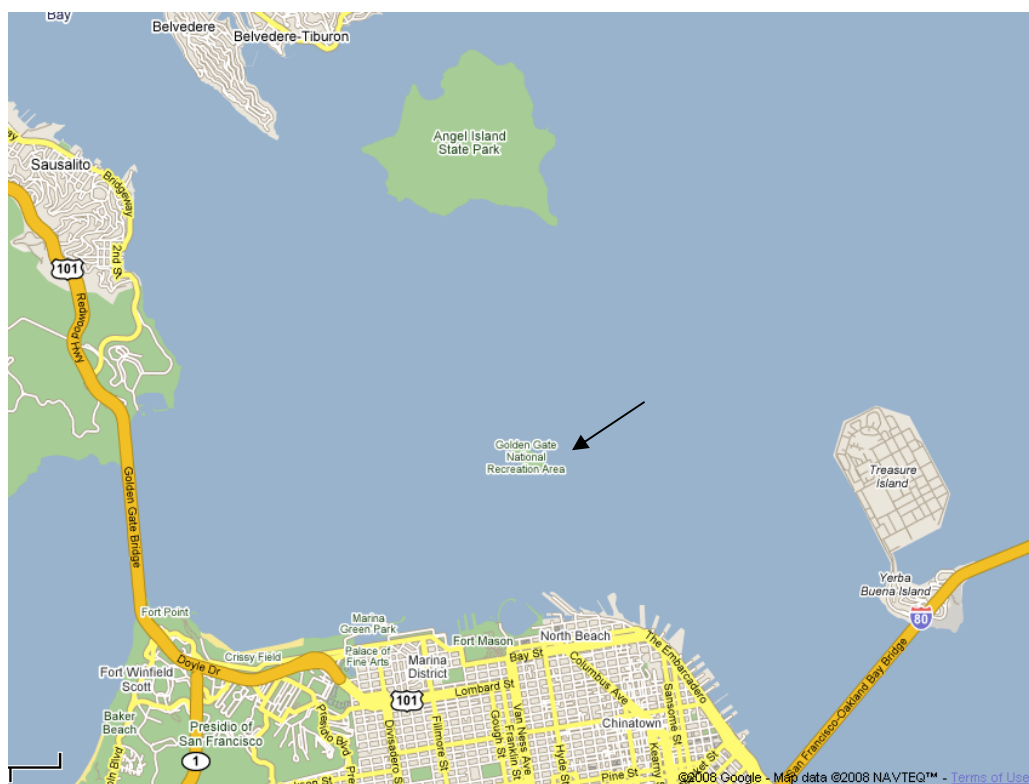

Figure 1: Map of San Francisco Bay Including Location of Alcatraz Island.¹

As part of a national recreation area, Alcatraz Island hosts over one million visitors each year. People come to the island to experience the historical atmosphere of the former federal prison and revel in the natural beauty of the area. While at the park, visitors can view a film about the history of the island,

take an audio tour of the Cell House, purchase memorabilia from the variety of shops or walk around the grounds and enjoy the wildlife and plants that inhabit the island. It is also possible to rent some of the facilities for private functions. Between the National Park Service and the concessionaire, who manage the shops and tours, there are 120 employees on the island each day who maintain the facilities and the tourism.

Between the employees and thousands of visitors, a considerable amount of energy is consumed on the island each day, with tourism only increasing each year. As Alcatraz Island has not been connected to the San Francisco power grid since 1970, all of the energy is produced with diesel generators. Originally, 80 kW generators were employed but were upgraded to 210 kW units after 2002 to keep up with the increase in energy demand. Diesel fuel, to be used in the generators, is transported to the island twice a week for a total of 63,875 gallons per year at a cost of \$176,000 in fuel alone. This does not account for the cost of delivery of the fuel to the island or the maintenance on the generators, nor does it consider the detriment to the air caused by burning diesel fuel in the transportation boats and in the generators.

With growing concern about greenhouse gas emissions, it is likely that the emissions standards in the San Francisco Bay area will become more stringent in the upcoming years; however, as tourism on the island increases, it can only be assumed that power consumption is going to increase. These two factors express the need to find a cleaner, more efficient energy solution for Alcatraz Island. The University of Washington was requested to conduct a renewable energy study and energy audit of Alcatraz Island. The purpose of this study is to identify techniques to reduce energy consumption and find an alternative to diesel generators for powering the island. Although it may not be possible to replace diesel generators entirely, the amount of energy they produce can be

offset with clean, renewable energy. The park could also be reconnected to the San Francisco power grid, but at significant expense.

This report explores the renewable energy opportunities available in San Francisco Bay and identifies possible solutions. Also included is a conceptual design of the solar photovoltaic energy system and economic analysis to accompany the energy solutions.

1 Alcatraz Island Overview

1.1 History

For such a small body of land, Alcatraz Island has a unique and complicated history which has helped shape the history of the United States. The island was named “isla de los Alcatrazes” by the first Spanish Explorers for the many pelicans that inhabit its shores and was later shortened to Alcatraz. The premier use of the island was as a station for a navigational lighthouse used to accommodate the large influx of people coming to California as a result of the discovery of gold in the 1840’s.² Due to its strategic location in the San Francisco Bay, Alcatraz was soon realized as a military defensive position and an army fortress was constructed in the early 1850’s to defend San Francisco from possible attacks.³

Alcatraz Island became a useful instrument during the Civil War while California was populated with those sympathetic to both causes. Although the island was never attacked, it was used to imprison Confederate supporters and soon removed any ambition of the Confederates of taking California for their side. After the end of the Civil War, Alcatraz Island lost its usefulness as a military fort and became principally a military prison for those charged with treason, mutiny and high crimes. The island remained under control of the United States military until 1934 when it was transferred to the Bureau of Prisons to be used as a High Security Federal Prison. In the meantime, the original fortress was leveled to the first floor and a full size cell house was constructed on top using prisoner labor. This building was the largest reinforced concrete building to date including 600 cells, each with plumbing and electricity that was transferred from the mainland by an underwater cable sitting on the sea bed.

As a Federal Prison, Alcatraz Island housed some of this country's most notorious criminals and is responsible for several legends regarding the many escapes attempted over the years. It was also during this era that many of the buildings that are present today were constructed and can be seen in Figure 2. The barracks, which had originally been used by the military, were converted into housing for the prison guards and their families as well as the addition of four houses, a duplex and three apartments. The Model Industries Building that had been used by military prisoners for vocational trades was insufficient at restraining the federal prisoners and was replaced by the New Industries Building in the early 1940's.⁴ The main cell block also had to be remodeled in order to accommodate its new tenants. The cells were reduced in number from 600 to 336 and reinforced with "tool-proof" steel bars, while gun galleries were installed on either side of the cells. Although the innovative security measures along with the swift tide and cold water were supposed to render the island inescapable, there were still 5 escapees whose bodies remain unaccounted.



Figure 2: Aerial View of Alcatraz Island.⁵

Alcatraz Island was employed as a Federal Prison from 1934 until 1963 when it was shut down due to its declining condition and increased cost of operation. From the time the ferry left with the last prisoner, the island remained vacant until 1969 when it became the scene of a large Native American occupation that lasted 19 months. The island still contains evidence of their occupation, including red paint that declares “Indians Welcome” at the dock and the burnt remnants of three buildings. It was during this period that the under-sea cable that supplied power to the island was severed. The occupation eventually ended in 1971 and the island was given to the NPS in 1972 to become part of the Golden Gate National Recreation Area. Today, Alcatraz Island is a very popular tourist destination for people from all over the world, drawing thousands of visitors each day.

1.2 Description

There are seven original buildings that remain intact on the island. These are the Cell House, Barracks, Sally Port, Storehouse, Power Plant, Model Industries Building and the New Industries Building. Each building and its relative orientation can be seen in Figure 3 below. In the figure, the New Industries Building is simply labeled as the Industries Building.

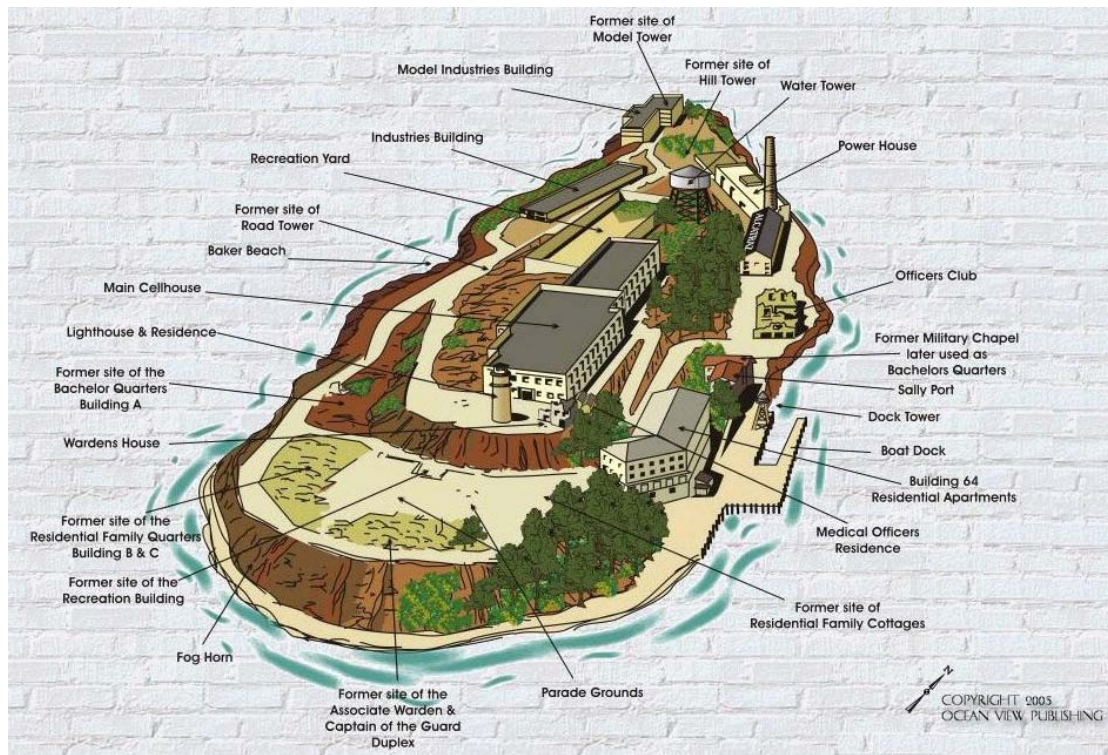

Figure 3: Building Layout on Alcatraz Island.⁶

When the ferry arrives at Alcatraz Island, all of the passengers gather at the dock area where they receive a short orientation and are then sent to explore the island. The first stop is the theatre in the Barracks building where people can view a short film about the history of the island or purchase memorabilia in the gift shop. There are three display rooms, well lit by track lighting, filled with relics from the prison era of the island. The Barracks building is also the residence of several offices used by both the NPS and the Golden Gate National Park Conservancy (GGNPC), which is responsible for all of the commerce on the island. From here, people make the ascent up to the Cell House.

Although the Cell House is no longer used to house criminals, it accommodates thousands of people each day. The main cell block is illuminated by a combination of several hundred compact fluorescent light (CFL) bulbs and incandescent light bulbs. Visitors are granted access to the main cell block as

well as the dining area, prison guard offices and exercise yard, all while listening to an audio tour guide provided at the “prisoner check-in” area on the first floor. When done viewing the Cell House, tourists can shop at the newly installed bookstore located on the first floor below the dining area. In contrast to the main cell block, the bookstore is very modern and includes hundreds of halogen track lights, flat screen televisions and cash registers. Very few visitors are granted access to the chapel and storage rooms, located above the guard offices, or to the original first floor of the “citadel” located below the cell block, otherwise known as the dungeon for extremely disobedient inmates. The Cell House contains additional offices for the NPS and GGNPC.

The remaining buildings on the island are used by the NPS for the operation of the park, or not at all. The Sally Port, next door to the Barracks, is used by the NPS as a workshop for performing any necessary repairs or maintenance. The Power House, located at the north end of the island, contains the generators that power it and is off-limits to tourists. As implied by its name, the Store House is used to store equipment for the NPS and sits next to the Power House. Due to its deteriorated condition, the Model Industries Building residing at the north-west tip of the island is not used anymore. The New Industries Building is becoming popular as a venue and can be rented out for conferences or events. As this use increases, the NPS will install a heat exchanger on the generators and supply heat to this building. The remaining structures on the island include the burnt remnants of the Warden’s House and Officer’s Club, the non-functional Water Tower and the functional Lighthouse.

2 Project Objectives

The purpose of this project is to analyze the current energy usage and production methods at Alcatraz Island National Park, assess the renewable energy opportunities located in San Francisco Bay, and determine the most efficient and economical renewable system possible. Renewable energy systems produce power from natural resources, such as sunlight, wind, hydro, geothermal or biomass. With the limited supply of fossil fuels and global climate changes occurring due to greenhouse gas emissions, it is becoming important to find clean, alternative methods of energy generation. A hybrid system uses part renewable and part non-renewable energy to provide power to a site. The first step is to determine how much energy is being used, and when and where it is being used on Alcatraz Island. Based on the current energy generation methods and fuel consumption, the daily energy load at the park is determined. An energy audit of the island is then conducted, and all of the main energy users are identified. The purpose of this is to verify the energy load at the park and determine the load profile, specifically, the high and low loads through the day. Next, energy conservation solutions are recommended.

The second aspect of the project is to determine the best renewable energy resource available to the island and design a corresponding renewable energy system. Three renewable energy resources are identified in the San Francisco Bay area: solar, wind and tidal. Information is then gathered for each of these to determine how much energy can be harnessed from each. A resource has to be present in order to induce the renewable system to generate power; however, natural resources such as sunlight and wind are not available all of the time nor are they predictable. This makes it necessary to obtain data that indicate how often a resource is available in order to determine how much energy can be produced by it throughout the year. A renewable energy system does not just

consist of a solar module or a turbine by itself, but also requires an energy storage system to accompany it, unless the site is connected to a power grid where any excess energy produced can be displaced until it is needed. This means that energy storage solutions have to be considered for the installation of a renewable energy system at Alcatraz Island.

Once the renewable energy system and accompanying energy storage system are determined, an economic analysis has to be conducted. A comparison is made between two different sized renewable systems having either generator backup and energy storage or a grid connection. The possibility of reconnecting to the San Francisco power grid and purchasing all of the energy is also considered. This is necessary for determining the overall cost of energy for the system and for assisting the NPS in deciding if renewable energy is cost competitive with respect to reestablishing the grid power.

3 Alcatraz Island Energy Consumption

3.1 Existing Energy Generation Method

The current method of producing electricity at Alcatraz Island is with either of two Caterpillar 210 kW diesel generators. The generators are run for intervals of one month and are then switched to provide routine maintenance on the inactive generator. Thus, effectively, Alcatraz Island runs on one 210 diesel generator. The diesel fuel is delivered to the island at the dock and transported through a pipe to a 3000 gallon storage tank located next to the Power House at the north end of the island. Although this was not the original method of powering the island, generators have been used since the Native American Occupation of Alcatraz Island when the under-sea cable was severed and attempts to repair the cable were unsuccessful. From the park opening until around 2002, Alcatraz Island used two 80 kW generators, but had to upgrade with the increased energy demand. The 80 kW generators are still functional and available for use as backup on the island.⁷

Although generators are reliable and relatively efficient at producing electricity, they have several disadvantages. Diesel generators tend to produce a lot of noise, detracting from the ambiance of the island and disturbing the wildlife that inhabits it. A second issue is the transportation of fuel to the island twice a week with the possibility of fuel spill into the bay. Diesel fuel cannot be transported to Alcatraz Island on the same boat as passengers, so a separate vessel has to be sent to the island specifically for this purpose, consuming ten gallons of fuel per trip.⁸ The greatest problem, however, is the high emissions associated with diesel generators. The exhaust emissions from the generators are considered a point source of pollution that may be subject to more stringent regulations by the Bay Area Air Quality Management District as the agency tries to reduce the

carbon footprint in the bay. For every 1000 gallons of diesel fuel burned, there are 11.2 tons of carbon dioxide (CO₂), 575 lbs of nitric oxide and nitrogen dioxide (NO_x), 28.5 lbs of sulfur dioxide (SO₂) and smaller quantities of other harmful substances emitted into the atmosphere.⁹ Each pollutant has a cost associated with it, helping justify the installation of renewable, non-polluting energy systems.

In addition to installing a renewable energy system to offset the use of the diesel generators, the NPS plans to reduce emissions on the island by replacing diesel fuel in the generators with biodiesel. Their intention is to start with B20 (20% biodiesel with 80% diesel) and, if successful, consider moving up to B100 (100% biodiesel). Aside from being carbon neutral, studies have indicated that biodiesel produces significantly less carbon monoxide (CO), hydrocarbons (HC) and particulate matter than petroleum diesel, however, the NO_x production can increase. Although the University of Washington is not responsible for this aspect of the project, it explored the possibility of using biodiesel and biodiesel blends in the generators at Alcatraz Island. It investigated the measures that will need to be taken to ensure that the generators can support biodiesel and examined particulate filters for reducing engine emissions. Additional study regarding the condition of the Alcatraz fuel storage tank and piping will need to be conducted before the system can contain biodiesel. An account of the UW investigation can be found in the UW UNPEPP quarterly report for July, 2007.¹⁰

3.2 Energy Production by Diesel Generators at Alcatraz Island

Before a renewable energy system can be designed for a location, it is necessary to assess how much energy is being consumed on a daily basis. Since Alcatraz Island is powered by a diesel generator, the island energy consumption is the same as the generator production. There is no meter or record of how much electricity the generators at Alcatraz Island produce hour by hour; however, they

do maintain a log book that records the amount of diesel fuel in the tank each day, when fuel is delivered and how much. While visiting the Island in March of 2007, Steve Butterworth took photographs of the diesel log book for that month.¹¹ The records indicated that 600 gallons are delivered to Alcatraz Island twice a week, making a total of 1200 gallons each week. The daily fuel consumption for the period of February 27 to March 26 can be seen in Figure 4 below. This information is used to calculate the amount of electricity produced each day based on the efficiency of the diesel generators and the lower heating value of diesel fuel.

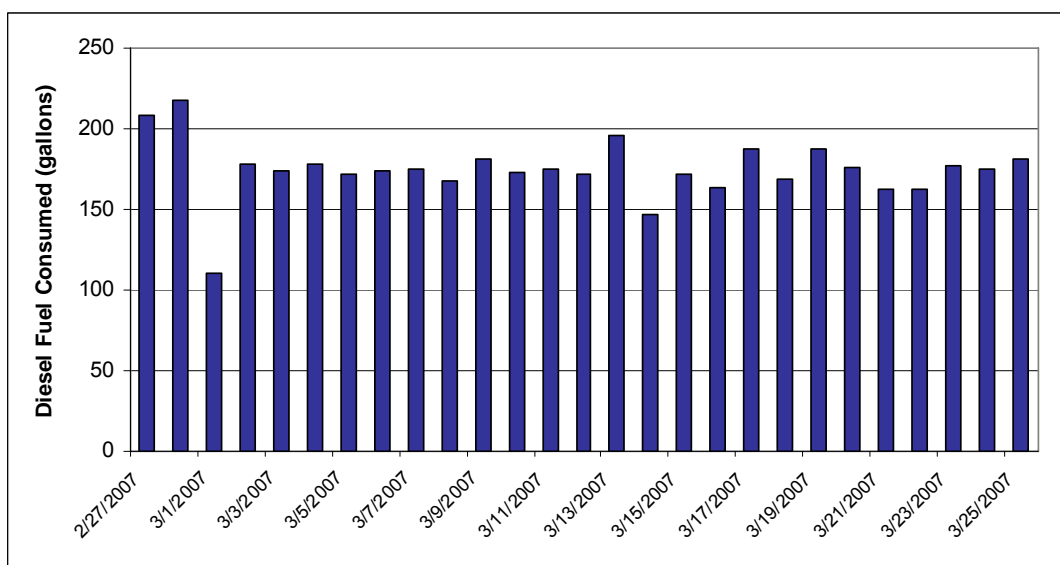

Figure 4: Daily Diesel Fuel Consumption for February 27 to March 26, 2007

The generators being used to power Alcatraz Island are two Caterpillar 3306B engines that are alternated monthly. These generators are rated at 210 kW, which is their maximum power output. Generators tend to produce energy more efficiently as they operate closer to their rated power. The specification sheet for the Caterpillar 3306B is used to compute the power output of the generators from the energy available from diesel fuel. The efficiency of the generator at quarter-interval loads are calculated and shown in Table 2.¹² The calculated efficiency

only applies under specific conditions, with the actual power output or fuel consumption varying up to 3% based on temperature and humidity.

Table 2: Caterpillar 3306B Engine Performance.¹³

Engine Load	Brake Power (kW)	Diesel Consumed (gph)	Energy from Diesel Fuel (kWh/hr)	Generator Efficiency
100%	205	14.3	523.66	39.1%
75%	153	10.8	395.49	38.7%
50%	103	7.3	267.32	38.5%
25%	53	4.2	153.80	34.5%

The rated efficiency of the generator ranges between 34.5% and 39.1%, depending on the load. Although there is slight variation from day to day, the average fuel consumption on the island is 175 gallons per day or 7.3 gallons per hour. This fuel consumption rate corresponds to a 50% load on the generator and 38.4% generator efficiency.¹⁴ This assumes a constant daily load, which is clearly not the case when the island is occupied for 12 hours and vacant for the remaining 12 hours. It is determined that the generators operate at around 75% capacity during the daytime and 25% during the evening, which corresponds to respective efficiencies of 38.7% and 34.5%. Other sources of power loss are to heat, caused by friction in the gear box and resistance in the transmission lines, and by the generator operating under non-ideal conditions.¹⁵ As a result of these factors, a conservative efficiency of 34.5% is used for the analysis. Once the generator efficiency is known, it is possible to convert fuel consumption into power using the lower heating value and density of diesel fuel (see Appendix A for calculation). The average power load at Alcatraz Island is 98 kW, and the daily electrical energy consumption is 2350 kWh. In order to verify this energy consumption calculation, an inventory of all of the power drawing items on the island, including their wattage and hours of use per day, is compiled and summed. The results of the energy audit compare favorably with the values obtained using diesel consumption and are discussed in Section 4.

The marine rate for diesel fuel in March of 2007 was \$2.72 per gallon, not including the cost of delivery to the island or the \$0.5 million retrofit to the vessel that transports the diesel.¹⁶ This corresponds to a yearly cost of \$176,000 for diesel fuel alone, or \$0.21 per kWh electrical energy for fuel. This energy rate does not account for the cost of operating and monitoring the diesel generators, in order to ensure that they are functioning properly, or for the routine maintenance that is performed monthly. Also excluded is the cost of the pollution on the environment in the form of CO₂, SO₂ and NO_x, caused by burning diesel fuel. A detailed economic analysis, including each of these factors, is performed in Chapter 11.

3.3 Energy Load Profile

It is not only important to know the average daily power draws of a system but the corresponding daily and yearly peaks and dips in the load. Alcatraz Island is open every day of the week for visitors, so there is not a decrease in energy consumption from the weekdays to weekends. The hours of operation for the National Park Service are from 9:00 am to 9:00 pm every day, year round.¹⁷ The Golden Gate National Park Conservancy (GGNPC), who manage the bookstore and gift shops, work from 8:45 am to 9:30 pm on the weekdays and 8:45 am to 6:45 pm on the weekends during the summer and for two fewer hours each day during the winter schedule.¹⁸ This means that the island is operational for 50% of the day during the summer and 40% of the day during the winter.

There is a slight increase in energy consumption during the winter, even though the park is open for fewer hours, which is likely due to the increased use of electric wall and space heaters. This difference is minimal, however, compared to the significant difference between the daytime and evening energy loads observed on the island. By knowing the hours of operation of the island and

which and when equipment is used, it is possible to distinguish the daytime from the evening load. Roughly 79% of the total daily energy consumption occurs during business hours, leaving 21% remaining for the evening and night. This corresponds to a daytime load of 153.8 kW and a 41.4 kW nighttime load. The 41.4 kW nighttime load has some serious implications, as it is less than 25% of the generator's rated power and would be even smaller if unnecessary lights didn't remain lit in the Cell House to maintain this load. A generator operated at too low of a load loses efficiency, as seen in Table 2, and degrades faster. However, keeping an artificial load on the generator wastes fuel and generator run time. This report explores possible solutions to this problem.

4 Energy Audit

4.1 Energy Consumption Distribution

The easiest way to become more energy and environmentally friendly is to make reductions on the demand side, rather than improve the supply side. As mentioned in Section 3, an inventory of all of the appliances and equipment on the island is compiled, including wattage and hours of daily use. This is done in order to confirm the daily energy load on the island and discover where all of the energy is going. This also helps identify the main power users in order to determine where changes should be made. The inventory is compiled using several sources. A trip to Alcatraz Island in July, 2007 provided a first hand view of the operation and insight into what kind of and how much equipment is being used in the offices and tourist areas. Since there are two independent outfits working out of Alcatraz Island, the NPS and the GGNPC, each had to be contacted to obtain information regarding their work schedule and all of their office equipment. Including employees from both groups, there are 120 people working on the island each day. Supplementary information was taken from an energy efficiency study conducted in 1996 by the Lawrence Berkeley National Laboratory¹⁹ and an inventory conducted recently by the NPS.²⁰ Diesel consumption is only known for the month of March, and there could be variances depending on the season that this number does not reflect; however, it should provide an average yearly consumption. The energy audit performed does consider the different work schedule observed during the winter versus the summer as well as the use of any electric heaters to warm the offices during the colder months.

A complete inventory of equipment, wattage, location and hours of use can be seen in Appendix B, with a summary of the results listed in Table 3. The daily

energy consumption calculated from the energy audit of 2361 kWh in the summer months matches very well with 2350 kWh per day, calculated using diesel consumption. There is an observed increase of 7.8% energy consumption during the winter months, bringing the daily consumption to 2546 kWh. The greatest energy consumers on the island, using 27.7% of the daily energy load, are the incandescent light bulbs, located in the various offices and illuminating the Cell House walls, ceilings and cells themselves. The halogen flood lights located in the bookstore and two gift shops are the second largest consumer, using 17.9% of the total daily load on the island. Although the park is open for fewer hours during the winter season, the increased use of electric heaters more than makes up for the decreased use of lighting and equipment, consuming 11.1% of the daily load. In descending order, the next greatest power consumers are the water heater, compressor, fluorescent lights and hand dryers in the bathrooms.

Table 3: Alcatraz Island Energy Demand and Daily Load.²¹

Appliance/Equipment	Quantity	Summer Daily Consumption (kWh/day)	Winter Daily Consumption (kWh/day)
Air Curtain	1	14.4	14.4
Beverage Cooler	1	6	6
Cash Register	6	10.8	8.64
CFL Bulb	113	40.54	40.4
Change/Bill Counter	3	0.96	0.6
Coffee Maker/Urn	5	42	36
Compressor	4	103.68	103.68
Computer	21	43.2	43.2
Copy Machine	1	3	3
Electric Car/Tram	5	60	60
Electric Heater	16	0	282
Electric saw	1	Negligible	Negligible
Elevator	2	36	36
Exit Sign	10	12.48	12.48
F32T8 Light Fixture	80	76.54	40.32
F40T12 Light Fixture	43	41.77	36.85
Fax Machine	1	2.88	2.88
Freezer	2	28.8	28.8
Halogen Flood Lamp	597	424.46	413.81
Hand Dryer	6	72	72
HID	13	55.8	55.8
Incandescent Bulb	518	654.96	651.58
Light House Lamp	1	36	36
Light House Motor	1	60	60
Microwave	6	18	18
Monitor	21	37.8	34.56
MP3 Charger	1	48	48
PA System	1	0.53	0.528
Printer	15	27	23.4
Projection System	4	96	76.8
Refrigerator	5	70.8	70.8
Speakers	16	3.84	3.07
Sump Pump	4	38.4	38.4
Telephone	12	7.2	7.2
Television	10	19.86	16.14
Toaster/Toaster Oven	6	15.6	15.6
VCR	2	0.552	0.552
Visitor Computer	2	3.6	2.88
Water Cooler/Heater	1	6	4.8
Water Heater	4	122.4	122.4
Water Pump	2	19.2	19.2
Welder	1	Negligible	Negligible
Daily Total		2361.048	2546.774

4.2 Energy Conservation Methods and Savings

There are many ways to decrease one's energy footprint, ranging from simple actions like turning off lights to installing an energy management system that can shut off the light and heat to a room when no one is inside and shut down equipment when it is not being used. It is wasteful to throw out and replace all of one's appliances with more energy efficient products, but there are ways to decrease energy consumption and eventually phase out antiquated equipment. For example, as incandescent light bulbs burn out, replace them with high efficiency compact fluorescent light (CFL) bulbs or install heat detecting wall switches that recognize when a room is occupied and adjust the light accordingly. Also, a lot of computer equipment and appliances still draw power when they are turned off, so it is wise to unplug such equipment or turn off the power to that outlet if it is not going to be used for an extended period of time. One point of dispute is whether it is better to turn a computer off over long periods of no use. Most modern computers have the option to sleep or hibernate, which essentially shuts them down and reduces their power draw to 8-15 W. This is a reasonable option if a computer is not going to be used for a couple hours; otherwise, it is preferable to turn a computer off overnight or for eight or more hours of inactivity. By no means should a computer sit idle for an extended period of time with a screen saver running, and the monitor should at least be turned off if not in use.²²

One of the most wasteful practices at Alcatraz Island is in keeping all of the lights in the Cell House on all night to keep a reasonable load on the diesel generator. Currently the evening power load at Alcatraz Island is 41.4 kW, which is less than 25% of the generator capacity and still unnecessarily high. By including some type of energy storage system that the island could run off of in the evening, the generator and the lights in the Cell House could be turned off and the load would

decrease to 17.5 kW. This would result in a 12% energy savings each day.

Another option is to transfer to one of the 80 kW rated generators for the nighttime load. In this case, only a 20 kW load would have to be maintained on the generator to keep it at 25% of its rated capacity. Before this is implemented, a comparison should be made between the efficiencies of the two sized generators at 25% capacity to confirm the fuel savings.

Several other energy saving methods are considered to determine the amount by which Alcatraz Island could reduce its daily energy consumption. First, all of the 52 W incandescent light bulbs could be replaced with 13 W CFL bulbs, the 100-150 W with 24 W, and all the 200-300 W with 40 W. Next, the halogen flood lights, presumably rated at 50 W, could be exchanged for equivalent energy saving spotlights, which only draw 11 W and have a lifetime of 15,000 hours.²³ A dimming spotlight could also be installed, which adjusts its output with respect to the amount of natural light available in a room, reducing the consumption further. The 52 W rated exit signs could be replaced with 10 W LED signs that can last up to 100 times longer.²⁴ Already, 80 of the fluorescent fixtures have been replaced with lower wattage bulbs and electrical ballasts to limit their electrical current, so the remaining 39 fixtures could incorporate this.²⁵ The result of implementing these four replacements and turning off all unnecessary lights in the evening is an energy consumption reduction of 42.3% per day. This breaks into a daytime power load of 97 kW, an evening load of 16.1 kW and a total daily energy consumption of 1361 kWh. This 42.3% energy demand reduction corresponds to an equivalent reduction in fuel consumption and a savings of \$74,300 per year in fuel alone (based on an autumn 2007 fuel price of \$3/gallon).

5 Solar Energy Assessment

5.1 Solar Resource

A photovoltaic (PV) cell is a device that can convert light, or solar energy, into electrical energy. There are two types of solar radiation that cause a PV cell to produce energy: beam and diffuse radiation. Beam radiation is energy that travels directly from the sun to the solar collector. Diffuse radiation is the component that is scattered through the clouds and sky. Diffuse radiation makes it possible for a solar collector to produce energy even on overcast days. Typical solar radiation studies measure the two sources separately by using one collector aimed directly at the sun and a second that blocks the direct beam component and measures radiation from everywhere else in the sky. It is useful to know the two separate components because it allows one to calculate exactly how much energy can be produced as a function of the position of a solar collector.

A renewable energy study was conducted at Alcatraz Island by the National Renewable Energy Laboratory (NREL) from November 1995 to October 1996, collecting hourly solar radiation and wind speed measurements.²⁶ An entire year's worth of data are pieced together from this study, with the exception of data for the month of December. Preliminary calculations are performed using these data to determine the amount of energy that can be harnessed from the sun in San Francisco Bay. However, the solar measurements at Alcatraz Island were taken on horizontal and south facing vertical collectors, making it more difficult to calculate the solar energy available for a tilted solar module compared to when both the beam and diffuse components of solar flux are considered.

A second source of solar data is consulted in order to perform the energy calculations on a tilted collector. NREL has a Renewable Resource Data Center

(RReDC) that contains meteorological statistics for sites all over the US and in two US territories from the years 1961-2005.²⁷ This database does not contain solar measurements from Alcatraz Island, but it does have data taken at the San Francisco International Airport (SFO), located south of San Francisco on the mainland. Global radiation is solar radiation collected on a horizontal surface and includes both the beam component and diffuse radiation. The global radiation measured at Alcatraz Island was compared to that measured at SFO during the same months and year. The total monthly radiation received at each location can be seen in Figure 5 and Figure 6.

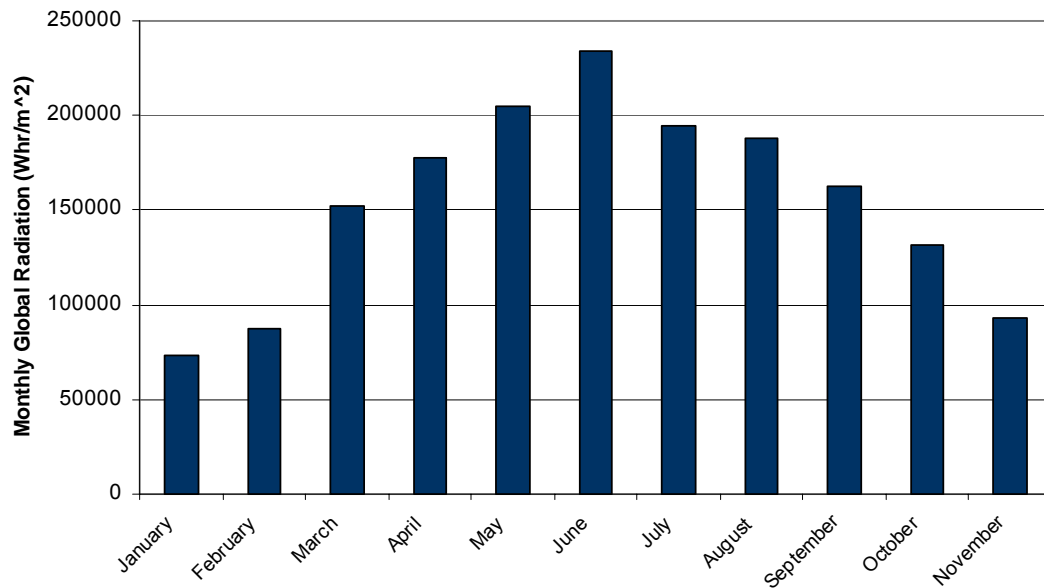

Figure 5: Monthly Solar Radiation Measured at Alcatraz Island in 1995-1996

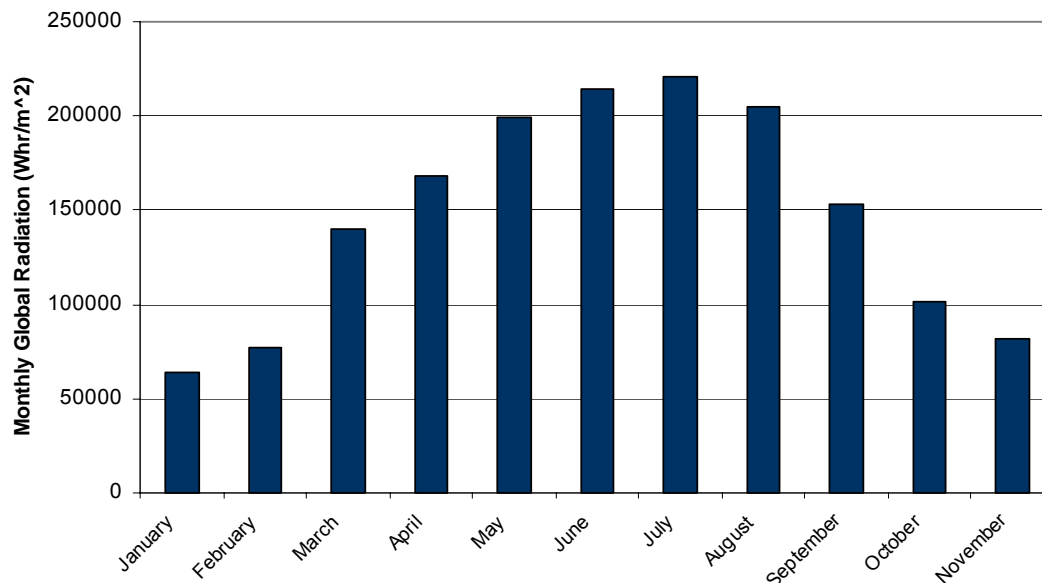

Figure 6: Monthly Solar Radiation Measured at SFO in 1995-1996

As seen in the figures above, the Alcatraz Island data compares favorably with the data measured at SFO with respect to quantity available and yearly profile. The only significant contradiction between the two sources is the total solar radiation measurement for the months of June and July. According to the data measured at Alcatraz Island, June is the sunniest month, whereas the SFO data indicates that July has the greatest solar exposure. There is a 12% difference between the two measurements for the month of July; however, this could be explained by the microclimates that occur in San Francisco. A microclimate is a local climatic effect as a result of the presence of bodies of water, hills or large amounts of concrete.²⁸ San Francisco has all three of these, causing its distinct weather system to be different than that of the surrounding area. The reduced solar radiation seen at Alcatraz Island in July and August, relative to SFO, is consistent with the microclimate of marine air drawn into the central San Francisco Bay by the thermal low over the hot central valley of California. This leads to fog, which might not be present at SFO.²⁹ For the entire 11 month period, there is only a 4.4% total difference between the two data sources,

indicating that the SFO data are similar enough to the Alcatraz data to be used to characterize the solar resource in the bay.

In addition to containing data for each hour, day and year, NREL has created a data set they call a typical meteorological year (TMY2) that combines data from the 30 year time span 1961-1990.³⁰ The solar flux, wind speed and temperature over this 30 year period are evaluated to find the most probable solar and weather condition for every hour, day and month of the year. This provides a more accurate representation of a renewable energy resource, rather than relying on a single year's worth of data that could have been an uncharacteristic period. The TMY2 data taken at SFO are used in all calculations to compute the solar energy availability at Alcatraz Island.

5.2 Solar Module Manufacturers

As alternative and renewable energy becomes more popular there are more available solar photovoltaic module manufacturers. Established solar panel manufacturers include Sharp, Sanyo, and SunPower, while companies like Suntech are relative newcomers to the industry. The two brands of solar modules used for this analysis are Sanyo and SunPower. SunPower is a US company that manufactures its modules in the Philippines. Sanyo is located in Japan; however, its unique silicon is manufactured in the US and its modules are assembled in Mexico. These companies were chosen because they produce some of the highest efficiency solar cells, and as roof space is a limiting factor in this project, panel efficiency is critical. The size, efficiency and cost information for each of these panels is used to characterize the solar electric resource at Alcatraz Island and calculate the economics of a solar energy system. It is of interest to note that the solar cell efficiency is always 2-3% greater than the actual solar module, and all efficiencies quoted are for the full module.

The SunPower module of interest is its 315 watt rated solar panel. This panel is chosen because it has the highest panel efficiency available on the market, 19.3%, and because of its aesthetically pleasing appearance.³¹ With high efficiency panels, fewer panels are needed, reducing racking system and installation costs. Also, less space is required, which is of high importance in this project. For a 100 kW system, only 320 of these panels are required. Although this panel is not currently available for purchase in the United States, it may be obtainable by the time this project is executed. If this is not the case; however, SunPower does have lower rated panels that have similar efficiencies but are slightly smaller in size. A price quote of \$7.00 per rated watt was obtained for an installed grid-tied SunPower system, including modules, power electronics and installation.³² This is a very reasonable price; however, it is not completely representative of a solar system cost for Alcatraz Island because it does not include the energy storage system cost that will be required for an off-grid system or any additional delivery and installation charges associated with the off-grid installation. Although the cost cannot be used for an installed system at Alcatraz, it suggests a price per watt for just the panels between \$4.00 and \$5.00.

Sanyo makes a solar cell from heterojunction with intrinsic thin layer (HIT) silicon, used in its HIP series solar modules. These panels use a combination of mono-crystalline silicon and thin film amorphous silicon, giving them an efficiency range of 15.3-17.3% and are available in power ratings of 180-205 watts.³³ Thin film silicon does not preserve its conductive quality as well as crystalline silicon, so the efficiency of these panels does tend to degrade over time, but they will still function at 14% efficiency at the end of their lifecycle. The Sanyo HIP-200 panels cost \$1,080 per panel or \$5.40 per rated watt but currently have a limited supply and can only be delivered in batches of 400 panels every four months.³⁴ The price quote obtained did not include a delivery cost. Since these panels are in short supply and difficult to obtain, it would be wise to reserve them far in advance if the NPS intends to go ahead with this option.

5.3 Solar Module Tilt Angles

The quantity of solar energy produced can be affected by the angle of tilt of the solar module relative to the horizontal surface. As mentioned previously, there are two types of radiation that trigger electrical generation by a solar module, but the angle of incidence between the beam radiation and the module has a significant effect on the amount of power the module will produce. The power output of a solar module is directly related to the amount of solar radiation it receives, and the more directly the sun strikes a solar panel, the more power it will produce. There are several factors that influence the angle between the direct beam radiation from the sun and a solar panel, including latitude of the module, time of year, time of day, angle between the panel and the ground and the angle between the front edge of the panel and true south.³⁵ Figure 7 below gives a visual representation of the following angles:

- θ_z = solar zenith angle, the angle between a vector normal to the horizontal surface of the earth and the direct beam radiation vector
- θ = solar incidence angle, the angle between a vector normal to the surface of a solar collector and the direct beam radiation vector
- β = tilt angle, the angle between a solar collector and the horizontal surface of the earth
- γ = solar azimuth angle, the angle between a vector normal to the surface of a collector projected on the ground and a vector facing true south

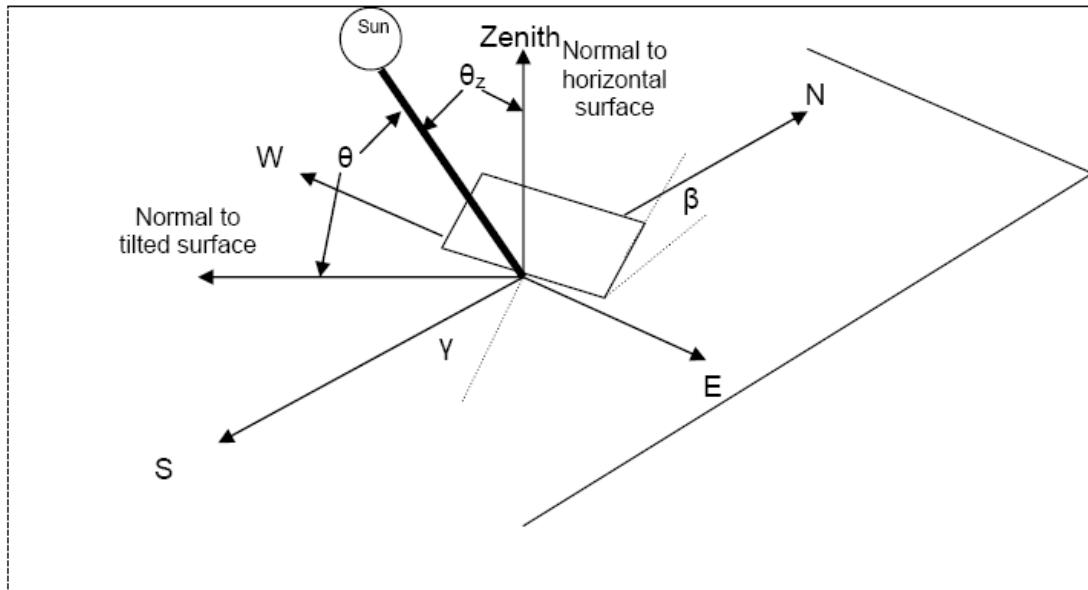

Figure 7: Diagram of the Solar Angles: θ_z , θ , β and γ ³⁶

The remaining angles not represented on Figure 7 are:

- Φ = latitude at the location of a solar collector
- δ = solar declination angle, the angle of the earth's axis of rotation with respect to the location of the sun (varies between 23.5°N during the summer solstice and -23.5°S at the winter solstice)
- ω = hour angle, the angle between the longitudinal position of a solar collector and the longitude where solar noon is occurring on the earth. Solar noon is defined as the average time between sunrise and sunset and has an hour angle of 0° . The hour angle decreases at 15° per hour traveling east and increases at 15° per hour to the west.³⁷

Ideally, a solar module would face directly normal to the beam component of the solar radiation at all times to maximize energy production. This is done by adjusting the tilt angle, β , of a module, allowing it to be set relative to the solar declination angle, and the solar azimuth angle γ , which accounts for the hour angle fluctuation. However, the solar declination of the earth changes every day

and the hour angle shifts constantly through the day, which means that the tilt angle would have to be adjusted daily and the solar azimuth angle adjusted at least hourly. There are solar installations with the ability to track the location of the sun and adjust automatically, but this increases the complexity of the system and the cost. It is common practice to set the solar azimuth angle at 0° so that the module is always facing true south. This is this optimal position, because it takes advantage of both the morning and afternoon solar availability. The change in solar declination each day is very minimal, so it is not necessary to adjust the tilt angle every day. An alternative is to optimize the solar modules for each month; however, for a large installation, it can still be laborious to adjust every module each month. The preferred method for a large, manual installation is to set the tilt of the solar modules at an angle so that the solar electric energy production is optimized for the entire year.

As Alcatraz Island is located at latitude 37.37°N of the equator, the sun will always be located to the south of it; however, the optimal monthly tilt angle of the panels shifts between 5° in July and 60° in January. It is not sensible to optimize the solar modules for the extremes of either summer or winter, the best option being to design for the fall and spring when the sun is at the same location in the sky relative to the modules. Solar calculations were performed with the NREL data from SFO, proving the optimal tilt angle of a solar module located on Alcatraz Island to be 28° off of the horizontal and facing true south. The analysis shows that a module tilted at this angle can produce 9.3% more energy over the entire year than a horizontal panel. Solar panel mounting systems come with preset angles, fortunately 30° is a common angle setting and very close to the desired 28° angle.

There are certain disadvantages associated with installing the solar modules tilted up at an angle. The racking system for a tilted panel installation is more complicated and more expensive to purchase than the installation kit for

horizontal mountings. Also, more space is required for a titled system so that each row of panels does not cast a shadow on the row behind it. In order to prevent a 28° tilted solar module from shading any subsequent panels, the distance between the front edges of the panels has to be 1.24 times the height of the panel in the spring and fall. This dimension increases to 1.72 times the height of the panel in the winter and is almost negligible in the summer. A visual representation of the module tilt angle relative to the solar declination angle of the sun is available in Figure 8.

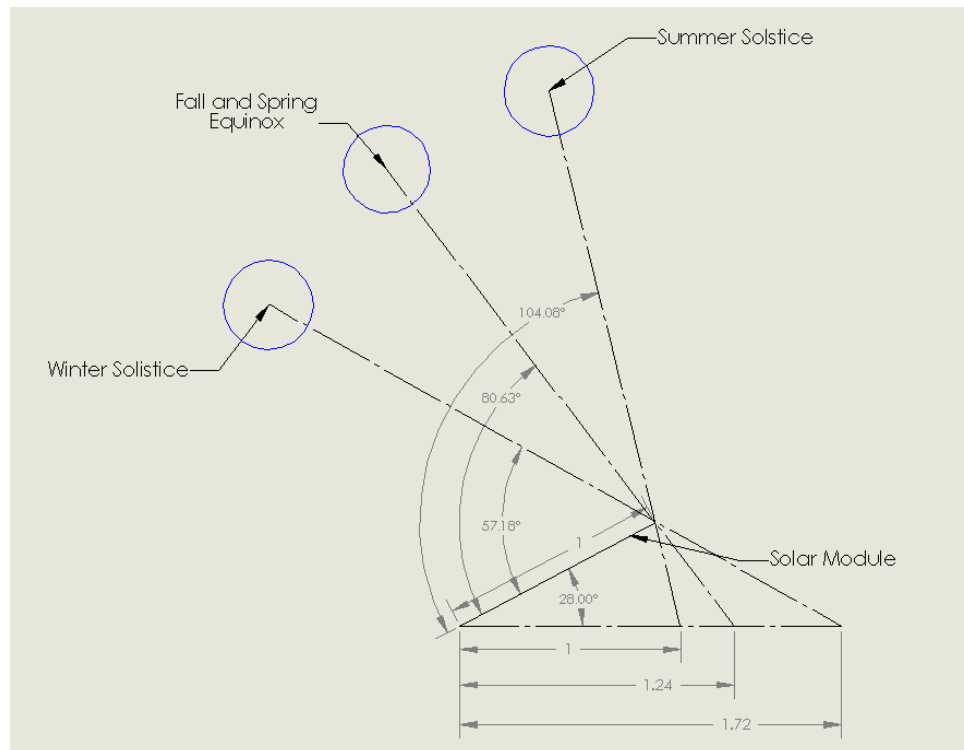

Figure 8: Required Space Between 28° Tilted Panels in Summer, Winter, Spring and Fall

Another issue concerning tilted panels is the east-west solar azimuth orientation of the panels. The buildings being considered for a solar installation on Alcatraz are the Cell House and New Industries Building, neither of which is oriented north-south. The long wall of the Cell House is facing 45° west of true south and the short wall of the New Industries building is facing 30° east of true south. This

is not a concern if the panels are laid horizontal, but if they are tilted, the modules should be facing exactly south. Fewer panels can be installed on a building if they are not aligned with the walls of the building, which can be observed in the figures below for the Cell House.

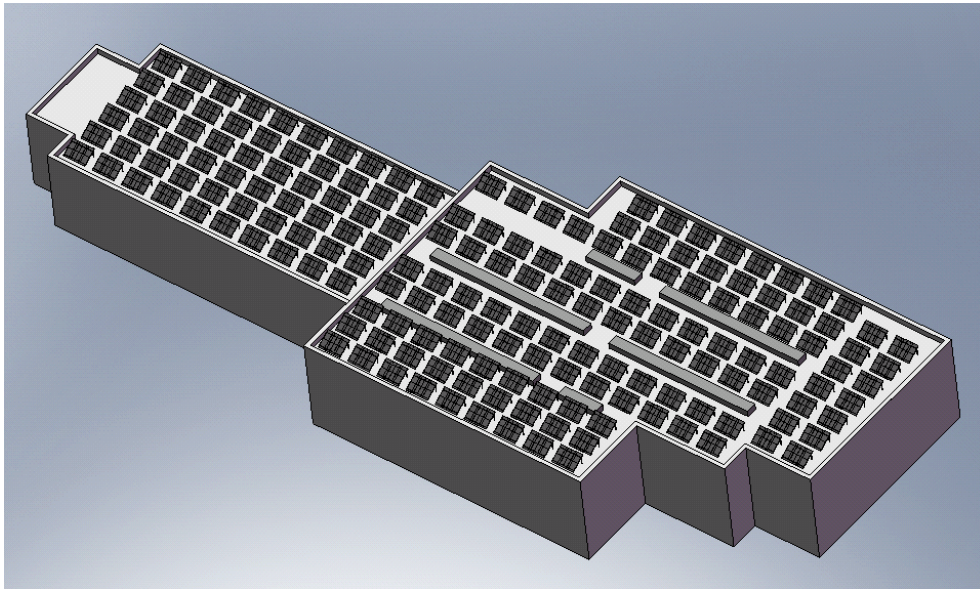

Figure 9: Solar modules aligned with the Cell House long wall.

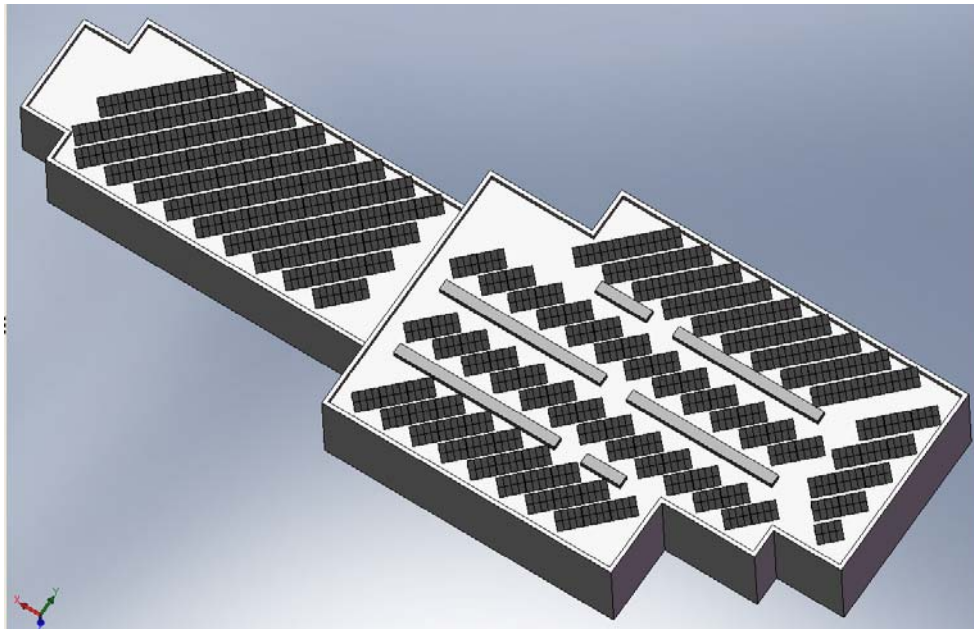

Figure 10: Solar modules oriented true south on the Cell House

As seen in Figure 9, a solar array arranged in line with the walls of the building results in an orderly, cleaner looking system that can accommodate more panels. However, the south facing array can produce more total energy for the year. The energy production loss as a result of orienting the modules off of true south is explored in the following section.

5.4 Solar Power Availability

The amount of power that can be harnessed from a solar PV system is dependent upon the amount of solar radiation available, the efficiency of the solar modules and the amount of space available. The rated power of a PV system simply refers to the amount of power that it can produce in full irradiance, which is defined as 1000 W/m^2 . Two systems can have the same rated power but will require a different number of modules based on the size of the panel and its efficiency. If an installation is not limited by space, it can be more economical to use more, lower efficiency panels. This project, however, is limited by space and high efficiency solar modules are used for all of the calculations.

In order to determine the solar power availability at Alcatraz Island and the advantage of tilting the modules, a 100 kW rated system is considered first. This number is chosen because it is close to the average 98 kW load and will easily fit on the roof of either building using various solar modules. The TMY2 data from NREL is used for all of the calculations. The information required to determine solar electricity production is solar radiation, ambient temperature, wind speed, panel efficiency and total area. Solar panel efficiency is defined for a certain panel temperature, observing decreased efficiency at higher temperatures and increased efficiency at lower temperatures, while the panel temperature is a function of the solar irradiation on the panel, the ambient temperature and the wind speed, which provides convective cooling. Power output is also dependent

upon the solar incidence angle between the beam radiation and solar module, so it varies based on the time of day, time of year and the panel orientation. A detailed description of the analysis can be seen in Appendix C, while the results are discussed below.

The sun does not supply constant, rated irradiation, but rather varies through the day as seen in the Figure 11 below. As a result of this, solar modules do not produce at their rated power during all of the daylight hours. Since rated irradiance is 1000 W/m^2 , on a characteristic day in San Francisco in July, a horizontal solar panel will produce close to its rated power for three hours and taper off in the morning and evening. One way to estimate the daily energy output of a solar system is to calculate the number of peak (1000 W/m^2) hours of sunlight and multiply it by the system rating. The peak sunlight hours are found by summing the total solar irradiation for the day and dividing by $1,000 \text{ W/m}^2$. There are 7.26 peak hours of sunlight in San Francisco per day in July, followed by no useful solar irradiation for the remainder of the day. Thus, 100 kW rated system will produce 726 kWh of electrical energy per day on average. This is roughly $\frac{1}{3}$ of the total daily energy consumption at Alcatraz Island, so a solar system would have to be built three times this size to be able to supply the total energy demand for July.

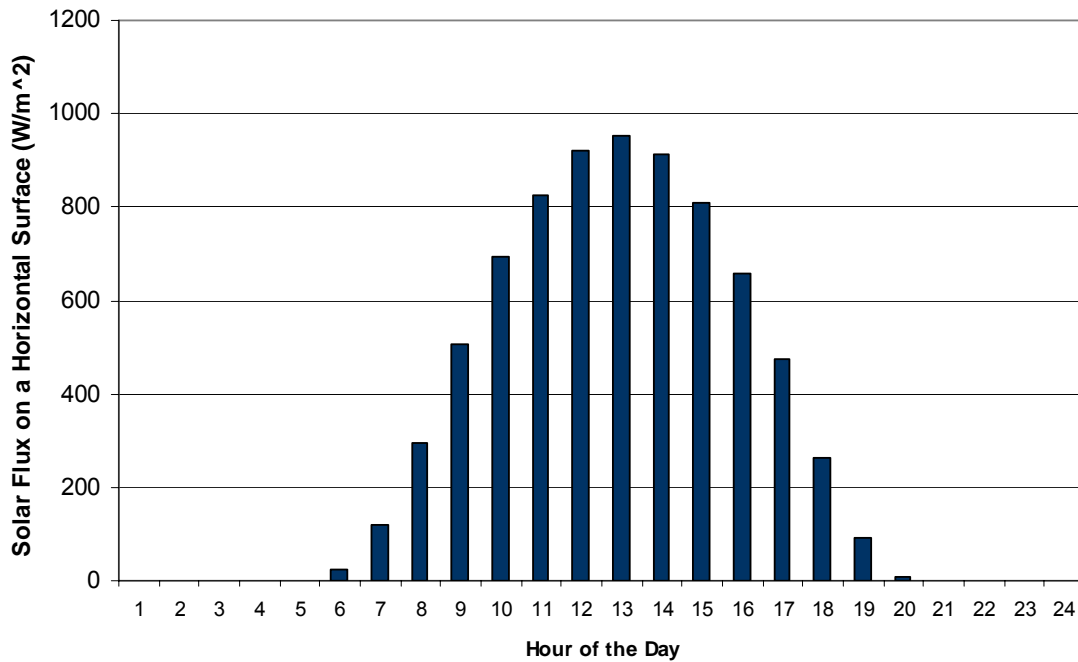

Figure 11: Average Hourly Solar Radiation for SFO in July

There is also a significant variation in solar radiation at SFO based on the time of year, as seen in Figure 12. July sees the greatest amount of solar irradiation, observing four times more solar flux than December. In contrast to July, December only has 2.2 peak hours of sunlight on a horizontal surface each day, so a solar system would have to be rated at 1090 kW to produce all of the energy required in December. This would be a very large, expensive system and would not fit on the roof of either building, leading to the decision to design the system only large enough to supply the full energy demand for the month of July.

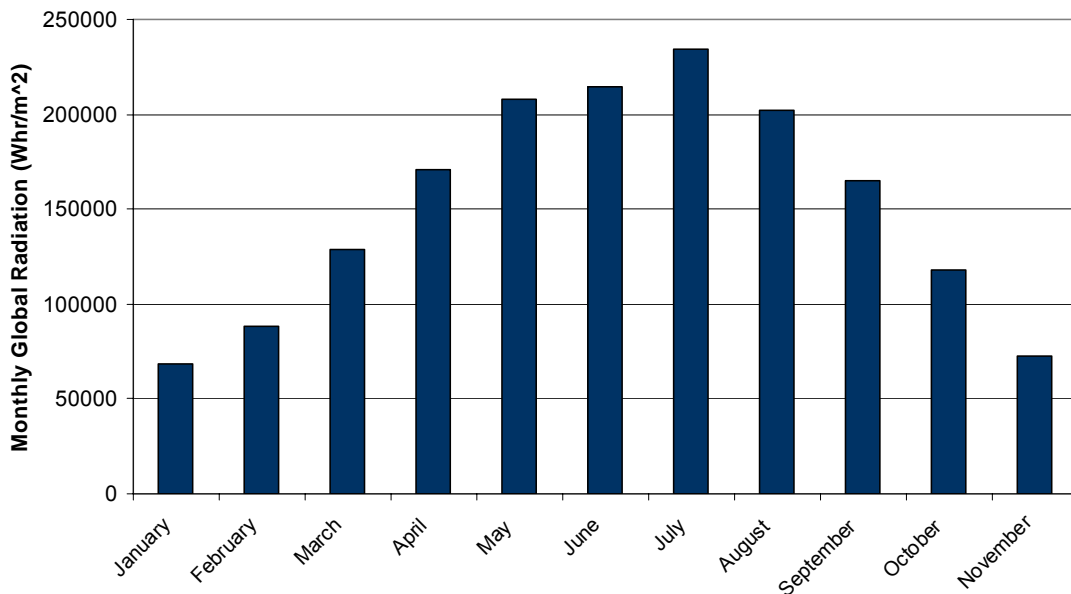

Figure 12: Average Monthly Solar Radiation at SFO

After the daily and seasonal effects are determined, the different panel tilt configurations are compared. For the analysis, properties of the Sanyo HIT 200 kW rated panels are used. A 100 kW rated flat panel configuration is assessed first and compared to the monthly energy demand at Alcatraz Island. For the energy demand calculation, the average power consumption of 98 kW is multiplied by the number of hours in each month. This system can produce up to 19.28% of the yearly power requirement at Alcatraz Island. This provides as much as 30.4% of the energy requirement in July, but only 8.2% of the demand in December. A visual representation of the monthly energy production for this system can be seen in Figure 13.

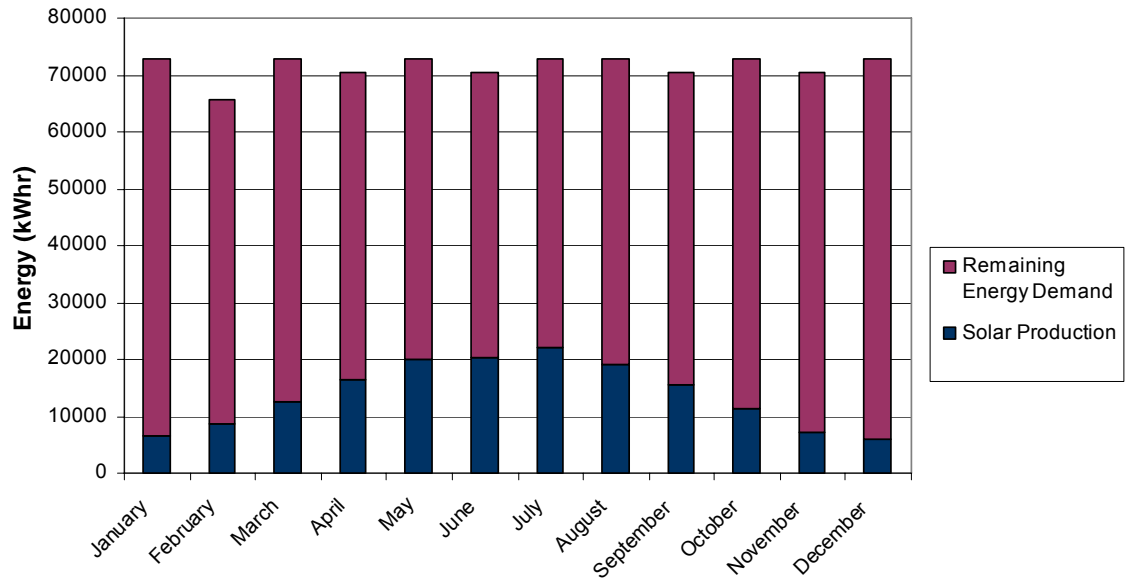

Figure 13: Monthly Solar Energy for a 100 kW Rated Horizontal Panel Solar System

Next, the effect of tilting the solar modules at an angle of 28° is examined and the results can be seen in Figure 14. By tilting the panels, the solar energy production decreases in the summer but increases for the remaining seasons. This is due to the fact that the optimal tilt angle for a solar module in San Francisco in the summer is 5° , so a horizontal panel orientation is closer to ideal than 28° . The result of tilting the panels 28° off of the horizontal and facing them true south is a net increase of 9.3% in energy production over the year compared to a horizontal panel layout, providing 21.08% of the total demand.

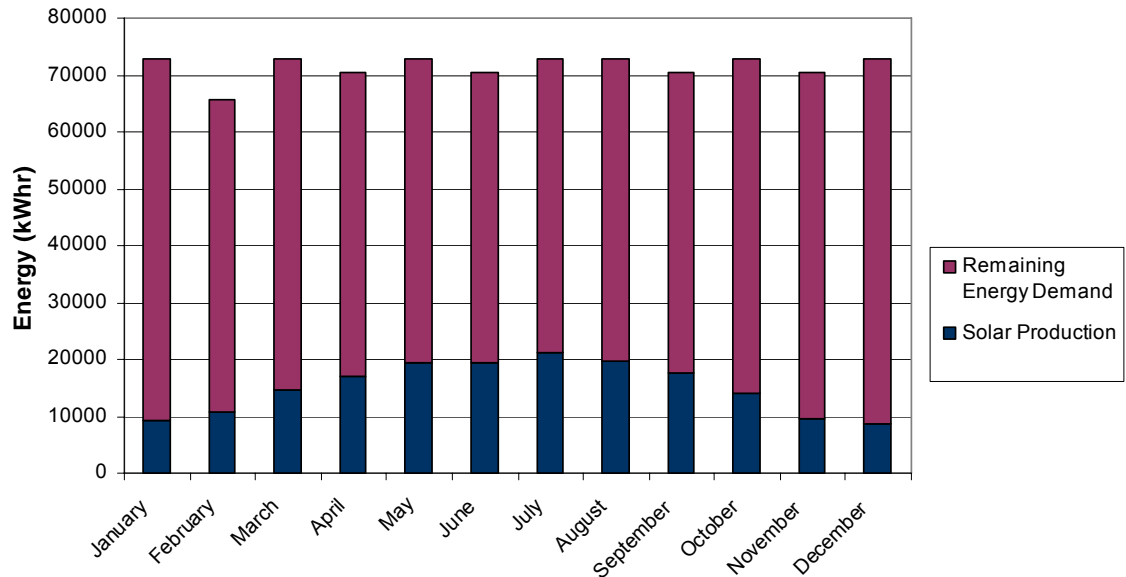

Figure 14: Monthly Solar Energy for a 100 kW Rated Solar System Tilted at 28°

As mentioned previously, neither of the buildings of interest are oriented to the south; therefore, the energy production loss caused by installing the solar modules in line with the buildings is calculated. The monthly energy output of each system is shown in Figure 15 and Figure 16. The New Industries building is facing 30° east of true south, so an analysis is performed to determine the power decrease caused by aiming the panels in this direction. The yearly energy output of tilted panels facing 30° east of south is 5.3% greater than that for flat panels but 3.6% less than for tilted, south facing panels. This is a net yearly production of 20.32% of the energy demand. Next, the effect of facing a solar system at 45° west of south, or aligned with the roof of the Cell House, is calculated. The result of this is a 6.3% increase in yearly power output compared to flat panels and a 2.7% decrease in energy production versus tilted, south facing panels, providing a total of 20.49% of yearly of the demand.

It is counterintuitive that a solar module facing 45° off of south would produce more energy than one at 30° off of true south since it is facing farther away from

the optimal orientation. An examination of Figure 11, the average hourly solar radiation throughout the day, explains this. During the month of July, solar noon occurs at 12:45. Until this hour, the sun is in the eastern part of the sky relative to San Francisco, and after this time the sun is to the west. The amount of solar flux received on a flat collector for the first half of the day is 3392.6 Wh/m², while the amount received during the second half of the day is 4171.1 Wh/m². The majority of the solar flux occurs after solar noon, so there must be more solar radiation available in the afternoon, from the west side of the sky. Therefore, a panel facing west will observe more solar flux during the day and produce more energy.

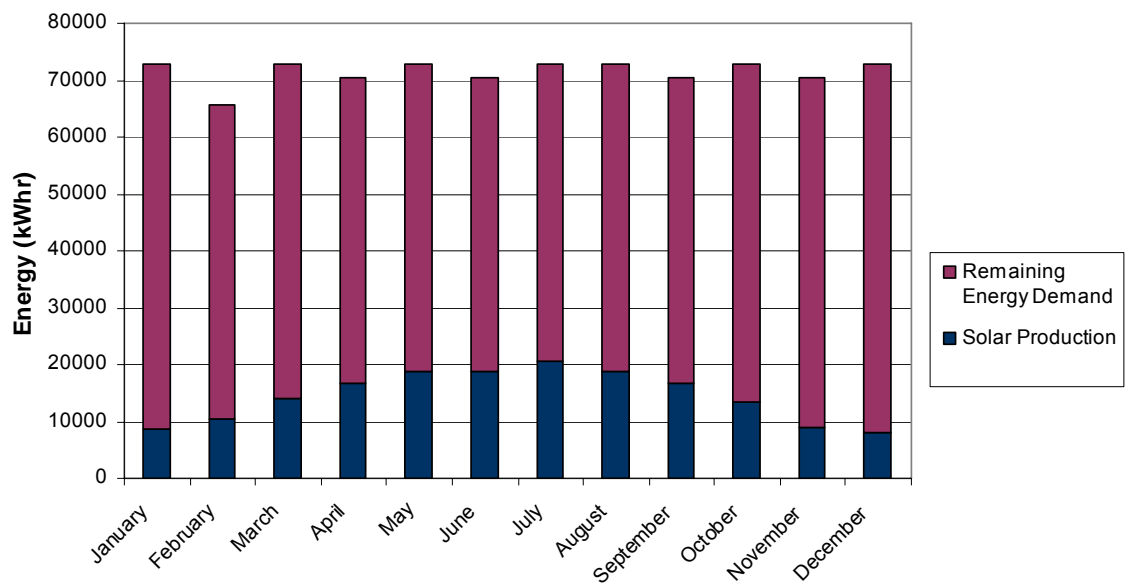

Figure 15: Monthly Solar Energy for a 100 kW Rated Solar System Tilted at 28° Oriented At 30° East of True South

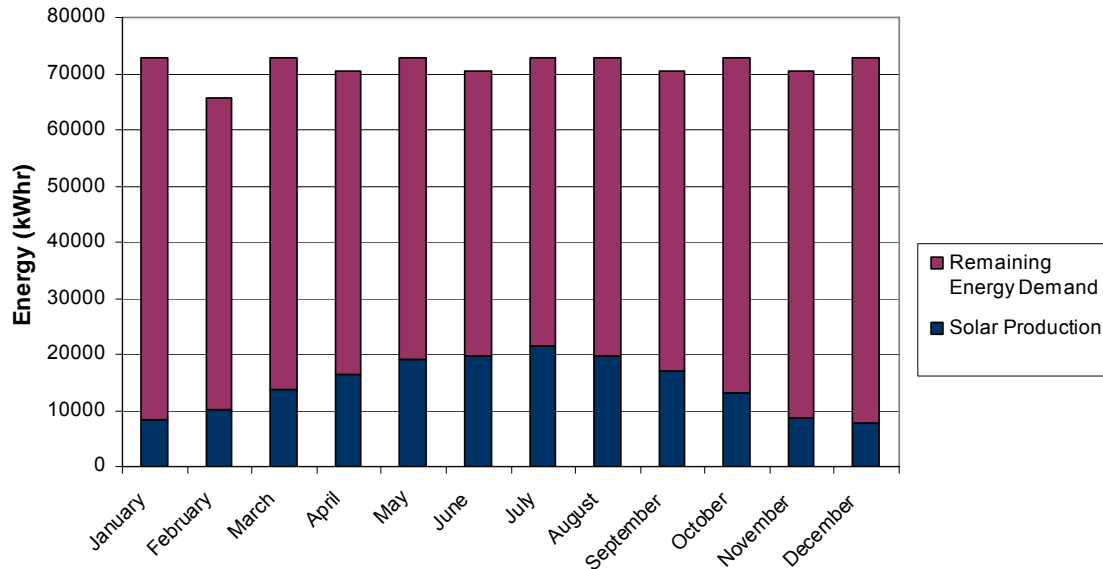

Figure 16: Monthly Solar Energy for a 100 kW Rated Solar System Titled at 28° Oriented at 45° West of True South

A side by side comparison of the energy output of the four different arrangements can be seen in Figure 17. This shows the monthly energy production of each design relative to the others. Not surprisingly, a horizontal panel system produces the most energy in the summer months, and a south facing, tilted system produces the most in the winter. Unexpectedly, there is slightly more energy available in the summer months from the south-west facing tilted panels compared to the south facing tilted panels. As explained above, there is more solar flux available in the west side of the sky than the east, so a west facing panel optimizes the resource. In spite of the greater solar flux in the west side of the sky, the south-east facing, tilted solar module produces more energy during the winter than the south-west directed module. This is because the sun is so low on the horizon in the winter that a panel with the most southern exposure will receive more flux and produce more energy.

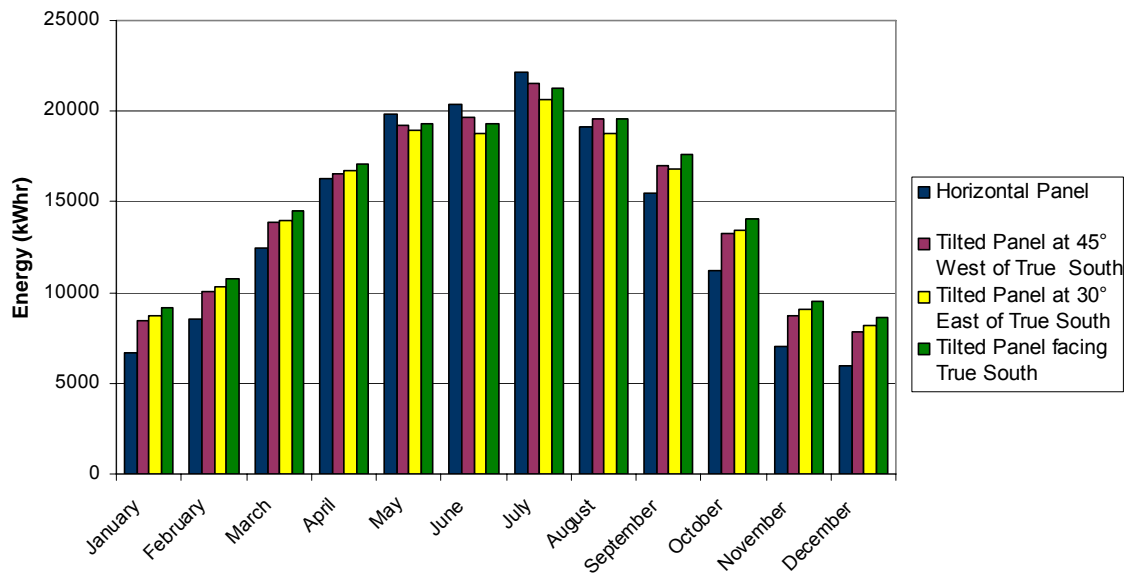

Figure 17: Comparison Between Flat and Tilted Panels at Different Orientations

The last item to verify is the optimal size of a solar system in San Francisco Bay for the month of July. It is determined, using the number of peak sunlight hours, that the optimal rating for a solar system in the San Francisco Bay in July is 330 kW. This is verified with the TMY2 data by conducting the analysis with a 330 kW rated system and calculating the monthly power production. The results, shown in Figure 18, verify that a horizontal, 330 kW rated system can produce 100% of the energy required for Alcatraz Island in July, 27.12% of the energy required in December and 63.6% of the energy need for the entire year.

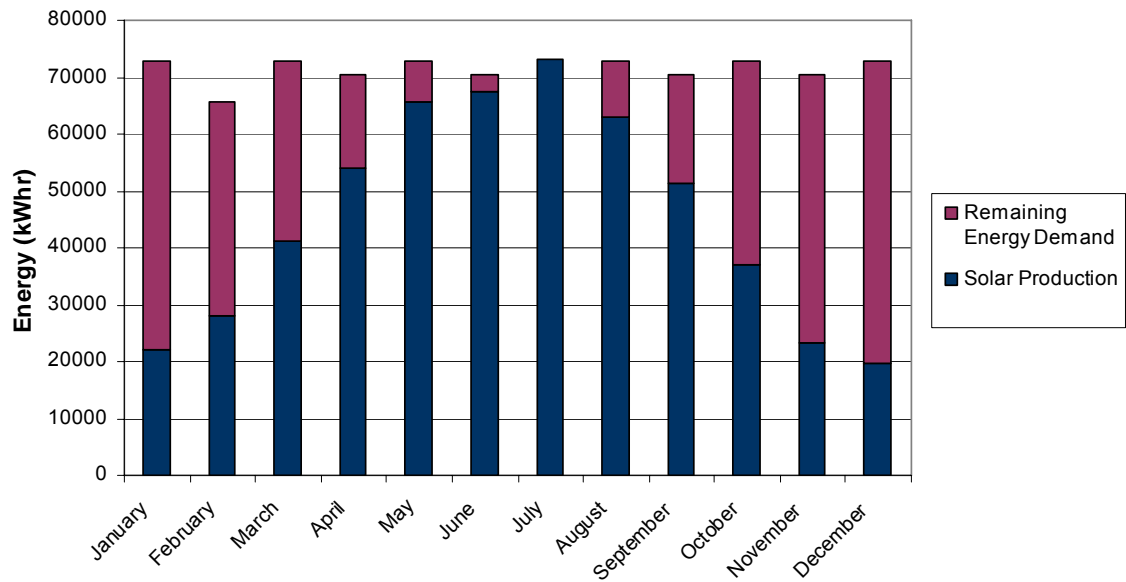

Figure 18: Monthly Solar Energy for a 330 kW Rated Horizontal Panel Solar System

Tilting this same sized system up at 28° increases the yearly energy production to 69.58% and the December production up to 39.08% but reduces the summer production to 96.28% of the monthly demand for July. The monthly energy production of a 330 kW, tilted solar system is represented in Figure 19 below. In order for a tilted solar system to produce all of the energy demand for Alcatraz Island in July, it would have to be rated at 345 kW, producing a total of 72.75% of the yearly energy demand on the island.

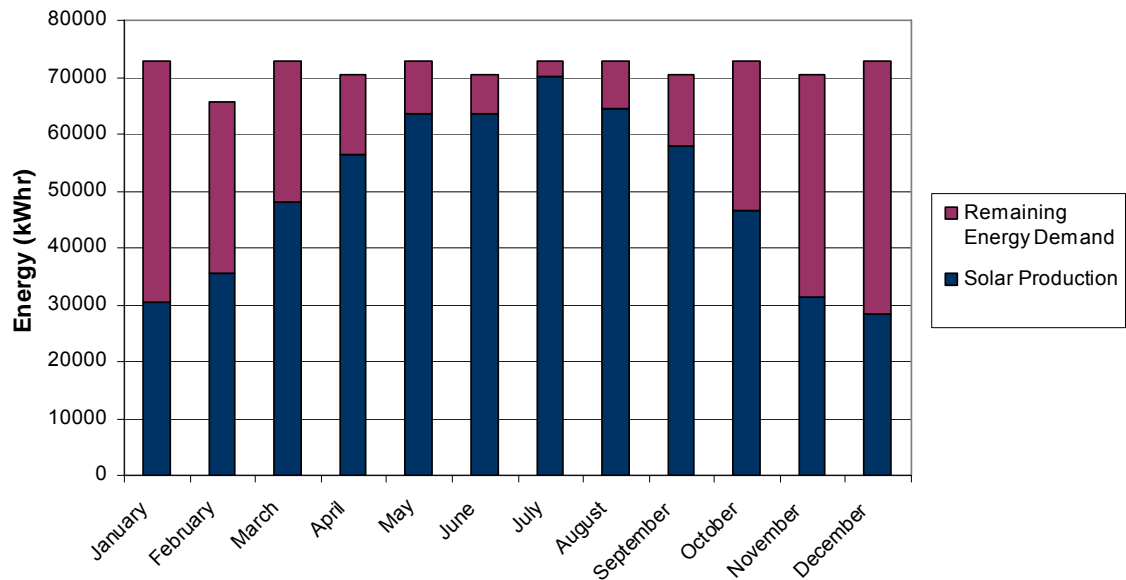

Figure 19: Monthly Solar Energy for a 330 kW Rated South Facing Solar System Tilted at 28°

Unfortunately, a 330 kW rated system cannot fit on the roof of the New Industries Building, so it would have to be divided between the two buildings or be installed entirely on the roof of the Cell House. Space will become an even greater issue if the panels are installed at an angle. Although a south-facing, tilted panel arrangement can produce the most energy for the year, this additional energy may not be worth the added inconvenience and expense of arranging the panels in this manner. A titled system that is facing 45° west of south only produces 2.7% less energy yearly than its south-facing counterpart and will be easier to install and accommodate more panels on the Cell House. By facing the panels at 30° east of south on the New Industries building, there is an energy loss of 3.6% for the year versus the south-facing panels. A horizontal panel installation will produce the least amount of energy per year at 9.3% less than true south facing, tilted panels and 6.3% less than the south-west facing, tilted panels; however, it will be the easiest and cheapest system to implement. All of these possibilities are discussed in greater detail in Chapter 10.

6 Wind Energy Assessment

6.1 Wind Resource

An examination of the wind energy resource at Alcatraz Island is conducted next. Wind data collected during the 1995-1996 NREL study at Alcatraz Island is evaluated first. An anemometer mounted on a 10 ft mast on the exhaust chimney of the Cell House took hourly records of the wind speed and direction. Wind turbines are generally installed at no less than a height of 10 meters, so before the average daily and monthly wind speed values could be calculated, the wind data had to be scaled from 10 feet to 10 meters. This is because of the boundary layer that exists over a surface. As wind passes over the ground or buildings, it is slowed due to friction. This effect has an inverse relationship to height, which is why the minimum recommended height for a wind turbine is 10 meters.³⁸ The boundary layer is represented by the curve in Figure 20 and shows how wind speed is affected by interaction with the ground. The horizontal scale shows the percentage of “unimpeded wind” versus the height above the ground over different surfaces.

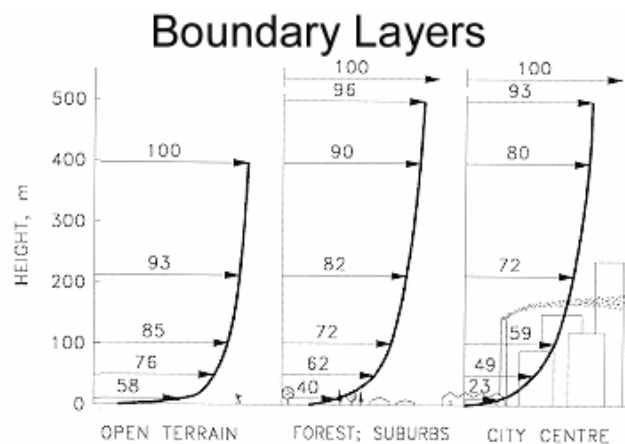

Figure 20: Examples of the Boundary Layer of Wind over Different Terrain³⁹

The hourly wind speed data at Alcatraz Island, obtained from NREL, was converted into the daily average wind speed over the period of the study. Although the hourly wind speed at Alcatraz Island can reach 18 m/s, the average daily wind speed never gets higher than 10 m/s, and the yearly average is only 3.4 m/s. Figure 21 shows the average wind speed for each day from January 1st to late November. Peak average wind speed is found in the winter and early spring, although the late spring and summer period has the most consistent wind.

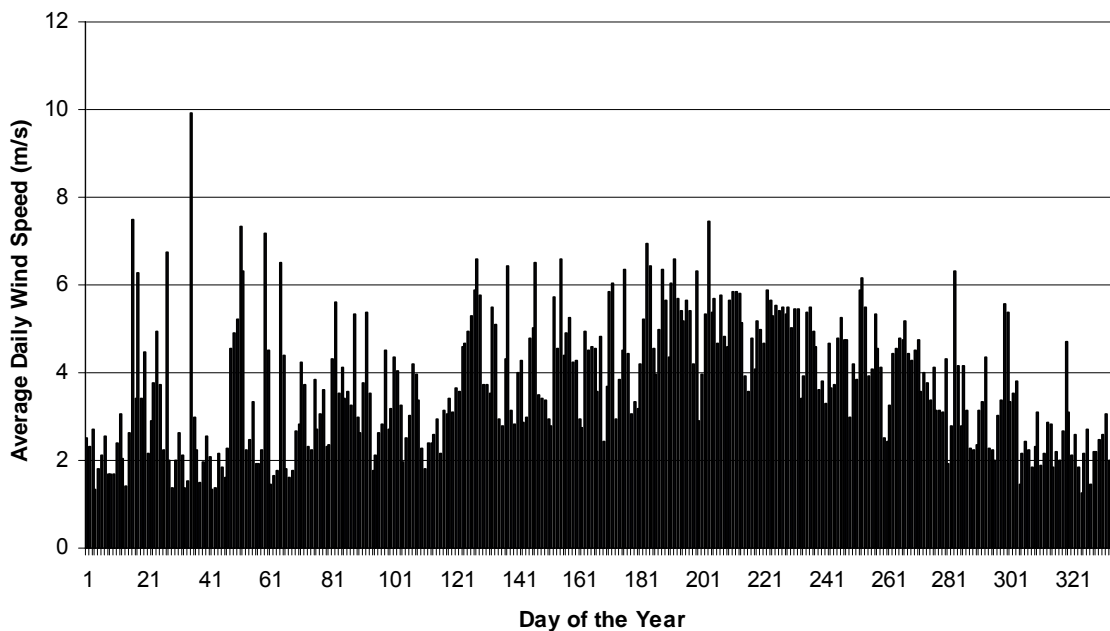

Figure 21: Average Daily Wind Speed at Alcatraz Island

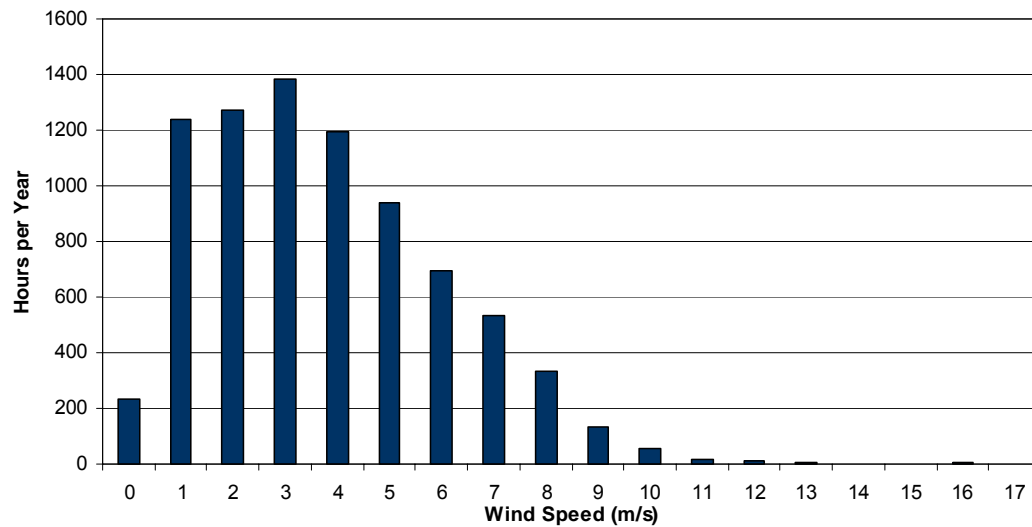

Figure 22: Alcatraz Island Wind Speed Distribution

A wind speed distribution is created to show the number of hours per year that Alcatraz receives wind at each speed, which can be seen in Figure 22. This is a standard method of characterizing the wind energy availability of a site. The graph in Figure 22 indicates that the most probable wind speed at Alcatraz Island is only 3 m/s. All of the small wind turbines considered for this project have cut-in speeds between 2-3 m/s; which is the minimum wind velocity for a turbine to produce power, meaning that for the majority of the time the wind is blowing, these turbines will be producing near their minimum amount of power. The rule of thumb for a wind energy installation is that the site should have a most probable wind speed of at least 5 m/s, leaving Alcatraz Island out as an option for wind turbines based on the NREL data.

There is the possibility that the Alcatraz wind data is not representative of the actual condition. Alcatraz Island is in the middle of the San Francisco Bay, which appears windy; however, the data were measured more than ten years ago and over a single year time period with uncertain anemometer placement and airflow conditions on the roof of the Cell House. For these reasons, the Alcatraz data

was discarded in favor of the NREL data taken at the San Francisco Airport (SFO). In order to confirm the wind resource at Alcatraz Island, it will be necessary to install another, taller anemometer on the roof of the Cell House and record several months worth of wind data to compare with the data taken previously. If a second study obtains similar results to the 1995-1996 Alcatraz data, then it is likely that a sufficient wind resource is not present on the Cell House roof. The location of the anemometer could be a cause of the slow wind speed. The Cell House is the tallest building on the island and is located at the highest point. As the wind rises to flow over the island, it may get caught on the front edge of the Cell House, causing a turbulent recirculation zone over the roof of the Cell House, which is not suitable for wind energy turbine placement.

The data measured at SFO airport by NREL are utilized for the wind analysis. The average daily wind speed and wind speed distribution graphs can be seen in Figure 23 and Figure 24 below. This wind data were measured at a height of ten meters, so they did not need to be scaled to get out of the boundary layer as with the Alcatraz data. According to the wind data measured at SFO, the average wind speed in San Francisco is 4.6 m/s and the most probable wind speed is 5 m/s. Although this is still on the low side for a wind turbine installation, it is within an acceptable range.

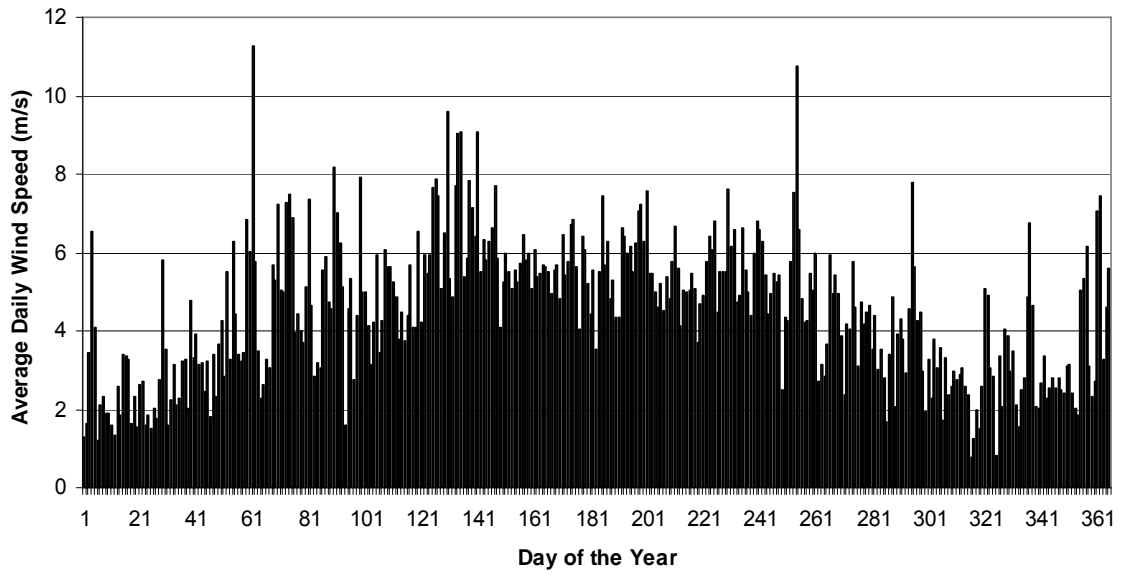

Figure 23: TMY2 Average Daily Wind Speed at San Francisco Airport

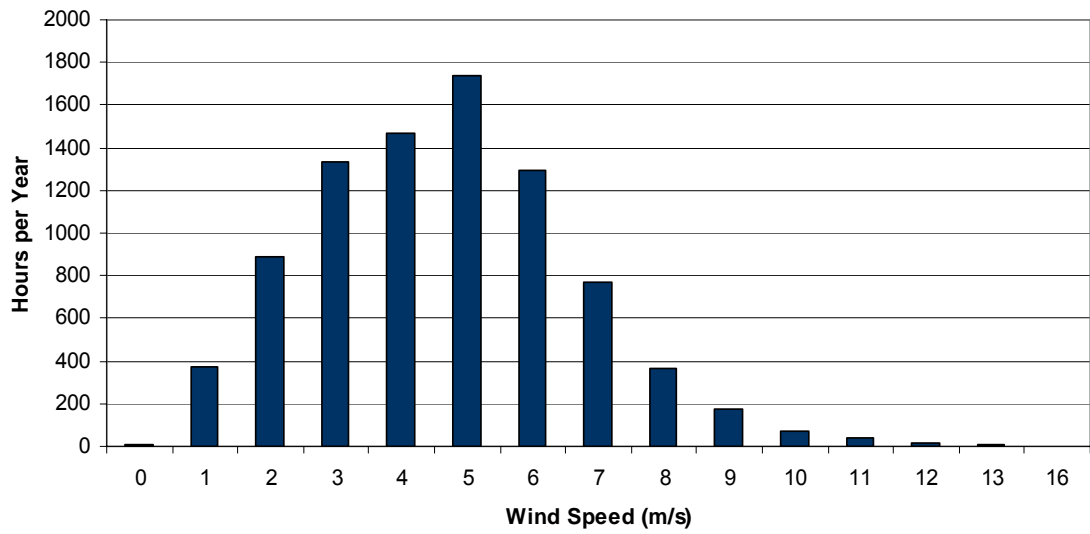

Figure 24: SFO Average Wind Speed Distribution from 1995-2005

6.2 Wind Turbine Manufacturers

The National Park Service requested that the University of Washington consider small wind turbines for the roof of the Cell House. These are smaller turbines with a lower rated wattage and lower wind speed requirement than the large turbines seen at wind farms. The small wind turbines considered include the horizontal axis turbines made by Bergey, Abundant Renewable Energy (ARE) and Swift and the vertical axis turbines manufactured by PacWind and Windside. All turbines are assumed to be located on the roof of the Cell House, as that is the highest point on the island and presumably has the greatest wind due to the lack of obstructions. However, the Cell House could be experiencing turbulent wind flow and flow separation over it and there may be a site more suitable for wind turbines.



Figure 25: Swift Rooftop Wind Turbines ⁴⁰

Swift wind turbines, seen in Figure 25, are designed specifically for rooftop installations and do not sit very high above the building, which is consistent with the NPS desire for placing wind turbines on the Cell House roof. These turbines have a cut in speed of 2.3 m/s and are rated at 1.5 kW in wind of 12.5 m/s.⁴¹ Although the average wind speed in San Francisco is above the cut-in speed of the Swift turbine it is far below its rated speed; therefore, the turbine would only be producing a fraction of the rated wattage for the majority of the time. Another factor to be considered on a roof-top wind turbine installation is the boundary

layer of wind over a surface. As mentioned previously, wind blows slower at heights near to the ground or surface. This is why rooftop wind turbines are not generally recommended and why wind turbines are positioned ten meters higher than the tallest obstacle in the area. The wind data at SFO were measured at a height of ten meters, so they would have to be scaled down to account for the wind boundary layer over the Cell House building, reducing the average wind speed experienced by the turbine.

The two other horizontal axis turbines, ARE and Bergey have similar style and wind requirements. ARE makes two small wind models: a 2.5 kW rated turbine and a 10 kW rated turbine. Both turbines are rated for 11 m/s wind and have a cut in speed of 2.5 m/s. The only difference between the two turbines is the length of their blades, which dictates the rated power, as power is a function of the swept area of the turbine. The 2.5 kW turbine has a blade diameter of 3 m and the 10 kW rated turbine has a diameter of 7.2 m. This is an important distinction, because it will dictate how high the turbine has to be mounted and how noticeable it will be from the rest of the island or from shore.⁴² The 2.5 kW rated ARE turbine is shown in Figure 26 below. The ARE Wind Turbines can be used in either a grid-connected system or in an off-grid battery charging system. The system cost for each turbine and configuration is seen in Table 4.



Figure 26: ARE 110 Wind Turbine⁴³

Table 4: ARE Systems and Costs⁴⁴

Turbine	Rated Power (kW)	System Configuration	Equipment Included	Cost (\$)
ARE 110	2.5	Grid Connection	Turbine and Inverter	11,800.00
		Off-Grid Battery Charging	Turbine and Charge Controller	12,650.00
ARE 442	10	Grid Connection	Turbine and Inverter	39,950.00
		Off-Grid Battery Charging	Turbine and Charge Controller	39,600.00

Bergey manufactures three different models that were considered for this project. Its turbines come in power ratings of 1 kW for the BWC XL.1, 1.5 kW for the BWC 1500, and 7.5 kW for BWC Excel; however, the 1.5 kW turbine has been discontinued, so it will be excluded from this report. The cut-in and rated wind speeds are 2.5 m/s and 11 m/s for the XL.1, and 3.1 m/s and 13.8 m/s for the Excel. Again, the turbine with the greater power rating has a larger blade diameter of 6.7 meters, versus 2.5 meters for the lower rated turbine.⁴⁵ While the Bergey XL.1 is intended for mainly off-grid applications, the Excel is available for either a grid-connected system or for off-grid battery charging. Both turbines can be seen in Figure 27, with their relative cost information given in Table 5.

Figure 27: Bergey Windpower Turbines (left: 1 kW, right: 7.5 kW)⁴⁶

Table 5: Bergey Systems and Cost Breakdown⁴⁷

Turbine	Rated Power (kW)	System Configuration	Equipment Included	Turbine (\$)	Tower (\$)	Inverter (\$)	Total Cost (\$)
BWC XL.1	1	Off-Grid Battery Charging	Charge Controller	2,590	1,595-2,450	2,165-3,495	6,350-8,535
BWC Excel	7.5	Off-Grid Battery Charging	Charge Controller	21,900-22,900	7,400-13,400	3,495-3,995	32,795-40,295
		Grid Connected	Inverter	27,900	7,400-13,400	N/A	35,300-41,300

The remaining wind turbines are the vertical axis turbines produced by PacWind and Windside. Windside is a turbine manufacturer from Finland that produces wind turbines, as seen in Figure 28. The Windside turbine of particular interest is a 2.4 kW rated turbine at a speed of 15 m/s with a cut-in speed of 1.5 m/s.⁴⁸ Compared to the Bergey and ARE turbines, the WS-4C is able to start producing power at lower wind speeds due to its lower cut-in speed. This will be beneficial for the high number of low wind speed days; however, it is not going to run at its rated capacity as often because of its higher rated speed condition. Unfortunately, it was not possible to contact a distributor for Windside turbines in the US, so the cost of these turbines is unknown.

Figure 28: Windside WS-C4 Turbine⁴⁹

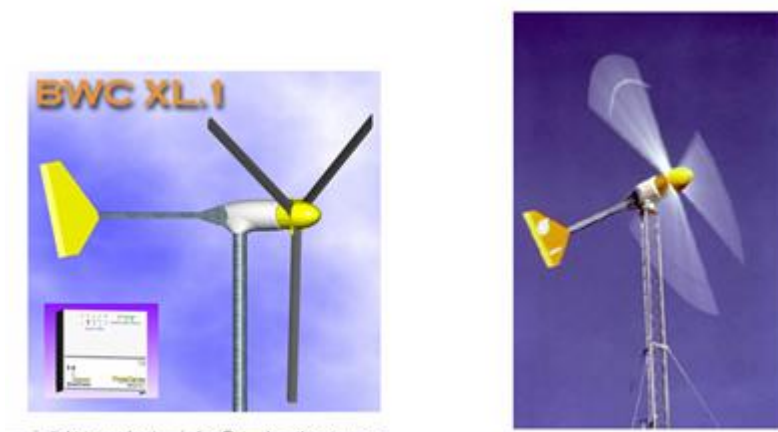
PacWind is a California based wind turbine manufacturer that is committed to making renewable energy opportunities available to the public. There were three PacWind turbines considered for this project. The first one is called the SeaHawk and has a rated wattage of 500 W at 12.5 m/s and a cut in speed of 3.13 m/s. This is their smallest turbine in size and power and has the least conspicuous design. The other two PacWind turbines are the Delta I and Delta II. The Delta I and II look similar, but the Delta II has a turbine diameter of 4.0 m and height of 3.0 m, while the Delta I is only 1.2 m wide by 0.8 m tall. Both turbines have the same rated speed of 12.5 m/s, but the Delta I has a rated wattage of 2.0 kW and the Delta II is rated at 10.0 kW. The most unusual thing about these two turbines is that the Delta II has a lower cut-in speed than its smaller version with a value of 2.2 m/s versus 3.6 m/s for the Delta I.⁵⁰ With the wind speed in San Francisco as low as it is, it is beneficial to be able to produce power at low wind speed. A price breakdown of these turbines is listed in Table 6, with a picture of each shown in Figure 29.

Table 6: PacWind Systems Cost Breakdown⁵¹

Turbine	Rated Power (kW)	Turbine (\$)	Tower (\$)	Inverter (\$)	Charge Controller (\$)	Total Cost (\$)
Seahawk	.5	3,500.00	1,850.00	1,900.00	500.00	7,750.00
Delta I	2	4,750.00	1,850.00	1,900.00	500.00	9,000.00
Delta II	10	34,999.00	7,650.00	1,900.00	500.00	45,049.00



Figure 29: PacWind Turbines (left to right: SeaHawk, Delta I, Delta II)⁵²

6.3 Wind Turbine Orientation and Type

As mentioned previously, there are two possible orientations of a wind turbine: horizontal axis and vertical axis. As implied by their name, horizontal axis turbines rotate around an axis that is in a horizontal plane. The alternative is a turbine that rotates on a vertical axis and looks more like a helix or a large eggbeater. Each of these designs is considered to determine which one best fits the application on Alcatraz Island.

The other defining characteristic between turbines is their method of harnessing power from the wind. The two designs are “drag type” and “lift type” wind turbines. Drag type turbines have the simplest design, by relying on “cups” placed about an axis that catch the wind when the cup is facing into it and repelling it when faced away.⁵³ Lift type machines incorporate the same concept as the wing of an airplane and use the pressure difference created over an airfoil to cause a lift force that is perpendicular to the direction of the relative wind.⁵⁴ These two designs can be seen in Figure 30. (Please note, however, the artist’s error in the Figure 30: the lift and drag forces should be perpendicular and parallel, respectively, to the incoming wind, rather than to the shape of the airfoil.) There are advantages and disadvantages of each of these turbine designs. In order for a horizontal axis, lift type turbine to function it has to be facing into the wind, the whole turbine must be able to rotate around a vertical axis to accommodate the direction of the wind. A vertical axis drag or lift type turbine works no matter what direction the wind is coming from, which reduces the number of moving parts and the complexity of the machine. The rotational speed of the drag machine is directly related to the speed of the wind and can only move as fast as the wind pushing it. The blades of a lift type turbine can rotate faster than the speed of the wind because it is not using the wind to push them, but use the wind to create a pressure difference across the blades; therefore,

they have a greater energy producing potential. Almost all horizontal axis turbines are lift type machines, while the vertical axis turbines are mainly drag type machines. Vertical axis lift turbines do exist, but these are not as common in small wind applications.

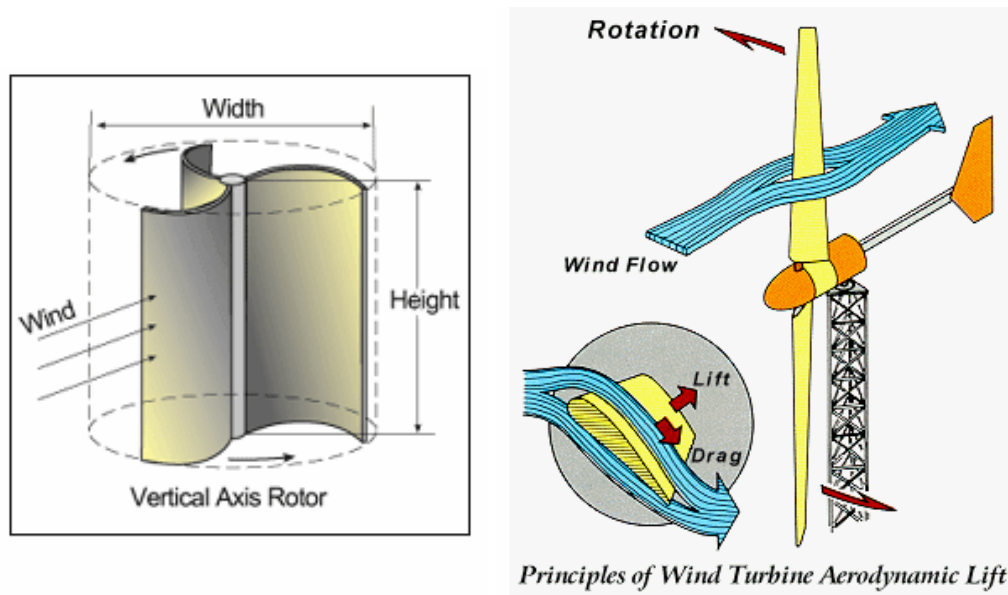

Figure 30: Drag and Lift Wind Turbines⁵⁵

The horizontal axis turbines considered for this project incorporate the lift principle to rotate the blades, so they can reach speeds higher than the wind speed itself, but the height requirement and large swept area of the blades makes them very noticeable at a distance. The Windside vertical axis turbine introduced earlier is based on drag, while PacWind has turbines that incorporate both methods. Another benefit of the vertical axis turbines is their appearance. Unlike the horizontal axis turbines that have large rotating blades that stand out, the vertical axis turbines are relatively thin and unassuming. The horizontal axis turbines were ultimately ruled out as a possibility because of their conspicuous appearance. Even installation of small diameter turbines, seen in Figure 31, would be very conspicuous on the roof of the Cell House. Therefore, all of the

calculations used in the analysis of wind power output used the specifications for a vertical axis turbine.

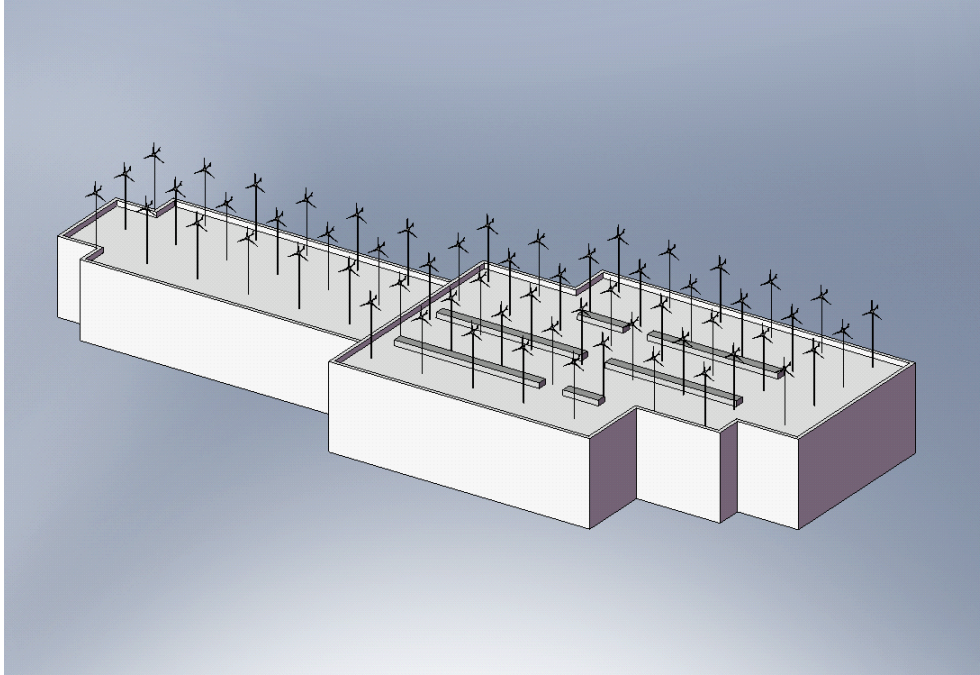

Figure 31: Horizontal Axis Turbine Array Located on the Cell House Roof

6.4 Wind Power Availability

Calculations have been performed to determine the yearly amount of energy that could be produced from wind energy using the 2.5 kW rated turbines. First, the maximum number of wind turbines that are able to fit on the Cell House roof had to be resolved. This is done with a model of the Cell House that is created in Solidworks using dimensions taken from Google Earth.⁵⁶ As the air passes by a turbine it becomes disturbed, which will affect how well it is able to rotate the adjacent turbines. The recommended spacing between wind turbines is a distance no less than 7-10 times the diameter of the turbine. Another consideration is how wind speed is affected as it passes each consecutive row of turbines. There is a 60-70% reduction in the speed of the wind after it passes

the first row of turbines and then only a slight reduction after each subsequent row.⁵⁷ This phenomenon was accounted for in the calculations of the power output. The wind availability analysis can be seen in Appendix D and the SFO wind data are assumed for all calculations.

Two different models are generated to represent wind turbine installations on the roof of the Cell House. One design optimizes the space on the roof of the building, and the second model keeps the turbines as free from view as possible. The maximum number of turbines that can be discretely placed on the Cell House roof is 22 and the maximum number possible is 51. Visual representations of the two configurations are shown in Figure 32 and Figure 33.

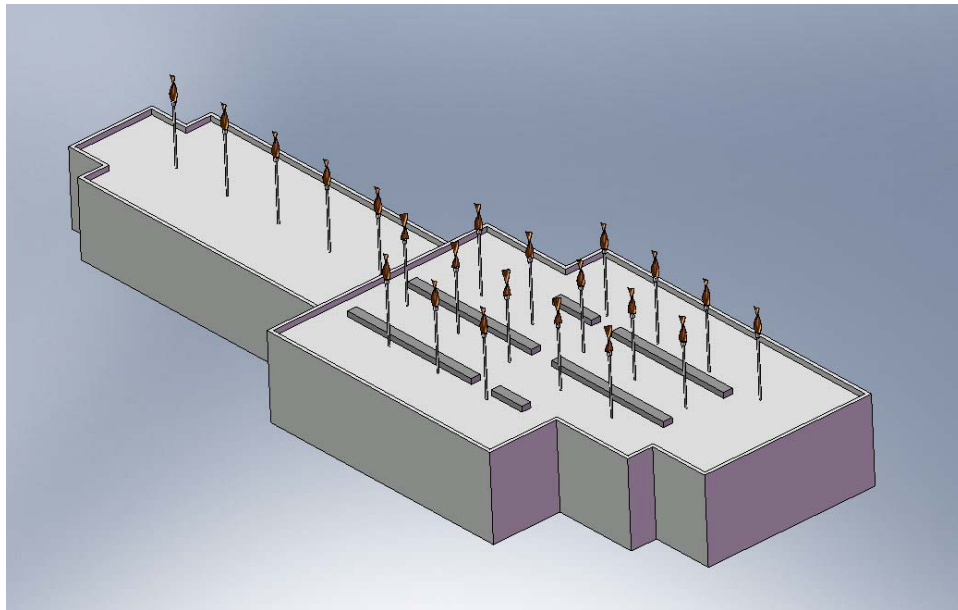

Figure 32: Small Vertical Axis Turbine Array Located on the Cell House Roof

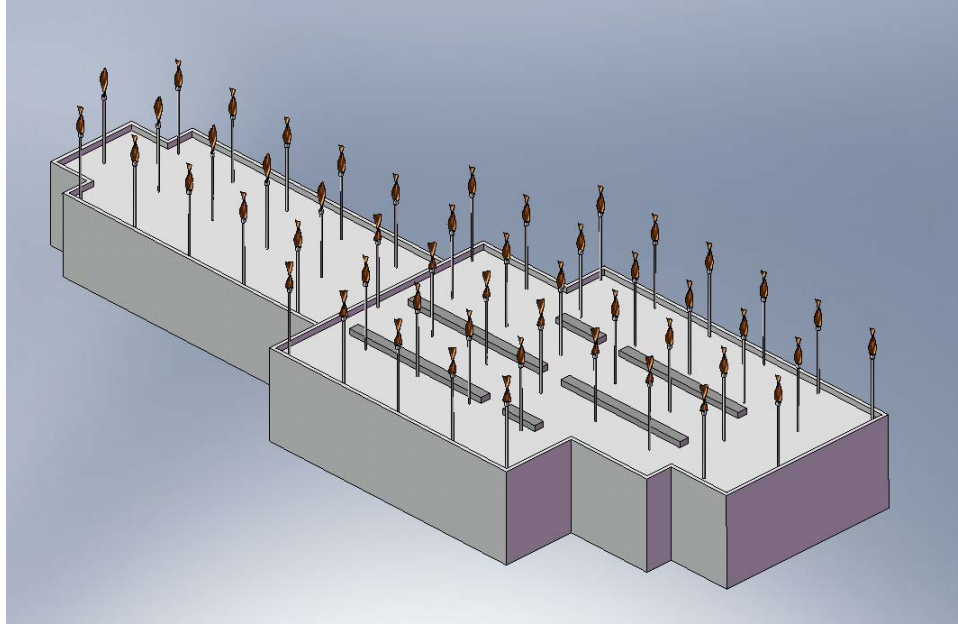

Figure 33: Large Vertical Axis Turbine Array on the Cell House Roof

An installation of 22 of the turbines would produce 1.8% of the energy requirement for the entire year, and an array of 51 would produce 3%. This means that 97% of the energy for the year would have to come from diesel or a combination of diesel and another renewable energy system. The monthly wind energy production versus energy demand analysis can be seen in Figure 34. This investigation concludes that the wind resource at Alcatraz Island is not sufficient to support wind turbines. Further research could be conducted in order to determine the existence of a location on the island with greater wind speeds.

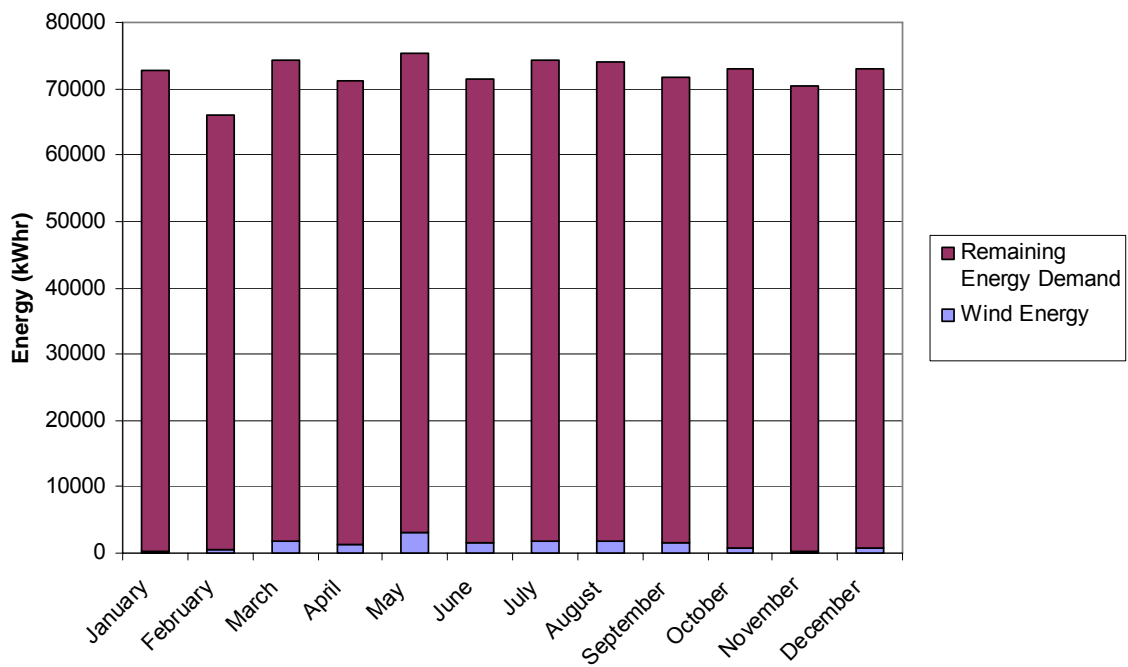

Figure 34: Monthly Wind Energy Production for a 51 Turbine Installation

7 Tidal Energy Assessment

7.1 Tidal Resource

Unlike solar and wind energy, tidal energy can be more accurately predicted. The benefit of this is the knowledge of exactly how much energy can be produced and when. The height and direction of the tide is based on the gravitational pull of the sun and moon on the earth. Most locations on the earth observe two high and two low tides per day that occur on a 12.4 hour cycle. The range of these cycles vary over a two week period including the maximum tide, or “spring tide”, when the sun and moon are aligned with the earth and the minimum tide, or “neap tide,” when the sun and the moon are at 90° in relation to the earth. Each of these situations occurs twice a month; therefore, only a two week period of tidal current data is required to characterize the essential aspects of the yearly tidal resource at a specific location.⁵⁸ The height of the neap and spring tides are relative to the distance between the earth and the sun and therefore vary through the year, but this can be accounted for in the analysis. Tidal turbines are also beneficial from an aesthetic and historical preservation point of view, as they sit below the water level and can’t be seen from the island.

In order to determine if there is a tidal resource that could be harnessed at Alcatraz Island, it has been necessary to consider tidal current measurements obtained in the area. The National Oceanic and Atmospheric Administration (NOAA) has tidal current measurements from several locations in the San Francisco Bay, including four stations north, south, east and west of the island, ranging from distances of 0.2 to 0.8 miles from the island.⁵⁹ These stations are labeled E, B, A, and D, respectively in Figure 35. Tidal current data are downloaded from the NOAA website and processed to determine the average tidal current power density available at each station.

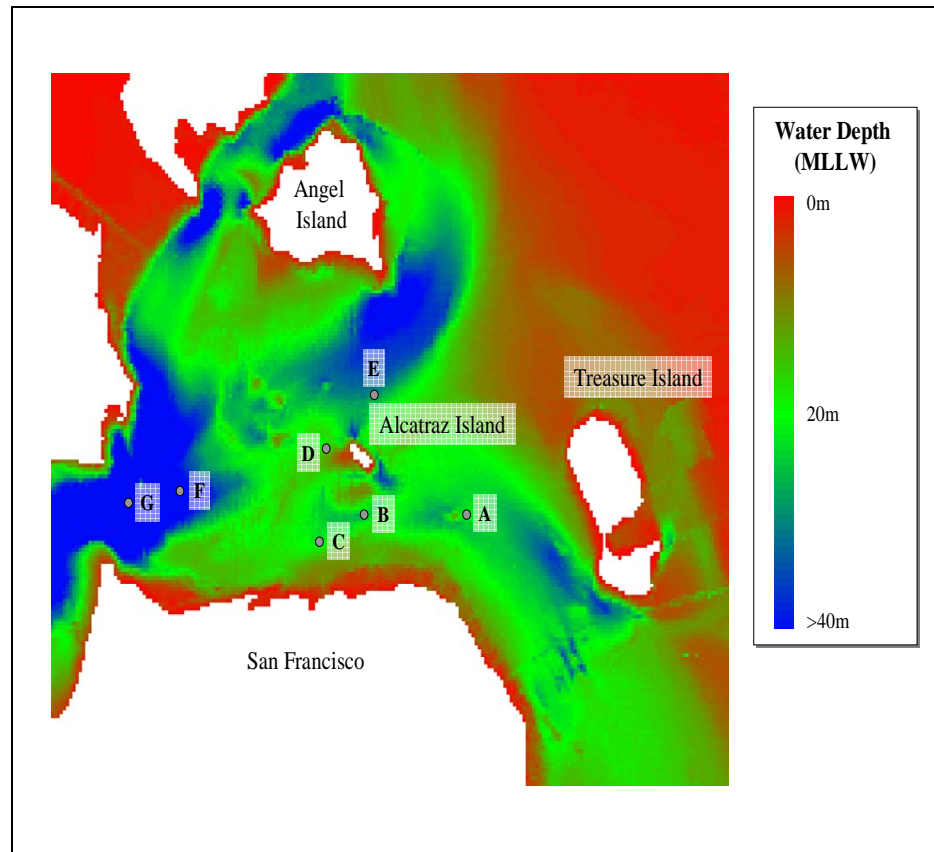

Figure 35: Bathymetry for west end of San Francisco Bay with NOAA stations noted.⁶⁰

In order to obtain an additional prediction of the tides in the San Francisco Bay, it is possible to view real-time current velocities there. These predictions are generated by the Tidal, Residual, and Intertidal Mudflat (TRIM) model, which is available on the United States Geological Survey (USGS) web page. TRIM is a numerical model that simulates the tidal currents and behavior of a body of water and has been applied to the San Francisco Bay.⁶¹ An example of the predictions can be seen in Figure 36.

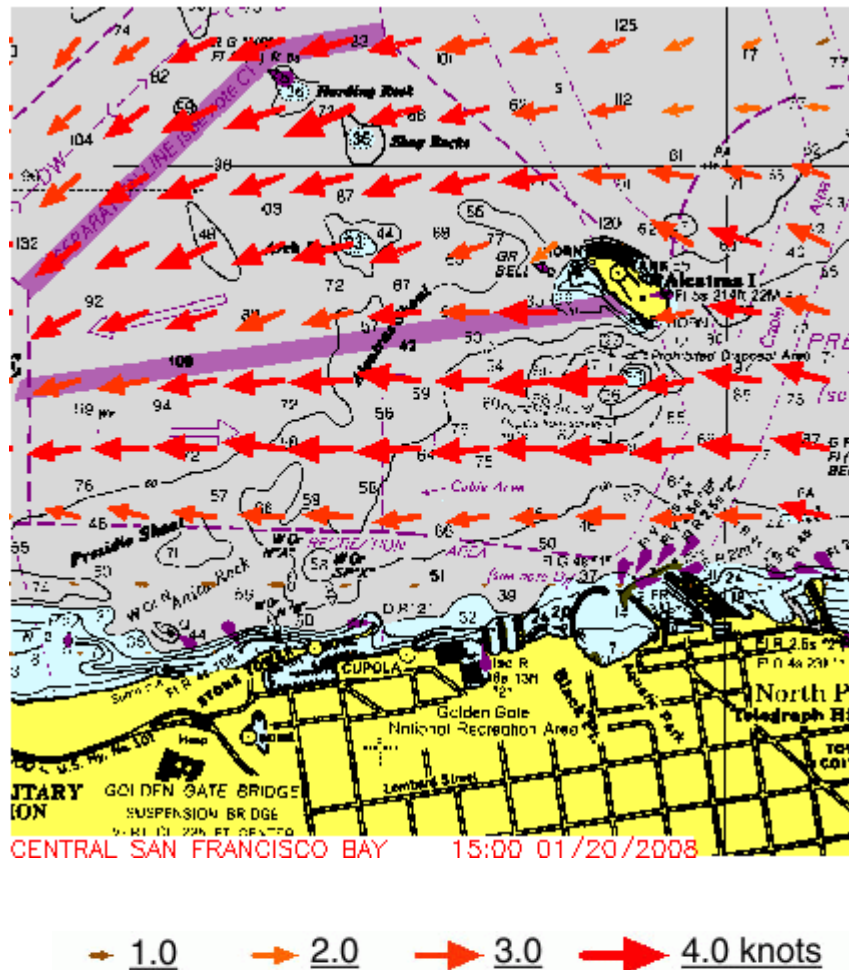

Figure 36: TRIM Model Prediction for Ebb Tide on January 20, 2008⁶²

7.2 Tidal Turbine Manufacturers

One deficiency of tidal energy compared to solar and wind energy is that the technology is relatively new and not as well developed and tested. Currently, there are no tidal turbines past the stage of commercial scale demonstration, unlike solar modules and their wind turbine counterparts, with only a relatively few companies conducting research and development. Two of the US tidal turbine ventures are Verdant Power and Gorlov Helical Turbines.

Verdant Power is responsible for the pilot tidal turbine installation in the East River in New York City. These turbines are similar to lift type horizontal axis wind turbines with three blades that rotate around a hub. The blade diameter is five meters, with a rated power of 34 kW. In order to account for the bi-directional flow of the current with the ebb and flood tides, these turbines are secured to a monopile and spin on a vertical axis so that they can turn into the direction of the flow.⁶³ The advantage of this design is that the turbine is always on axis with the direction of the current, although the rotating hub is at a greater risk of mechanical failure than a stationary design. A representation of the Verdant Free Flow turbine can be seen in Figure 37.

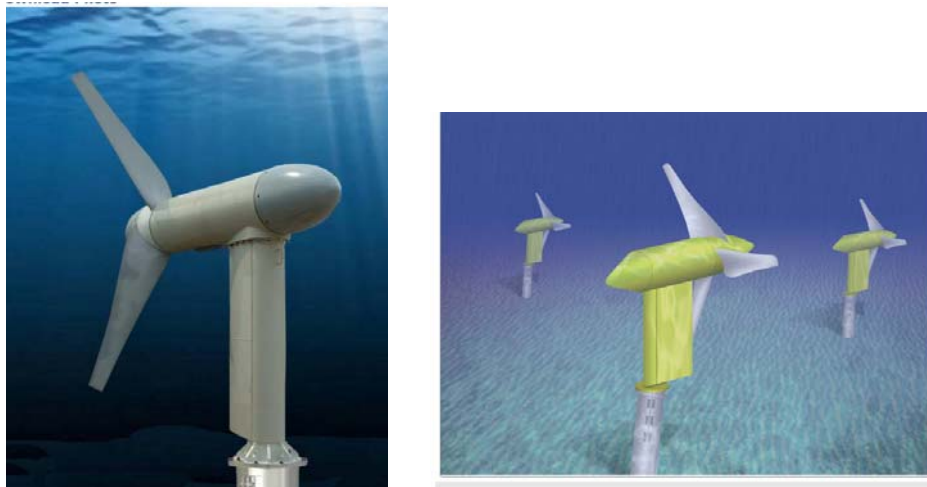

Figure 37: Verdant Power Free Flow Turbines⁶⁴

Verdant's competitor, Gorlov, also incorporates the lift type design and can be installed either on a vertical axis or horizontal axis. Its axisymmetric blade design allows the turbine to rotate regardless of the direction of flow of the current. This reduces the number of moving parts and the possibility of failure. The Gorlov turbine is stated to have a low cut-in speed.⁶⁵ An example of the Gorlov turbine is shown in the Figure 38 below.



Figure 38: Vertical Axis Gorlov Helical Turbine⁶⁶

7.3 Potential Tidal Turbine Location

None of the NOAA stations is situated close enough to the island to provide a clear indication as to whether there is a localized acceleration as the current splits to travel around the island. However, the bathymetry of the water around Alcatraz Island shows that there is a shallow area, “Alcatraz shoal”, located directly south of the island, as indicated on Figure 39. This information confirms the predictions from the TRIM model seen in Figure 36, which indicate the presence of a fast current at that location with a high power density. Despite best efforts, no additional data have been discovered regarding the tidal resource near Alcatraz. There are several sources of tidal current data in the San Francisco Bay; however, none of them has information regarding the shoal area that may confirm accelerated current. If these data cannot be obtained, it may be necessary to commission a tidal current study at this location to verify the resource.

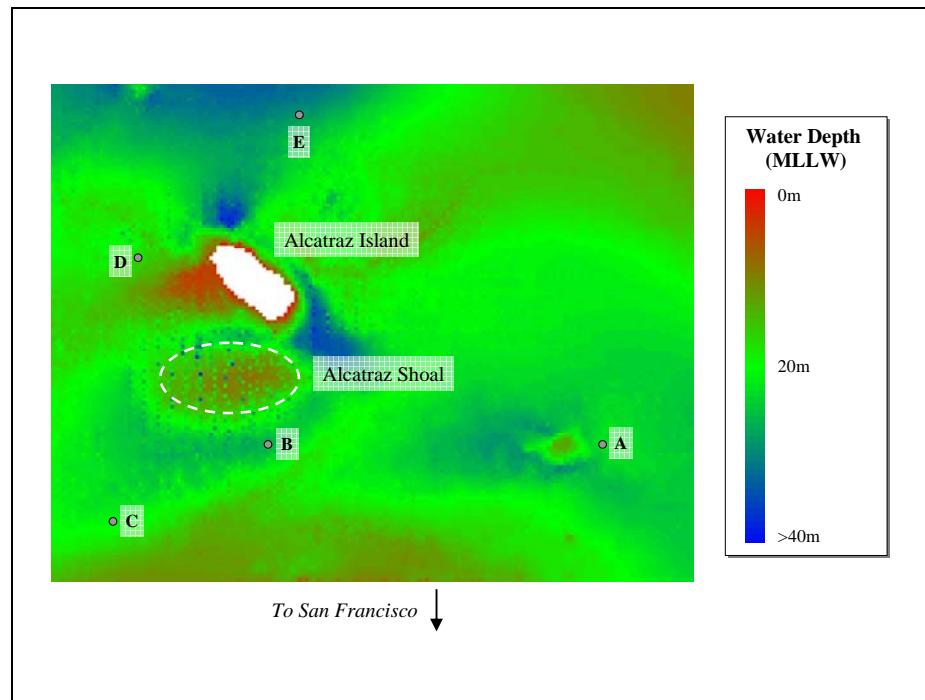

Figure 39: Bathymetry of San Francisco Bay around Alcatraz Island.⁶⁷

7.4 Tidal Power Availability

Tidal power calculations are performed with the NOAA data to determine the average power density at each of the four stations surrounding Alcatraz Island. The NOAA data contain tidal predictions of the maximum ebb and flood current velocities for each day over an entire year. These data are imported into a tidal current power estimation program, created by Brian Polagye, which converts the current velocity into the average power density for the year.⁶⁸ The station to the east of the island (A) has a nominal power density of 0.2 kW/m^2 , and the west station (D) has a power density of 0.4 kW/m^2 . These are fairly low power densities. Additionally, these two sites may not be suitable locations for tidal turbines because the water flows east-west in the bay, so the current at the downstream side of the island would likely be turbulent for either the flood or ebb tides. The north station (E) has a power density of 0.3 kW/m^2 and the power

density at the south station (B) is 0.2 kW/m^2 . For a site to be considered for tidal power, it should have a minimum power density of 0.8 kW/m^2 . Although the NOAA stations around Alcatraz do not support adequate power density for tidal turbines, there may be localized acceleration closer to the island as the current splits to travel around the island that is not indicated in the NOAA data. As indicated by the TRIM model, the shoal to the south of Alcatraz Island is a likely location for accelerated current and should be investigated further.

If the NPS is seriously considering in-stream tidal energy, it should commission a tidal current measurement study to be conducted at locations near to the island and at the shoal south of the island. This will confirm if localized power densities can support tidal turbines. In addition to the lack of tidal current information near the island, tidal energy is still a relatively new technology with no fully commercial tidal installations yet and a few demonstration installations currently in progress. These factors may make tidal energy a less desirable renewable energy solution for the island at present.

8 Reconnect to the San Francisco Power Grid

An alternative to the use of diesel generators on Alcatraz Island is to reconnect to the San Francisco power grid and purchase energy from Pacific Gas and Electric (PG&E). This was the original method of providing power to the island, and it is a logical alternative to the diesel generators currently being used. Alcatraz Island is located just off of the north coast of San Francisco in the Bay. Initially, Pacific Gas and Electric (PG&E), the local utility, agreed to provide the cost estimate for installing an undersea cable from San Francisco to Alcatraz Island; however, being unable to perform this task, it was undertaken by the University of Washington with the assistance of Mirko Previsic Consulting in Sacramento, CA.⁶⁹

A large portion of the cost for any cable installation is the price of the conductor material copper, which is around \$3 per pound. The remaining expenses include burying the cable under the surface on the seabed floor and tying into the power grid at both ends. This cost was estimated from a calculation performed for another sea-cable installation with similar distances and loads. The cost of copper for this installation is around \$0.81 million while the installation cost is \$1.2 million.⁷⁰ A value of \$.5 million was added to this estimate to account for the cost of connecting the cable at the substations on the both the mainland and island.⁷¹ The total cost of reconnecting Alcatraz Island to the San Francisco grid is estimated as \$2.5 million if done in autumn 2007.

After Alcatraz Island has been reconnected to the power grid, the electricity consumed will still have to be paid for. Although the cost of energy varies depending on the time of year and the amount of power consumption, the average cost of electricity in San Francisco is \$0.14/ kWh.⁷² The NPS can incorporate renewable energy into its system by purchasing “green” energy from

the power company at an additional cost of \$0.02/ kWh.⁷³ Also, a grid connection can be used jointly with a solar energy system, and thereby used to simplify the system significantly. If Alcatraz Island is connected to the San Francisco grid in addition to having a solar energy system, it can draw power from the grid during hours or days of insufficient solar energy production. This completely removes the need for diesel generator use on the island or an energy storage system. The economics of this arrangement are discussed in Chapter 11.

9 Energy Storage

Power that is produced at a coal or natural gas power plant does not need to be collected and stored for future use, because the production can be adjusted to accommodate the power demand. One of the shortcomings of renewable energy is that it is unpredictable and is not always available when it is needed. This is not a problem if the renewable energy system is connected to the power grid, because any excess power that is produced can be deposited into the grid to be taken out later when needed. Most energy meters measure power flow in both directions, meaning that power going into the grid is subtracted from the power taken out, giving a net consumption value. However, if a renewable energy system does not have access to a power grid, it becomes necessary to harness the renewable resource while it is available, convert it into energy and then store it until it is needed. A stand alone renewable energy system should have enough energy storage to last through a lull in its resource, such as a period of overcast days for a solar system.

Even a hybrid diesel-renewable energy system that uses renewable energy when available and diesel generators when it is not will require some energy storage. The energy demand at Alcatraz Island in the evening is not high enough to justify running the 210 kW rated diesel generator. The alternatives to this are switching to the 80 kW rated generator in the evening or installing an energy storage system that can supply the evening power demand. This system works by absorbing excess energy produced during the day, either by the generator or the renewable energy system, and storing it until the other systems are no longer running, at which point it distributes the energy that it has collected. The two types of energy storage systems that are considered for this project are a battery bank and a pumped storage system.

9.1 Battery Storage

Batteries are the most common, reliable and efficient form of energy storage available to date, which is why they are used most often in off-grid renewable energy systems. However, they are also useful for a hybrid solar-diesel generator system to provide energy during small load periods without having to run the generator at low efficiency. Generally, a battery bank for an off-grid renewable energy system without backup has to be sized for the worst case scenario of the year regarding the renewable resource. Since solar is the only resource capable of providing a significant portion of the demand, a battery bank is sized according to the solar resource. However, Alcatraz Island has diesel generators available for use, which means that not all of the energy has to be provided by solar energy and battery storage. It was decided previously in this study only to design a solar energy system large enough to provide the total energy demand for July using strictly renewable energy, so the energy storage system should correspond to the July demand and solar availability.

The size of a battery bank depends on several different factors, including the average peak sunlight hours, the discharge depth of the batteries, the maximum charge of the batteries and the daily electricity load. Batteries cannot be discharged until they are empty and then charged until they are full again, in fact, most lead acid batteries should not be discharged further than 30% of their capacity and charged more than 80% in order not to damage them. This means that a battery bank has to be sized at least twice as large as the amount of energy storage required, without taking into account inefficiencies in charging the batteries, temperature compensation factors and losses in the wires. Battery storage capacity can be classified as critical or non-critical storage, critical storage meaning that energy is available 99% of the time and non-critical meaning that energy is available 95% of the time. Since there is not any power

critical equipment located on Alcatraz Island, there is no need for a 99% guaranteed power supply, especially since generator back-up is available if there is a series of cloudy days. The battery capacity for storage is defined by the number of “days of autonomy” required, which is a function of the average number of peak sunlight hours over the period of desired autonomy. The average hours of peak sunlight per day in San Francisco in July is 7.26 hours, which will provide 1.09 days of non-critical storage, as calculated by Fackler.⁷⁴

The daily power load at Alcatraz Island of 2350 kWh and the 1.09 days of power available for non-critical storage, gives 2562 kWh of required energy storage. At minimum, the battery bank would have to be sized at least twice this large, at 5124 kWh, and then increased further to account for inefficiencies in the system. For a 48 volt battery, the minimum amount of battery storage would be 106,750 amp-hours. This is an extremely large battery bank and would be difficult to accommodate and maintain on Alcatraz Island. Some batteries are very large and require the use of a fork lift to move and replace them, making a large system even less desirable. This is why it is decided not to follow the non-critical storage guideline and instead design the system to provide enough storage for only part of the day. The downsized battery bank for partial day storage is discussed in Chapter 10.

9.2 Pumped Storage

Since batteries contain hazardous material and contribute to electronic waste if not properly disposed, the National Park Service has requested an investigation into alternative energy storage; resulting in the investigation of pumped storage as a supplement to battery storage. A pumped storage system is in essence a hydro power system that uses, as its source, water that has been pumped to a higher elevation. Energy is stored in the potential energy of the water, which is

then turned back into power as it is released through the turbine. Shown in Figure 40, the water tower has a capacity of 250,650 gallons, is roughly 140 ft above sea level, and is not currently in use; thus it has a good potential to act as the reservoir for the pumped water.⁷⁵

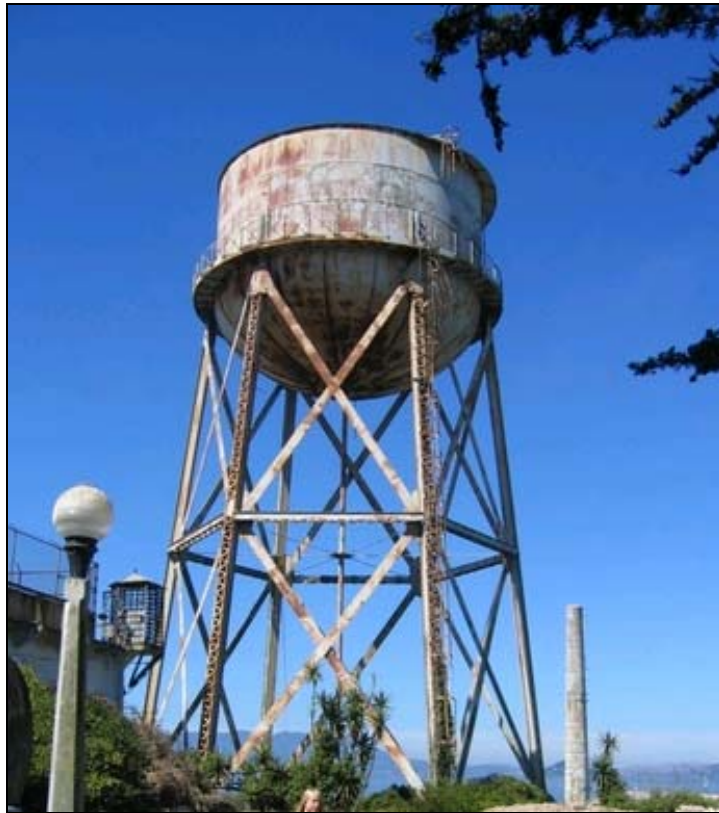

Figure 40: Water Tower on Alcatraz Island⁷⁶

The tank was previously a fresh water storage vessel, so in order for it to endure sea water, the tank would probably need to be treated or lined with a protective coating to protect it from corrosion. It is possible to protect a steel tank from corrosion by either treating the metal itself or by treating the fluid in the tank so it does not contain corrosion inducing properties. Adding corrosion inhibitors to salt water, such as alkaline material⁷⁷ or tobacco⁷⁸, can have dramatic results in reducing corrosion on unprotected steel. Some inhibitors have been tested and found to have no toxins or other negative effects on the composition of the salt water, thus these corrosion inhibitors are environmentally safe and the treated

water can be returned to the ocean. It must be noted, though, that maintaining an anti-corrosive mixture requires continual monitoring of the composition of the water and periodic addition of the chosen inhibitor. This can increase both material and labor costs drastically, making it less economically efficient when compared to an anti-corrosion lining. Thus, for the purposes of this study only anti-corrosive lining technologies will be further explored.

There are several types of anti-corrosion coatings. Some of the common compositions used for anti-corrosion products include epoxy, alkyd, vinyl ester, phenolic and zinc. These coatings are most commonly used in short-term situations, as they tend to chalk, peel or fade over prolonged use, thus the issue with this type of corrosion prevention is both cost and life expectancy. For reference purposes it is estimated that a three coat epoxy/polyurethane coating costs approximately \$56.48 per square meter and has an estimated service life of 10 years.⁷⁹

Many products on the market that advertise corrosion resistance are also used for wear resistance and thermal protection. Although a primer may be effective in corrosion prevention, its cost is slightly deceiving as it is also necessary to apply multiple layers as well as a topcoat in order to ensure proper protection. In addition to the need for multiple layers each coat applied must be allowed time to dry before applying the next coat. In addition to the extended time needed for drying, the metal surface needs to be cleaned of all prior paints and coats as well as be free from any chemicals or rust. The time needed to prep the surface for the primer coupled with the previously mentioned time requirements and increased amount of layers increase both labor and material costs. Overall the cost is similar to that of the three-coat epoxy/polyurethane coating specified above, though its expected life is slightly longer.⁸⁰

Other long-term solutions include the use of cathodic protection in anti-corrosion coatings and paints. This is the most commonly used method of corrosion prevention due to its low cost and long life expectancy. This method is frequently used in large scale cases similar to that of the water tower making this the optimal anti-corrosion coating.⁸¹

An example of a cathodic protection product is Si-COAT anti-corrosion coatings. Si-COAT anti-corrosion coatings are a one-coat, room temperature applied protective rubber coating. Specifically, Si-COAT 579 and 580 are used for corrosion prevention on metals such as steel. The application process of this product is fairly simple as there are no extreme conditions necessary when applying the coating, including no need to mix chemicals and only minimal surface preparation. It is not necessary to sandblast prior coatings off, as they will be encapsulated by Si-COAT, leading to a 70% cut on application costs. It is necessary, however, to remove any rust or oil, in which case sandblasting may be necessary for the inside of the storage tank.⁸²

Si-COAT has been proven to withstand extreme conditions such as exposure to severe temperatures and corrosive chemical compounds. This type of coating is intended for use on unprimed metal structures, tanks, buildings and roofs; thus application to the interior of a steel tank is a reasonable use of this product. The cost is approximately \$31.28 per square meter, 45% cheaper than the previous methods, and has an estimated service life of 25 years, a 250% improvement when compared to epoxies.⁸³

One aspect to be cautious of in cathodic protection is cathodic disbondment, which is the loss of adhesion due to the properties used in cathodic protection for anti-corrosion purposes.⁸⁴ The Si-Coat 579 has been specifically developed to resist cathodic disbondment, which reduces risk of failure for this technology.⁸⁵

Thus, it is possible to protect the water tank against salt water corrosion. The other aspects of the system are now discussed.

The energy storage comes from harnessing excess energy produced during the day from a renewable energy system or generator to pump water up to the height of the water tower where it then has potential energy. The water is stored at this elevation until a time when energy can no longer be produced by the renewable resource, and then it is discharged back down to sea level and run through a hydroelectric turbine where its potential energy is converted into kinetic energy. The total amount of energy that can be produced by this method is dependent upon the height of the storage reservoir, the amount of water, and the efficiency of each component. The number of hours a system can be run, or the power rating, can be modified by changing the size of the discharge pipe.

The pump in a pumped storage system generally has an efficiency of 80%, so there will be a 20% loss from the energy produced by the generator of the renewable energy system to the potential energy of the water in the tower. The efficiency of the hydroelectric system is a combination of the efficiency of the piping, the turbine itself and the generator. As water descends through a pipe, the friction between the flowing water and the walls of the pipe causes a pressure loss in the system, reducing the pressure difference across the turbine and the potential energy available.⁸⁶ Only about 90% of the original potential energy of the fluid is converted into kinetic energy. The turbine efficiency varies depending on its size and consistency of power load. Pumped storage systems are effective for utility grade systems; however, they are not as efficient for small scale installations. At small scale, a fixed load impulse turbine has an efficiency of up to about 80%, meaning it can convert 80% of the kinetic energy of flowing water into rotational energy of the turbine.⁸⁷ The generator has an efficiency of up to 98% as it converts mechanical energy into electrical energy. Thus, the overall efficiency of the pumped storage system is only 56%.

Including the energy losses from the piping, turbine and generator, the greatest amount of energy that can be produced using a tank with the volume and height of the one on Alcatraz is 85 kWh (see Appendix F for analysis). If the nighttime load could be reduced to 17.5 kW, this system would last for 4.86 hours. This value does not include energy loss as a result of a non-fixed load caused by turning lights and appliances on and off. A hydroelectric turbine cannot respond instantaneously to fluctuations in the load, so this is accounted for with a battery buffering system that handles spikes and dips in the energy load while the turbine provides the base load.⁸⁸ Even if the nighttime load could be reduced, this would not alleviate the need for an additional energy storage system or for the generators to run for part of the night. Clearly, a pumped storage system using the present water tower can only supplement a hybrid diesel-renewable system and will not remove the need for some batteries, and in fact, small hydro systems always interface to the electric load through a battery bank.

10 Solar Energy System Design

10.1 Solar Energy Justification

After considering all of the renewable energy resources in San Francisco Bay, a solar energy system is determined to be the best energy solution. Wind energy is eliminated from consideration as a renewable energy solution at Alcatraz Island for several reasons. There is not a great enough wind resource at Alcatraz Island to justify a wind turbine installation. Although the turbines would be moving 75% of the time, they would only be running at their rated power about 1% of the time. Also, there is not space on the island to install enough turbines to make a substantial contribution to the energy demand; the entire roof of the Cell House covered with small turbines would produce 3% of the energy need for the year. Also, Alcatraz Island is home to several species of birds that inhabit the island from February until August. The presence of wind turbines could disrupt their habitat and potentially cause them harm. The final reason is because wind turbines would be very conspicuous on the island. Although this study considers small turbines located close to the roof, wind turbines should be installed at least ten meters above the tallest obstacle in an area, the Cell House in this case. It is unlikely that a ten meter tall turbine on the roof of the Cell House would comply with the historical preservation regulations of the island. Tidal energy also is ruled out as a possibility for Alcatraz Island. This is not a final conclusion, however, and is subject to change if new, favorable tidal data become available showing that tidal current kinetic power of at least 0.8 kW/m² exists near Alcatraz. For now, there is no proof that the tidal resource is present.

A solar energy system is determined to be not only the most practical renewable energy system for installation at Alcatraz Island, but it will produce the greatest amount of energy. Solar modules will lay flat or can be tilted on the roof of either

the Cell House or the New Industries Building. The Cell House is by far the tallest building on the island, so a solar installation on its roof won't be seen by the public. The roof of the New Industries Building can be seen from one vantage point on the island, which is at the door that leads from the recreation yard to the stairway down to the west side of the island. This makes it a less desirable location in terms of aesthetics and historical preservation. It is possible to produce the entire energy requirement for the island for the month of July with an installation that fits on the roof of the Cell House, so there is an ample space and solar resource.

10.2 Solar System Components

10.2.1 Solar Modules

The solar module is the backbone of a solar energy system. It is made from multiple solar cells by which the solar radiation is collected and converted into electricity. The modules are arranged in groups in series and parallel to create an array and a combination of arrays makes the system⁸⁹. A solar energy system is only as effective as the panels of which it is comprised. Different solar modules have a different voltage, current and efficiency based on their solar cell efficiency and arrangement. The efficiency of a solar cell is dependent upon multiple factors, including the semiconductor material used, the production method of the semiconductor, and the manner and material used to create a positively and negatively charged junction across the semiconductor.

The two solar modules chosen for this study are the SunPower 315 and Sanyo 200. These modules incorporate different, yet the most efficient solar cells available on the market today. The SunPower panels use monocrystalline silicon as the semiconductor material. The advantage of a monocrystalline structure is the lack of impurities or gaps in the crystalline lattice that might impede electrical

current. The drawback, however, is that monocrystalline silicon is very difficult, expensive and time consuming to manufacture, because it takes more time for a single element crystal to grow. SunPower panels have efficiency ratings up to 19.3%, which is by far the highest efficiency available to date.

The Sanyo panels of interest use a combination of monocrystalline silicon and thin film silicon layers termed HIT technology. By supplementing the monocrystalline silicon with the easily manufactured thin film silicon, the amount of base material is reduced. Although the HIT modules initially have efficiency rated near 17.4%, they degrade over time to around 14% by the end of their lifecycle. The final efficiency of the Sanyo panels is still as good as or better than the efficiency of other brands at the beginning of their installation.

10.2.2 Battery Bank

The purpose of a battery bank in a renewable energy system installation has been discussed in Chapter 9. It is decided that the size required for a battery bank to provide non-critical autonomy is too large for the installation at Alcatraz Island. A battery bank that can provide enough energy storage for half of the day, specifically during the evening, would allow the island to be powered by solar energy or diesel generators during the day and by batteries at night. Even if batteries weren't necessary to store any excess energy produced from solar energy, they are beneficial for the diesel generator system.

An example of a solar installation similar to this particular situation can be seen in the hybrid diesel-solar system installed in Grasmere, Idaho.⁹⁰ This is a project funded by the Energy Conservation Investment Program (ECIP) and implemented by Idaho Power and Sandia National Laboratory. The power load ranges from 30-90 kW and is supplied by two 210 kW rated diesel generators

and a 75 kW rated solar array. This is very similar to the 98 kW average daily load at Alcatraz Island, the 210 kW generators and the suggested 100 kW rated solar system. Grasmere has a 1,440 kWh battery bank to accompany the daily energy consumption of 1,047-1,609 kWh. The usable energy is only half the size of the battery bank, so there are 720 kWh of energy storage available from the batteries; this is roughly half of the daily load.

By having the batteries available to supplement the solar and diesel energy supply, the diesel generators can run for less time and at their highest efficiency. The generators at Grasmere only have to switch on when there is no solar energy available and the batteries have reached their discharge depth, at which point the generators supply power to the site and recharge the batteries. For example, if the load is 90 kW, the generators can be operated at 180 kW, with half of the output powering the site and the other half charging the batteries. After 8 hours, the batteries are full and the generators can be turned off again. The diesel generators at Grasmere observe 9-13 hours of run time each day, rather than 24 hours, and the batteries are cycled completely every 1-2 days. This extends the life of the diesel generators and of the batteries by allowing them to be used most efficiently and under steady conditions.⁹¹ This is the same practice that should be adopted at Alcatraz Island. A battery bank that is sized for a full day of energy demand, 2350 kWh, will have half of a day's supply of usable energy. The island can then be powered by the batteries for at least half of the day and the generators won't have to be operated at low capacity. Due to the size increments of batteries available and their necessary arrangement, it is difficult to obtain a capacity of exactly 2350 kWh. The actual battery bank will have a storage capacity of 2500 kWh.⁹² The price of a battery bank this size ranges between \$300,000 and \$500,000, depending on the type of battery incorporated.

10.2.3 Inverter

The power output of a solar module is in DC form, the same at the battery bank, but most appliances and equipment run on AC power, and power grids are generally AC. All of the DC energy has to be converted into AC before it can be put into the grid, which is done with the aid of an inverter. An inverter is sized according to the amount of power that will be passing through it. In a hybrid diesel-solar installation, energy has five paths: solar panels to the grid, solar panels to the batteries, generators to the grid, generators to the batteries, and batteries to the grid. As seen in Figure 41 below, three out of the five energy transfers require the use of an inverter.

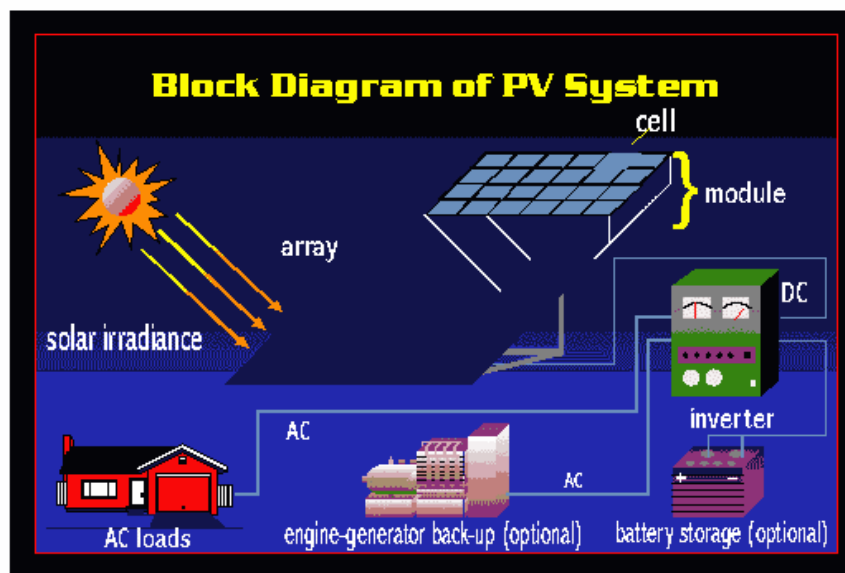

Figure 41: Diagram of the Components and Connections of a PV System⁹³

There is a 98 kW average load at Alcatraz Island with daytime loads around 158 kW and evening loads at 41 kW. If the solar energy system is sized at 100 kW, it means that in ideal conditions and peak daylight 100 kW is the most power that it can produce. In this case, it would all go straight to powering the island with the

remaining demand coming from the diesel generators. The inverter would have to be sized at least as big as the solar energy system at 100 kW so that it could handle all of the energy passing through it during peak load and solar production. Energy that goes directly from the diesel generators to the grid does not have to pass through the inverter because it is already AC, but energy that travels from the generators to the batteries has to be converted into DC in the inverter and then back to AC when it returns from the batteries into the grid. In the instance of no sun, the inverter would have to be sized for the power traveling from the generator to the batteries and then from the batteries to the grid. The batteries will probably only be used during the evening, so the power passing between them and the grid won't be greater than 50 kW. However, if the generators are being used to charge the batteries it is preferred to run them at near their full capacity, which is 210 kW, so the capacity of the inverter should be large enough to handle that load. For this reason, it has been decided to incorporate a 200 kVA rated inverter in the design for Alcatraz Island.

This sized inverter was inspired by the inverter located at Grasmere. For the Grasmere 90 kW load and 75 kW solar system, a 150 kVA rated SunEnergy inverter is used.⁹⁴ This provides room for expansion of the solar array if desired and allows the generator to charge the batteries at 75% rated power. SunEnergy is the only company currently producing inverters of this magnitude for an off-grid installation. The company has inverters in every unit of ten up to 100 kVA and then in increments of 200 kVA from 200 to 1000 kVA.⁹⁵ SunEnergy was contacted to obtain inverter specifications and price information which has been used in the economic analysis below. The estimated cost of a 200 kVA inverter is \$75,000 plus the cost of shipping.⁹⁶ If the NPS decides to install a photovoltaic system larger than 200 kW, the inverter will need to be upgraded and priced accordingly.

10.2.4 Charge Controller

The charge controller is used to protect the batteries by limiting the amount of current that can flow to and from the battery bank.⁹⁷ As mentioned previously, batteries that are cycled should not be drained to less than 30% of their capacity or filled to more than 80%. The charge controller prevents the batteries from being either undercharged or overcharged, thus extending their lifespan. In doing this, it has to compensate for the effect of temperature on the ability of the batteries to receive charge. The final function of a charge controller is to regulate the rate at which batteries are charged or discharged, as there is an optimal rate which maximizes their useable life. The cost for the charge controller also comes from SunEnergy, as the inverter and charge controller are sold as a set. The estimated cost of a charge controller that can handle loads up to 200 kVA is \$25,000.⁹⁸

10.2.5 Power Conductors

Power conductor refers to the wire that transfers power between the solar modules, batteries, inverter, generators and the local grid. The cable is gauged according to the amount of current that is passed through it. The wire that attaches each panel of the sub-array in series and parallel is almost insignificant compared to the wire that joins all of the sub-arrays and connects them to the inverter. These lengths are measured off of the Solid Model drawings that have been created for the Cell House and the New Industries Building. In each scenario, the inverter, charge controller and battery bank are assumed to be in the Power House, where the diesel generators are located (or in the basement of the New Industries Building, which is near the Power House).

The gauge of the cable and the corresponding cost per length is dependent upon the amount of power that is flowing through it. As mentioned previously, the cost

of the conductor depends on the cost of copper, which is around \$3 per pound. The wire cost will be minimal compared to the cost of all of the other components, resulting in 1-2% of the total system cost.⁹⁹ This number is calculated and included in the economic analysis in Chapter 11.

10.2.6 Solar Module Support

The last major component of a solar energy system is the racking unit for the solar modules. This will vary depending on the shape of the roof or installation site and the desired tilt angle of the solar modules. A tilted panel installation on a flat roof requires a racking system that can support and secure the panels at the desired angle. For a slanted roof installation, it is unlikely that the roof will be tilted at exactly the desired angle of installation, so a modifying rack will still be needed. Even modules that are installed flat on a horizontal roof or aligned with the angle of a slanted roof cannot just be bolted to the surface but require a racking system. The efficiency of a solar module is inversely related to its temperature. A solar system exposed to a certain amount of light can produce more energy at a lower temperature than at a higher temperature. A racking system can be used to elevate the module from the surface of the installation, allowing air to flow below and above the panels, providing convective heat transfer on both sides and keeping the modules cooler. Aside from setting the modules at the correct orientation for solar harvesting, solar mounting racks protect the modules and keep them in place. Solar modules are very expensive, so a racking system is used to prevent them from detaching in the event of a powerful wind storm.

The cost of a racking system for solar modules varies depending on each of the factors listed above, as well as the module layout and the roof material. The company Unirac is a custom solar module rack manufacturer and dealer. They

have available on their website a program that can be downloaded, which is able to make cost estimates for a solar module rack based on the size and system parameters.¹⁰⁰ For the estimate, the modules are assumed to be elevated off of the surface of the roof, a standard rail type with top mounting clips is assumed, and the panels are grouped in rows of 8 modules. The cost of a racking system for a horizontal array of 96 panels is between \$6,200 and \$6,500. This cost is increased by as much as \$3,000 per array by having the panels tilted at 28°.

10.3 Solar Array Design

Once the solar modules, inverter and battery bank are selected and sized, it is possible to design the solar system. There are several factors that contribute to the size of each system considered and its arrangement on each building. A 100 kW system is a practical first system because of the 98 kW average load at Alcatraz. The second solution is a 330 kW system because it can provide all of the required energy for the month of July and varying portions of the energy need for the remaining months. It is not practical to build a system larger than this unless the island is reconnected to the San Francisco grid because the excess energy produced will go to waste. The final option is to fill the entire roof of the Cell House with solar modules; however, this size will vary depending upon the panel orientation. The effects of tilting the solar panels up at their optimal angle are also considered for each sized system. When a panel is laid horizontally its orientation is unimportant, however, when a panel is tilted it is recommended to have it facing directly toward the sun. In San Francisco the sun is to the south for the entire year so the panels should be oriented to the south. The optimal tilt angle is calculated to be 28°. The New Industries and Cell House buildings do not face north-south but are turned at 30° and 45° degrees, respectively, which

has to be accounted for when spacing the panels. The 15 scenarios considered are broken down in Table 7.

Table 7: Solar System Location, Size and Layout.

Building	System Size	Panel Configuration
New Industries	100 kW	horizontal
	100 kW	tilted, facing south
	100 kW	tilted, facing 30° east of south
	Full Roof	horizontal
	Full Roof	tilted facing south
	Full Roof	tilted facing 30° east of south
Cell House	100 kW	horizontal
	100 kW	tilted, facing south
	100 kW	tilted, facing 45° west of south
	330 kW	flat
	330 kW	tilted, facing south
	330 kW	tilted, facing 45° west of south
	Full Roof	flat
	Full Roof	tilted, facing south
	Full Roof	tilted, facing 45° west of south

Solid Models are constructed for both the Cell House and the New Industries buildings, and each scenario is laid out for the two panels of interest. The purpose of the model is to determine the layout and the exact number of panels that could be installed on each roof and to measure how far the power conductors will have to travel from each array to the batteries, inverter and charge controller. The dimensions and shape of the roof of each building are measured off of Google Earth, and the resulting area is verified with the 2002 Cathcart Study.¹⁰¹ The usable area on the roof of the New Industries Building is 15,300 ft² and 43,000 ft² on the Cell House. In order to lay out the solar panels, first the panel arrays have to be constructed. The array size is dependent upon the open circuit voltage (V_{oc}) and short circuit current (I_{sc}) of the solar modules and the specifications of the inverter. The V_{oc} of a solar module is its maximum possible voltage that occurs when there is no current through it, and the I_{sc} is its

current when there is no voltage present. This relationship is represented in Figure 42.

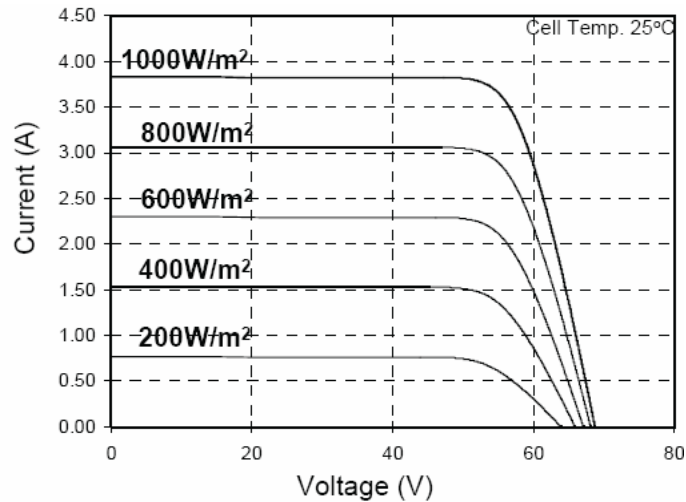

Figure 42: Current versus Voltage Curve for a 200 W Sanyo Solar Module¹⁰²

The 200 kVA SunEnergy inverter has an allowable V_{oc} of 600 Volts and I_{sc} of 500 amps.¹⁰³ The Sanyo panels have a V_{oc} of 68.7 volts and I_{sc} of 3.83 amps¹⁰⁴, while the SunPower panels have 64.6 volts V_{oc} and 6.14 amps I_{sc} .¹⁰⁵ This means that up to eight panels can be placed in series for the Sanyo panels and nine SunPower panels can be laid in series. For ease of the analysis, each array was divided into 12 sub-arrays connected in parallel formed by eight panels in series.¹⁰⁶ The purpose of breaking the entire system into arrays and sub-arrays is to keep the total power flowing through the cables at a safe and reasonable value. Due to the array restrictions, the systems could not be broken into exact 100 kW and 330 kW rated systems, so they were divided into groups of 96 panels closest to the desired values. The array sizes and rated power outputs are listed in Table 8. The SunPower panels are slightly larger than the Sanyo panels, as well as slightly more efficient; therefore fewer panels are required to obtain the same system rating as the Sanyo panels.

Table 8: Solar Array Size and Corresponding Power Rating

Desired Size (kW)	Sanyo Panel – 200 W		SunPower 315 W	
	Number of Panels	System Rating (kW)	Number of Panels	System Rating (kW)
100	576	115	384	120
330	1728	346	1056	332

10.4 Solar Energy Availability for New Industries Building

The amount of energy available from a solar energy system depends upon the amount of space available, the panels used, their tilt angle and orientation. Although the New Industries Building has significantly less surface area than the Cell House, at nearly 15,300 ft², it can still accommodate a large number of panels. The yearly energy availability for the six different system sizes and orientations on the New Industries Building is calculated using the SFO data and the properties of the Sanyo and SunPower panels. The results of the analysis are shown in Table 9. Since the yearly energy demand at Alcatraz Island is 857,600 kWh, the largest, most efficient solar system installed on the entire roof of the New Industries Building could produce 38.9% of the yearly energy demand on the island.

Table 9: Solar System Power Output for New Industries Building

Building	System Size & Orientation	Sanyo Panel – 200 W			SunPower Panel - 315 W		
		Number of Panels	System Rating (kW)	Yearly Power (kWh)	Number of Panels	System Rating (kW)	Yearly Power (kWh)
New Industries	100 kW, flat	576	115	190,853	384	120	193,295
	100 kW, tilted south	576	115	208,688	384	120	211,182
	100 kW, tilted 30°E	576	115	201,115	384	120	203,500
	full, flat	768	153	254,471	672	211	333,826
	full, tilted south	640	128	231,876	576	181	316,773
	full, tilted 30°E	672	134	241,566	576	181	305,250

10.5 Solar Energy Availability for Cell House

The yearly energy possible for a solar installation on the roof of the Cell House is assessed next. The Cell House has 43,000 ft² of usable space on the roof. The nine different scenarios for the Cell House are modeled and their yearly power outputs are calculated using both Sanyo and SunPower panels. The results are shown in Table 10 below. In some cases, the power available from a tilted system is less than that from a horizontal system because fewer panels can be installed on the roof. The most efficient panels installed horizontally on the entire roof of the Cell house could produce 73.3% of the yearly energy demand. Due to space limitations on the roof, it is not possible to install a 330 kW tilted, south facing system on the roof of the Cell House using either of the modules of interest. The largest titled, south facing systems that the Cell House can accommodate are rated at 302 kW and 307 kW.

Table 10: Solar System Output for Cell House Building

Building	System Size & Orientation	Sanyo Panel – 200 W			SunPower Panel - 315 W		
		Number of Panels	System Rating (kW)	Yearly Power (kWh)	Number of Panels	System Rating (kW)	Yearly Power (kWh)
Cell House	100 kW, flat	576	115	190,853	384	120	193,295
	100 kW, tilted south	576	115	208,688	384	120	211,182
	100 kW, tilted 45°W	576	115	201,115	384	120	203,500
	330 kW, flat	1728	346	572,560	1056	332	531563
	330 kW, tilted south	N/A			N/A		
	330 kW, tilted 45°W	1728	346	608,487	1056	332	564964
	full, flat	1728	346	572,560	1248	393	628211
	full, tilted south	1536	307	556,502	960	302	527955
	full, tilted 45°W	1728	346	608,487	1068	336	564964

11 Economic Analysis

When assessing a renewable energy system, it is necessary to consider the resulting cost of energy as well as the amount of energy available. Unlike energy purchased from the power company that has a set rate, the cost of renewable energy is a function of the price of the installed system and operation versus the amount of energy produced. A renewable energy system that is able to produce more energy than another system with the same installed cost is going to have a lower cost of energy. An annualized economic analysis is used to calculate the total yearly cost and the energy cost for several combinations of hybrid, renewable, diesel and grid-tied systems.

The annuity method determines the yearly cost of an energy system by transforming the capital investment into a yearly expense that is spread out over the lifetime of the system and combining it with the operating cost of the system.¹⁰⁷ This method is explained in Appendix G. Solar panels have a lifespan of 20 years; however, the inverter and charge controller have an estimated lifetime of 10 years and batteries have a minimum useful life of 5 years, so the cost of replacing them has to be included in the capital investment of the system. The batteries for the hybrid diesel-solar system at the Grasmere installation did not have to be replaced until they had been used for 12 years, so a battery lifespan of 10 years is assumed, meaning the batteries have to be replaced once in the lifetime of the system.¹⁰⁸ A present value calculation is used to find the current cost of replacing all of the major equipment in 10 year's time, except the solar panels, racking and conductors. The installation cost of the system is also considered a capital expense, so a common estimate of 10% of the equipment cost is incorporated into the analysis. A conservative interest (discount) rate of 8% is used for the capital investment and a standard top down approximation for operating and maintenance cost of 2% of the capital

investment is assumed.¹⁰⁹ Diesel fuel is taken at \$3/gallon, the price in early autumn 2007.

11.1 Solar Energy System

As mentioned previously, the main components of a solar photovoltaic system include the solar modules themselves, the inverter, charge controller, battery bank, power conductors and racking system. It is clear that a stand-alone renewable energy system will not be possible at Alcatraz Island, so the solar energy system will only supplement the energy produced by the diesel generators or energy purchased from the power grid should Alcatraz Island be reconnected to Pacific Gas and Electric. The price estimate for the Sanyo HIP – 200BA3 panels is used to compare the energy cost of 115 kW and 346 kW rated hybrid solar-diesel systems with the 115 kW and 346 kW grid-tied solar systems. Since these systems are rated slightly higher than the 100 kW and 330 kW systems analyzed in Chapter 5, the power output also will be slightly greater. In the case of the hybrid diesel-solar energy system, the cost of diesel fuel, transportation and the equivalent cost of the pollution into the environment is included in the calculation. For the grid-tied solar energy system, the cost of reconnecting the island to the San Francisco power grid is included.

11.1.1 Hybrid Diesel-Solar Power System

11.1.1.1 115 kW Hybrid Diesel-Solar Energy System with Battery Storage

A cost analysis of the 115 kW rated hybrid system is presented first. This analysis includes not only the cost of the solar photovoltaic system components and installation but also the cost of the diesel fuel required to supply the difference between the energy demand and solar energy system production and the cost of pollution. For every gallon of diesel fuel that is burned, there is a

given amount of CO₂, SO₂ and NO_x emitted into the atmosphere, and each of these pollutants has a cost associated with it. These values are listed in Table 11. The equivalent cost of pollution is calculated by converting energy demand into diesel fuel consumption and then determining the quantity of each pollutant emitted and multiplying it by its cost.

Table 11: Diesel Emissions and Costs¹¹⁰

Gas	Emissions (lb/1000 gal diesel)	Cost (\$/lb)
CO ₂	23,800	0.01
SO ₂	29	0.85
NO _x	575	3.40

The energy production of the four different panel orientations and their resulting energy costs are considered. A 115 kW rated horizontal panel orientation solar system can produce 22.2% of the yearly energy demand. If the panels are tilted up at an angle of 28° and faced true south, they can produce 24.3% of the yearly demand. A 28° tilted panel configuration facing 30° east of south can make 23.4% of the demand, and a 45° west of south facing system can make 23.6% of the yearly energy demand. The more energy that a system can produce means the less energy that has to be supplied by diesel fuel, which brings the total cost down. The resulting cost of electricity for a 15 kW rated system at each orientation is shown in Table 12.

Table 12: Economic Analysis for a 115 kW rated Hybrid System

Hybrid Solar PV/Diesel Generator System w/Battery Backup				
Panel Orientation	Horizontal	Tilted 28° Facing due South	Tilted 28° Facing 30° East of South	Tilted 28° Facing 45° West of South
Number Panels	576	576	576	576
Rated Power (kW)	115.45	115.45	115.45	115.45
Percentage of Yearly Energy Demand	22.25%	24.33%	23.45%	23.65%
Required Area (ft ²)	15393.79	15393.79	15393.79	15393.79
Module Location	Cell House or New Industries	Cell House or New Industries	Cell House or New Industries	Cell House or New Industries
Capital Cost				
Solar Module (\$)	622,080.00	622,080.00	622,080.00	622,080.00
Inverter (\$)	80,000.00	80,000.00	80,000.00	80,000.00
Battery & Replacement (\$)	541,381.59	541,381.59	541,381.59	541,381.59
Charge Controller (\$)	25,000.00	25,000.00	25,000.00	25,000.00
Solar Module Rack (\$)	38,580.00	55,356.00	55,356.00	55,356.00
Power Conductor (\$)	26,140.83	26,476.35	26,476.35	26,476.35
Installation Cost (\$)	133,318.24	135,029.39	135,029.39	135,029.39
Yearly Cost				
Annual Capital (\$/yr)	141,218.16	143,135.29	143,135.29	143,135.29
Annual Operating (\$/yr)	2,824.36	2,862.71	2,862.71	2,862.71
Diesel Cost (\$/yr)	148,915.48	144,932.14	146,623.45	146,240.82
CO ₂ cost (\$/yr)	8,269.77	8,048.56	8,142.49	8,121.24
SO ₂ cost (\$/yr)	1,202.49	1,170.33	1,183.98	1,180.89
NO _x cost (\$/yr)	97,043.26	94,447.44	95,549.62	95,300.27
Total Yearly Cost (\$/yr)	399,473.52	394,596.47	397,497.54	396,841.21
Cost of Energy (\$/kWh)	0.4679	0.4622	0.4656	0.4649

As expected, the solar energy system with the greatest energy output has the smallest cost of energy, and the solar system with the least production has the most expensive energy cost. As seen in the Table 12, there is not a significant reduction in the cost of energy by tilting the panels. The increased cost of the racking system almost makes up for the extra energy produced by tilting the panels.

11.1.1.2 346 kW Hybrid Diesel-Solar Energy System with Battery Storage

The next cost analysis, shown in Table 13, is for the 346 kW rated hybrid system. The economy of scale principle indicates that the average energy cost should decrease with an increase in the size of the energy system. This is because the cost of an energy system does not increase linearly with the size of the system, but its energy production does. Also, a larger renewable energy system requires less diesel energy, resulting in a decrease in the cost of diesel fuel as well as the associated emissions penalties. Both of these factors dictate that the larger solar energy system should have a lower cost of energy than its smaller counterpart, but according to the economic analysis, seen in Table 12, there is a very slight increase in electricity cost for each system. The same unit cost is used for the panels and the racks in both economic analyses; however, this will probably not be the case for a purchase order of this magnitude. Also, the cost of the inverter and charge controllers are scaled linearly with their size, which may not be the case. These factors account for the absence of energy cost savings for the large system.

Table 13: Economic Analysis for a 346 kW rated Hybrid System

Hybrid Solar PV - Diesel Generator System with Battery Storage				
Solar Module Orientation	Horizontal	Tilted 28° Facing due South	Tilted 28° Facing 30° East of South	Tilted 28° Facing 45° West of South
Number of Modules	1728	1728	1728	1728
Rated Power (kW)	346.36	346.36	346.36	346.36
Percentage of Yearly Energy Demand	66.58%	73.00%	70.35%	70.95%
Required Area (ft ²)	46181.38	46181.38	46181.38	46181.38
Module Location	Cell House or New Industries	Cell House or New Industries	Cell House or New Industries	Cell House or New Industries
Capital Cost				
Solar Module (\$)	1,866,240.00	1,866,240.00	1,866,240.00	1,866,240.00
Inverter (\$)	160,000.00	160,000.00	160,000.00	160,000.00
Battery Bank & Replacement (\$)	541,381.59	541,381.59	541,381.59	541,381.59
Charge Controller (\$)	50,000.00	50,000.00	50,000.00	50,000.00
Solar Module Rack (\$)	115,740.00	166,068.00	166,068.00	166,068.00
Power Conductor (\$)	27,333.62	27,836.90	27,836.90	27,836.90
Installation Cost (\$)	276,069.52	281,152.65	281,152.65	281,152.65
Yearly Cost				
Annual Capital (\$/yr)	293,004.84	298,699.85	298,699.85	298,699.85
Annual Operating (\$/yr)	5,860.10	5,974.00	5,974.00	5,974.00
Diesel Cost (\$/yr)	64,008.46	51,713.03	56,786.97	56,041.61
CO ₂ cost (\$/yr)	3,554.60	2,871.80	3,153.57	3,112.18
SO ₂ cost (\$/yr)	516.87	417.58	458.55	452.54
NO _x cost (\$/yr)	41,712.18	33,699.66	37,006.18	36,520.45
Total Yearly Cost (\$/yr)	408,657.04	393,375.91	402,079.12	400,800.62
Cost of Energy (\$/kWh)	0.4799	0.4628	0.4730	0.4715

The energy cost for the large hybrid solar-diesel energy systems follows the same trend as the smaller energy system. The tilted, south facing panels are the least expensive, the tilted, 45° angled panels are second, the tilted, 30° angled panels are third and the horizontal panels are the most expensive. However, the cost differences are very small for the large solar system: the difference in the cost of energy between the four different module orientations is a maximum of \$0.017 per kWh of energy.

11.1.2 Grid-Tied Solar System

The alternative to having battery storage for a renewable energy system is to tie into the power grid. This removes the cost of a battery bank from a renewable energy system, as well as the cost of diesel fuel and its equivalent emissions costs. If Alcatraz Island is connected to the power grid, it can draw power from PG&E when needed and put power into the grid when excess renewable energy is available, eliminating entirely the need for diesel generators and energy storage. However, there is an additional cost of relaying the power grid and connecting it at both ends. Table 14 and Table 15 below demonstrate the economics of installing a solar energy system of the same size as those considered above in combination with an undersea cable connection.

11.1.2.1 115 kW Grid-Tied Solar Energy System

Table 14: Economic Analysis for a 115 kW Grid-Tied Solar System

Solar PV System with Grid Connection				
Panel Orientation	Horizontal	Tilted 28° Facing due South	Tilted 28° Facing 30° East of South	Tilted 28° Facing 45° West of South
Number Panels	576	576	576	576
Rated Power (kW)	115.45	115.45	115.45	115.45
Percentage of Yearly Energy Demand	22.25%	24.33%	23.45%	23.65%
Required Area (ft ²)	15393.79	15393.79	15393.79	15393.79
Module Location	Cell House or New Industries	Cell House or New Industries	Cell House or New Industries	Cell House or New Industries
Capital Cost				
Solar Module (\$)	622,080.00	622,080.00	622,080.00	622,080.00
Inverter (\$)	80,000.00	80,000.00	80,000.00	80,000.00
Charge Controller (\$)	25,000.00	25,000.00	25,000.00	25,000.00
Solar Module Rack (\$)	38,580.00	55,356.00	55,356.00	55,356.00
Power Conductor (\$)	26,140.83	26,476.35	26,476.35	26,476.35
Sea-Cable (\$)	2,500,000.00	2,500,000.00	2,500,000.00	2,500,000.00
Installation Cost (\$)	329,180.08	330,891.24	330,891.24	330,891.24
Yearly Cost				
Annual Capital (\$/yr)	360,656.73	362,573.86	362,573.86	362,573.86
Annual Operating (\$/yr)	7,213.13	7,251.48	7,251.48	7,251.48
Grid Energy (\$/yr)	93,345.06	90,848.18	91,908.35	91,668.50
Total Yearly Cost (\$/yr)	461,214.93	460,673.51	461,733.68	461,493.83
Cost of Energy (\$/kWh)	0.5399	0.5393	0.5405	0.5402

The cost of energy for a grid-tied solar system compared to a hybrid system is greater by \$0.07 per kWh in each scenario; however, the ranking from least to most expensive is slightly different. In this situation, the improved energy production of the non-true south facing, tilted panel orientation is not enough to compensate for the increased cost of the tilted racking system.

11.1.2.2 346 kW Grid-tied Solar Energy System

Table 15: Economic Analysis for a 346 kW Grid-Tied Solar Energy System

Solar PV System with Grid Connection				
Solar Module Orientation	Horizontal	Tilted 28° Facing due South	Tilted 28° Facing 30° East of South	Tilted 28° Facing 45° West of South
Number of Modules	1728	1728	1728	1728
Rated Power (kW)	346.36	346.36	346.36	346.36
Percentage of Yearly Energy Demand	66.58%	73.00%	70.35%	70.95%
Required Area (ft ²)	46181.38	46181.38	46181.38	46181.38
Module Location	Cell House or New Industries	Cell House or New Industries	Cell House or New Industries	Cell House or New Industries
Capital Cost				
Solar Module (\$)	1,866,240.00	1,866,240.00	1,866,240.00	1,866,240.00
Inverter (\$)	160,000.00	160,000.00	160,000.00	160,000.00
Charge Controller (\$)	50,000.00	50,000.00	50,000.00	50,000.00
Solar Module Rack (\$)	115,740.00	166,068.00	166,068.00	166,068.00
Power Conductor (\$)	27,333.62	27,836.90	27,836.90	27,836.90
Sea-Cable (\$)	2500000	2500000	2500000	2500000
Installation Cost (\$)	221,931.36	227,014.49	227,014.49	227,014.49
Yearly Cost				
Annual Capital (\$/yr)	486,980.36	492,675.37	492,675.37	492,675.37
Annual Operating (\$/yr)	9,739.61	9,853.51	9,853.51	9,853.51
Grid Energy (\$/yr)	39,906.07	32,415.41	35,595.92	34,876.37
Total Yearly Cost (\$/yr)	536,626.04	534,944.28	538,124.79	537,405.25
Cost of Energy (\$/kWh)	0.6298	0.6279	0.6316	0.6307

Similar to the results from the hybrid diesel-solar system analysis, it does not appear to be more economical to install a larger system, as would be expected for an energy system. In fact, the increase in the energy cost for all four panel configurations is roughly \$0.09 more for a 346 kW rated system than a 115 kW rated system. This is not an insignificant amount of money. Grid energy is cheaper than energy produced by solar panels or diesel generators, so it is not beneficial to build a larger renewable energy system in order to reduce the amount of energy purchased from the grid.

11.2 San Francisco Grid Power

The San Francisco energy grid was the original source of power for Alcatraz Island, and so is an obvious alternative to diesel generators for powering the island. The costs associated with reconnecting Alcatraz Island to the power grid in descending order are the installation of the cable on the sea floor, the cost of the actual cable, and then the cost to tie the cable into the power grid on the mainland and the island. After the cable has been installed, the energy consumed still has to be purchased. The normal rate of power from PG&E is \$0.14/kWh, and energy produced from a renewable source can be purchased at an additional cost of \$0.02/kWh. The cost of energy for an independent grid-tied system is seen in Table 16. For the purpose of consistency, this analysis assumes the same lifetime (20 years), interest (8%), and O&M (2%) as used elsewhere in the economic analysis. (The reasonableness of the 2% O&M has not been verified.) These assumptions also were used in the grid-tied solar system economics of the previous section.

Table 16: Economic Analysis for Stand Alone Grid-Tied Energy System

	Grid-tied System	
	Regular Energy	"Green" Energy
Energy Need (kWh/yr)	857,604.00	857,604.00
Component Cost		
Sea-Cable (\$)	810,000.00	810,000.00
Installation (\$)	1,200,000.00	1,200,000.00
Connection (\$)	500,000.00	500,000.00
Annual Cost		
Annual Capital (\$/yr)	255,649.04	255,649.04
Annual Operating (\$/yr)	5,112.98	5,112.98
Grid Power Cost (\$/yr)	120,064.56	137,216.64
Total Yearly Cost (\$/yr)	380,826.59	397,978.67
Cost of Energy (\$/kWh)	0.44	0.46

An undersea cable can be installed, and “green” energy can be purchased from PG&E for the entire year at nearly the same cost as installing a hybrid diesel-solar energy system.

11.3 Stand Alone Diesel Generator

The amount of money spent on diesel fuel each year is known, but that alone does not represent the production cost per kWh of energy each year. The cost of transportation of the fuel, operation of the generators and environmental effects all have to be accounted for in the economic analysis. For the sake of the analysis, it is assumed that the generators and the fuel transportation vessel are paid off. The results of the analysis can be seen in Table 17.

Table 17: Economic Analysis for Stand Alone Diesel Generator Energy System

	Stand Alone Diesel Generator
Energy Need (kWh/yr)	857,604.00
Annual Cost	
Diesel Cost (\$)	191,541.70
Transportation Cost (\$/yr)	1,080.00
Annual Operating (\$/yr)	3,852.43
CO ₂ cost (\$/yr)	10,636.90
SO ₂ cost (\$/yr)	1,546.70
NO _x cost (\$/yr)	124,821.34
Total Yearly Cost (\$/yr)	333,479.07
Cost of Energy (\$/kWh)	0.39

After factoring in transportation, operational costs and the cost of emissions from the diesel generators, it is still the least expensive energy system that is available on Alcatraz Island. This, however, assumes that the marine rate of diesel fuel is constant (\$3/gallon). In times of extremely volatile fuel prices, the CoE found for the stand-alone diesel generator and for the 115 kw PV system (which is quite dependent on diesel generation) will be different than the results shown in this analysis.

12 Electrical Considerations, Details, and Wiring Diagrams

12.1 Overview

The electrical considerations of the 115 kW and 346 kW horizontally mounted Sanyo PV-hybrid systems are presented in this section. The systems have been designed in accordance with the National Electrical Code. The cases treated can be used as guidelines for any system larger or smaller with similar electrical generation components. For each system, the daily load is assumed constant. In addition, each system incorporates both of the existing 210 kW gensets; however, it would not be difficult to modify the electrical configuration if the solar generator was augmented and a genset was removed or another completely different generator was added such as a wind or tidal turbine.

12.2 Solar PV Modules

Both of the systems are composed of the Sanyo HIP-200BA3 200 watt solar modules. The module specifications necessary for the electrical design are listed in Table 18.

Table 18: Design Specs for the Sanyo HIP-200BA3 Module.

Max Power Voltage, V_{pm} (V)	Max Power Current, I_{pm} (A)	Open Circuit Voltage, V_{oc} (V)	Short Circuit Current, I_{sc} (A)	Max system Voltage (V)	Series Fuse Rating (A)	Temperature Coefficient for P_{max} (%/°C)
55.8	3.59	68.7	3.83	600	15	-0.29

Virtually any panel could be selected. The main reason to employ a high efficiency PV module is to be able to place as many modules as possible in the space available. There is a space constraint if all of the panels are to be mounted on the New Industries Building. This building could accommodate the entire 115 kW array, but a 346 kW array would not fit in the space. For the analysis in this chapter, both the small and large arrays composed of Sanyo HIP

200BA3 solar PV modules are mounted horizontally on the roof of the Cell House with the balance of system components (inverter, charge controller, and battery bank) located in the Power House where the gensets currently reside. (An alternative location for the power electronics and batteries is the basement of the New Industries Building.) As shown in Figure 43 the Cell House is further away from the Power House than the New Industries Building; however, it can accommodate both array sizes and would have to be used if the NPS decides to purchase an array larger than about 150-200 kW.



Figure 43: A CAD depiction of Alcatraz Island from the North.¹¹¹

The main specification to consider when putting together a system of this size is the operating voltage of the module. In a small system it is common to size the array to operate at 120 volts or less; however, a 100 kW array composed of Sanyo panels with the above specifications and wired to 120 volts in series, would output a very large current (over 1000A). Power loss in a conductor is proportional to the operating current squared; thus, large currents are undesirable from a power loss perspective. The inverter selected has a maximum input voltage of 600VDC. Using a module with a larger output voltage

would reduce the number of modules required to be wired in series. With an open circuit voltage of 58.6VDC, eight Sanyo HIP 200BA3 modules can be safely wired in series for a maximum V_{OC} of 549.6VDC.

12.3 Inverter

SunEnergy is an Australian company that is one of the only companies that manufactures inverters for use in large scale off-grid installations. Its inverters come in units of 10 to 100 kVA and then in increments of 200 kVA from 200 to 1000 kVA. It was first thought to use a 100 kVA inverter with the Alcatraz system as the base, since it would be about the same size as the small solar array. An inverter this size would be sufficiently large enough to invert 100 kW from the array. However, one generator could only charge the batteries at half of its rated output; leading to extended run time which causes greater fuel consumption because of a lower operating efficiency at part load and greater maintenance cost due to extended hours of operation. In addition, a larger array or other renewable inputs could not be supplied to the site in the future without buying a larger inverter. Thus, it is decided to size the inverter to be at least large enough for one of the 210 kW gensets to charge the batteries close to its peak efficiency.

It is recommended that the solar/genset system be a dual diesel system with a 200 kVA inverter. PV and diesel generators have complementary characteristics. A PV system has a high capital cost, low operating costs and maintenance requirements, while a diesel system has low capital cost, but high operating costs and maintenance requirements. In addition, a diesel genset is available on demand, while the PV is dependent on the weather and time of day. Coupled together, PV and diesel gensets can provide a more reliable and cost effective system than either PV or diesel alone. The bidirectional inverter will work with the genset pair to provide optimal loading on the diesel and during peak loads

can support the diesel to provide power of virtually the sum of the diesel and inverter ratings as shown in Figure 44.

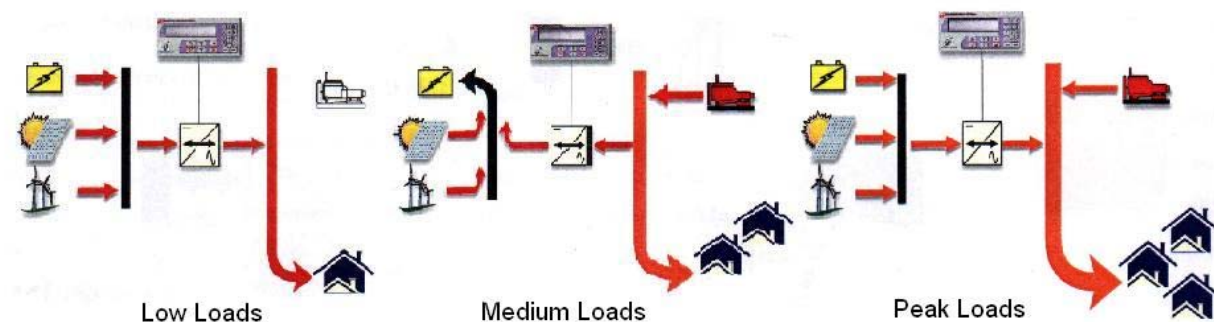

Figure 44: Generalized diagram of renewable/genset interaction for varying electric load.

With a 200 kW PV array, a 200 kVA inverter, and a 210 kW diesel genset, it will be possible to provide peak loads up about 410 kVA. When there are low building loads, the inverter will shut the diesel off and the battery and renewable generation will provide the entire building load. When there are intermediate loads, the diesel will provide the entire building load and aid the renewable generation to provide optimal charging to the batteries. The main advantages to this system are:

1. The gensets are always operating near full load; thus reducing fuel, operating, and maintenance costs.
2. The diesel can be completely turned off.
3. Both diesels are run in an alternate manner.

In general, there are three primary operational modes for this system. When the battery is close to full charge and there is relatively low power requirement, the diesel generator will be turned off and the all of the power will be drawn from the battery bank and solar generator. When the battery bank is at a low state of charge and there are building medium sized building loads, the solar generator will charge the battery bank and the diesel generator will be operating near full capacity with part of the power going to the building load and the rest charging the battery bank. During periods of peak building load, which should be limited to

a few minutes for a properly designed system, the solar generator, the battery bank, and the genset supply power to the building load.

Figures 45 and 46 can help further illustrate what a typical power producing/consuming five day period may look like at Alcatraz. For example, there is a battery bank with 2500 kWh of storage, a 100 kW PV array, a 400 kVA inverter, and two 210 kW gensets. The solar resource is a generic representation of an average sunny day during the spring in San Francisco. The load is representative of the power draw averages for day and night time hours as outlined in Chapter 3. (Note that energy load is plotted negative in Figure 45 – increasing downward.) The set point for the battery bank is set to 55% state of charge, SOC, meaning that at least one generator will turn on automatically when the battery bank falls below 55% SOC.

At the beginning of the first day the SOC of the battery bank is hovering just above the set point. There is no solar contribution and the building load is drawing its night time average of 41 kW. At about 2:00 am one of the 210 kW gensets turns on for an hour taper charging the battery to a state above the set point. As the day goes on, the solar contribution ramps up, but so does the building load; thus, there is still need for periodic trickle charging of the battery bank. At about midnight near the end of the first day, both diesel generators turn on and bulk charge the battery bank back to full SOC, while powering the building load simultaneously. In this particular model, if 24 hours goes by and the battery bank has not been charged to full capacity then a bulk charge initiates; the second diesel generator turns on at full capacity, the battery is charged back to 100% SOC, and the cycle repeats itself.

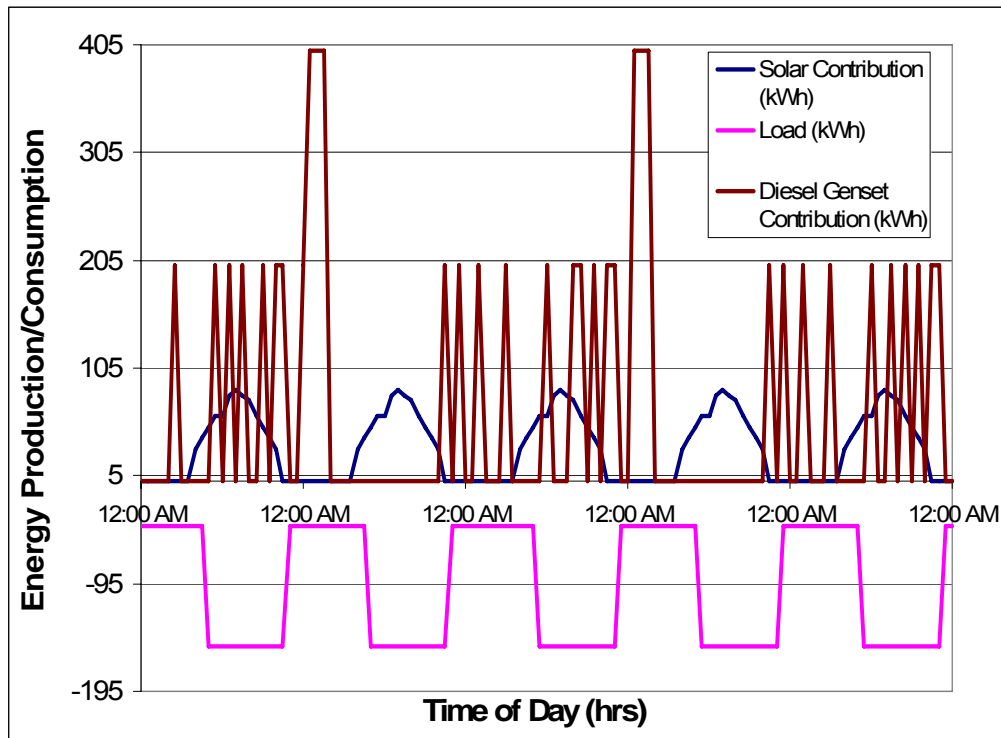

Figure 45: A model representation of a typical 5 day charging/discharging schedule for Alcatraz.

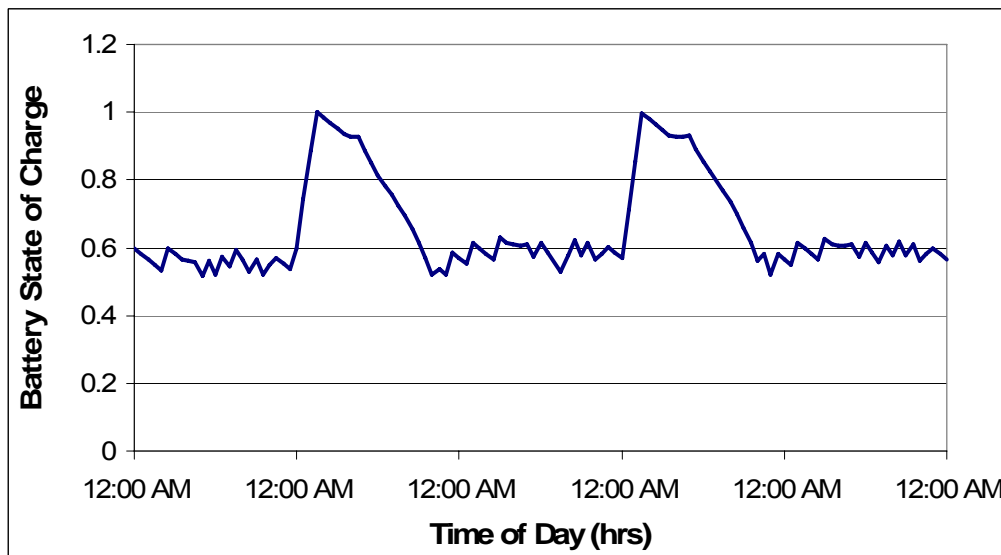

Figure 46: Battery Bank SOC corresponding to the charging/discharging cycle in Figure 45.

It should be noted that the length of time the generator will run per day will decrease as the solar array is augmented. If there is a large enough solar array there will be no need for as many periodic trickle charges throughout the day; however, there should always be a scheduled bulk charge every 2-5 days to ensure proper battery health. The charging/discharging schedule will also change with weather and size of battery bank. As mentioned before, the addition of a solar generator has allowed the diesel genset pair to run for a fraction of the day at full capacity, instead of all day long at a fraction of its capacity. Increasing the size of this array will further decrease the run time of the gensets.

A 200 kVA rated inverter could be used for a 115 kW rated system; however, the second genset would be strictly used to power building loads while the first genset is charging the battery. A 400 kVA rated inverter would be employed for the 346 kW rated system to provide an adequate inverting capacity for periods of high solar resource, and this inverter would allow both gensets to aid in the bulk charge. In addition to providing a factor of safety, a 200 kVA inverter would leave room for additional solar PV modules to be added to the 100 kW system and allow the 210 kW generator to run at almost full capacity. The 200 kVA rated inverter is quoted at \$75,000 plus the cost of shipping the unit from the east coast of the US, and for the 400 kVA inverter, cost nearly doubles. In addition to the inverter, a solar charge controller is required which costs an additional \$20,000 per 200kVA, and the brains behind the dual diesel control are expected to add another approximately \$10,000 to the overall system cost. The economic analysis of Chapter 11 assumes a 200 kVA inverter for the 115 kw PV system and power electronics costs of \$80K+\$25K (the same total as here), whereas for the 346 kw system, the 400 kVA inverter with power electronics costs of \$160K+\$50 (the same total as here) are assumed.

12.4 Battery Bank

The battery bank is the next item to be sized and priced. Generally the energy storage for an off-grid PV system is sized to provide a number of days of autonomy. This corresponds to the maximum number of days a site would have to run off of battery power due to lack of sun exposure, which is 1.09 days for San Francisco in July. Since average energy consumption at Alcatraz is 2350 kWh, this means at least 2,500 kWh of battery storage is needed for the diesel generator not to be used in July. It is common practice to size a battery bank twice or more times the adjusted storage requirement, not including power losses in the line and inefficiency in the charging/discharging procedure. These safety factors lead to an extremely large and expensive battery storage system. Both due to the large diesel generator already in place and the high cost of batteries, the normal rules of thumb for sizing a battery bank have been overlooked. The battery bank has been sized for 2500 kWh total capacity, about ½ of which can be used. Although the diesel generator will have to be turned on every day, the inverter along with the PV array will help to decrease the generator run time from all day to about 7-14 hours per day depending on the size of the installed PV array.

The estimated cost of a battery bank this size is between \$300,000 and \$500,000 depending on the battery cell chosen. The low end of the spectrum corresponds to a large battery with a high voltage but equivalent capacity. For example, a SunEnergy 200 kVA inverter is designed to charge a 360V battery bank. The two flooded lead-acid cells that are being considered are the C&D CPV-2500 rated at 2 volts per cell and 2041 amp-hours, and the Surrette 8-CS-25PS rated at 8 volts per cell and 1156 amp-hours. A 2500 kWh battery bank at 360V would need to be composed of 4 strings of 180 C&D cells, while the same size battery bank would need to be composed of 8 strings of 45 Surrette cells. Clearly fewer cells would have to be purchased if Surrette is used; consequently, this battery

bank would be cheaper by about \$200,000. However, a couple of maintenance considerations do not make this an easy choice. First, each Surette cell weighs about 600 lbs, in comparison to about 100 lbs for the C&D cell. After speaking with various institutions that maintain large battery banks, it became clear that it is far easier to maintain a battery bank composed of small cells.¹¹² Not only does the 8 volt battery charge and discharge in a more non-uniform manner than a 2 volt battery, if it has to be replaced or serviced, a forklift must be employed, whereas maintenance technicians can handle the smaller battery alone. Because of these reasons and numerous case studies of proven reliability for the C&D battery, it is recommended for this application; however, the large price difference may also affect the final choice. The economic analysis of Chapter 11 assumes the \$300,000 battery bank cost.

It is important to recognize the charging and discharging considerations when employing a small battery bank for a relatively large rate of energy consumption. The battery bank will complete a cycle every 1 to 5 days. Especially during periods of low solar insolation, the genset will have to run for a good portion of the day to fully charge the batteries and help to limit capacity loss. Basically, instead of the diesel generator running all day long at half load or less, the genset will be running for 7 to 14 hours per day at full load, which is much more efficient in terms of fuel consumption and reduces engine maintenance.

Following the example of the solar PV hybrid project at Grasmere, Idaho, there are a couple of operating parameters that should be noted.¹¹³ The discharge termination voltage should be limited to about 1.98 vpc (volts per cell). This corresponds to a depth of discharge of about 55%. The recharge termination voltage and bulk charge voltage should be about 2.55 vpc. It is found that the battery maintains its capacity best with a bulk charge every 5th cycle for 5 to 6 hrs.¹¹⁴ The Grasmere project also proved that unacceptable capacity loss resulted in setting the taper charge interval every 20 cycles (about 30 days).¹¹⁵

In order to prevent excessive gassing the current going into the battery bank should be limited to a rate of about C/10.¹¹⁶ Each battery has nominally 2 vpc and 2041 amp-hours of capacity, corresponding to a total voltage and capacity of 360 VDC and 8164 amp-hours. A C/10 charging rate corresponds to 8164 amp-hours/10 hrs, or about 816 amps. This means that the input current from either the solar or diesel generator should be limited to about 800 amps to ensure safe charging. The battery bank at Grasmere has run for 12 years of operation without replacement.¹¹⁷ The best a PV system designer can really hope for is to only have to replace the battery bank once within the 20 years lifetime of the entire system. With proper storage, charging and discharging precautions, it has been shown that this is possible.

12.5 The NEC

The 2005 National Electric Code, or NEC, has been consulted to design the system for safety and reliability. The NEC is published about every three years by the National Fire Protection Association. The NEC is a collection of articles that apply electrical safety and efficient utilization considerations to a slew of topics such as: wiring methods and materials, and wiring protection. Article 690 is specifically written about solar PV systems. To protect both technicians and end users, the NEC specifies the size, type and location of fuses, conductors, and breakers to be used. Other considerations such as wire losses, types of wire housing, and wire materials are also taken into consideration.

12.5.1 Cables and Over-current Device Sizing

Calculations for conductor sizes and over-current device ratings are based on the requirements of both the NEC and on UL Standard 1703, which provides installation instructions for PV products. Wire ampacity data and temperature derating factors are found in Tables 310.16 and 310.17 in the 2005 NEC.¹¹⁸ The

115 kW example PV hybrid wiring diagrams are shown in Figures 47 through 51. The optimally sized subarray for the 115 kW system is shown in Figure 47. It is composed of 6 sets of 96 panels that are wired together with 8 panels in series and 12 strings in parallel. Notice that every other parallel string is ganged with the string adjacent to it, so effectively there are only six strings in parallel. This is allowed by the NEC if the conductors and over-current protection devices are sized to protect the circuit. Since the short circuit current of one of the Sanyo HIPBA200 modules is only 3.83A, it is definitely more economical to combine two of them and use 6 larger fuses rather than 12 smaller fuses. The actual wiring requirements are presented below.

There are six basic steps to sizing a conductor:

1. Article 690-8a states that the maximum current should be the sum of parallel module rated short circuit currents multiplied by 125%.¹¹⁹ This is sometimes referred to as the continuous current. This 125% correction factor is required because the short-circuit current of a module is referenced at a peak irradiance of 1,000 W/m²; however, the intensity of the sun at solar noon can exceed 1,000 W/m².¹²⁰ Each module string circuit conductor is rated at 125% of the individual module I_{sc} . Each sub-array source circuit conductor should be rated at 125% of the sum of the individual short circuit currents in the sub-array. The battery input circuit should be rated the same as the source circuit rating, since there are two conductors. If there was only one conductor, then each battery input conductor must be rated at 125% of the short-circuit current from both sub-arrays. The inverter input circuit should be rated to handle the continuous inverter input current, when the inverter is producing rated power at the lowest possible input voltage.¹²¹ For example, in Figure 4, the inverter is rated to 200 kVA, the lowest operating voltage of the battery bank is about 330 volts, and the inverter efficiency is about 90%. The

input current is then: $I = \frac{200,000 \text{ VA}}{(330 \text{ volts}) * (0.9)} = 673 \text{ A}$. The inverter output

conductor should have a rating equal to the continuous current output rating; however, it is recommended that this conductor be oversized to allow for the surge capability of the inverter.

2. Article 690-8b states that the conductor and over-current device must be rated at 125% of the current determined in step 1, which is to prevent over-current devices from operating at more than 80% of their rating. However, circuits containing over-current devices that are listed for continuous operation at 100% of their rating are permitted to be employed at the full rating.¹²² All of the breakers selected have 100% duty ratings, so the second 125% correction factor is only applied to the conductors.
3. Cables should have an ampacity at 30°C of 125% of the current determined in step 1 in order to guarantee proper operation of attached over-current devices.¹²³
4. A cable size and insulation temperature rating must be selected from the NEC Ampacity Tables 310-16 and 310-17. The size of the cable is determined from the 75 °C insulation level; then the cable is derated for temperature, conduit fill, and other provisions. The derated ampacity must be larger than the ampacity determined in step 1. If the ampacity isn't larger; then a larger cable or higher insulation temperature must be selected.¹²⁴
5. The derated ampacity of the cable in step 4 must be greater than or equal to the over-current device rating determined in step 2. If this is not the case; then a larger gauge conductor must be selected.

6. Stated in article 110-3b: cables must be compatible with the temperature ratings of terminals on over-current protection devices. Most over-current devices have terminals rated to 60 or 75 °C. If a cable with 90 °C insulation has been selected, the 30°C ampacity of a of the same size cable with 60 °C or 75 °C insulation must have a derated ampacity larger than that determined in step 1.¹²⁵

The 115 kW system in Figures 47 through 50 is used as an example. The charging circuit, or subarray circuit is the circuit connecting each subarray to the charge controllers. As mentioned before, each module has a short circuit current of 3.83A. All 12 strings combined together create a total short circuit current of 45.96A. The conductor size and protection are determined as follows.

The continuous current is found in accordance with article 690-8a.

$$I_{sc} = (6 \text{ strings}) * \frac{7.66 \text{ A}}{\text{string}} * 125\% = 57.45 \text{ A}$$

The breaker is sized to operate at 80% of rated capacity in accordance with 690-8b. Thus, its current is 1.25 x 57.45, or 71.8A.

From Table 310-16, a 1/0 AWG USE-2 copper wire with 90 °C insulation is rated to 170A. Now a temperature derating must be applied. The wire is in conduit, and it is assumed the wire will be operating at the maximum expected cell temperature of about 70 °C. The temperature derating factor for copper conductors in conduit with 90°C insulation at 70 °C is 0.58.¹²⁶ Shown below, the derated ampacity of the conductor is 98.6A, which is greater than the ampacity determined in step 1.

$$I = (170 \text{ amps}) * (0.58) = 98.6 \text{ amps} .$$

Standard ratings for over-current devices are shown in article 240-6 of the NEC. It is possible to protect a cable with a derated ampacity of 98.6 amps with an 80

amp over-current device and still have the over-current device larger than the required 71.8 amps determined in step 2.

Presently there are no over-current devices that have terminals listed for 90°C insulation; most are listed for 75 or 60°C insulation. The selected over-current device has terminals that are rated at 75°C insulation, so the cable derated ampacity must be checked again at 75°C. The derated ampacity of a 1/0 AWG conductor with 75°C insulation is 150 amps x 0.58, or 87 amps, which is larger than the required ampacity found in step 1 and is larger than the selected 80 amp over-current device. All of the conductors in this installation have been sized according to the methods outlined above.

In addition to conductor and over-current protection sizing, there are many other issues that the NEC addresses. Some of the additional requirements and codes are outlined below; however, the serious system designer should become familiar with the entire NEC, not limited to the information found in this report.

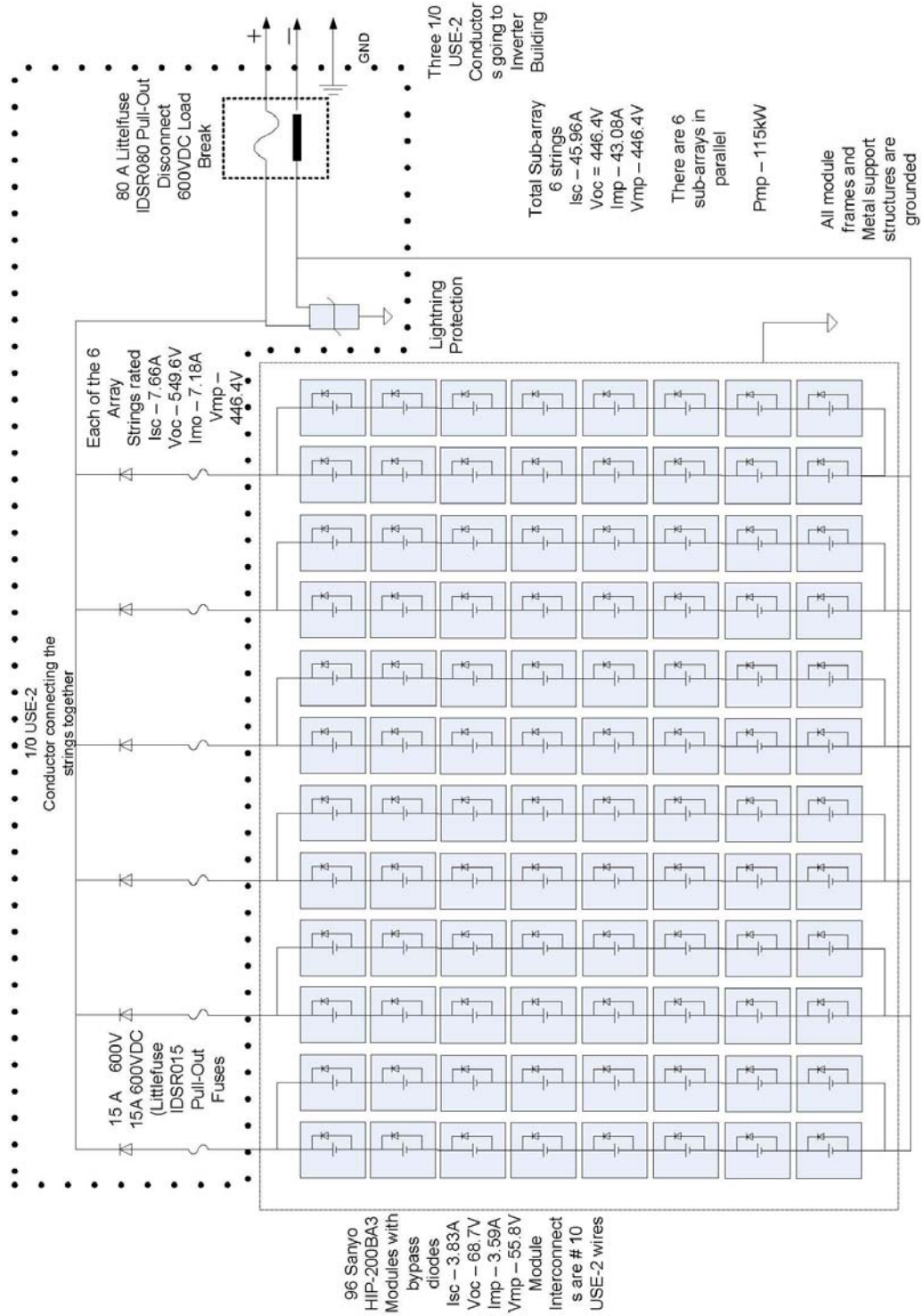

Figure 47: Sub-array for the 115 kW system.

12.5.2 Battery Bank Wiring Considerations

A short circuit condition in a battery bank can be a severe situation, with a single 6 volt, 220 amp-hour battery being able to produce short-circuit currents as high as 8,000 amps, which can generate temperatures and magnetic forces that can destroy underrated over-current devices.¹²⁷ The interrupt capability of an over-current device is specified as the amperes interrupt rating, or AIR, and reach 120,000 amps in some dc rated fuses. A current limiting fuse must be used in a battery circuit that has breakers that have a low AIR rating.¹²⁸ As shown below in Figure 48, two 175 amp, Littelfuse, current limiting fuses protect each string of the battery bank.

One other unique design aspect of such a large system is the fact that the system voltage is so large. Most DC over-current devices are rated to a maximum voltage of 125VDC. All of the current system components have an operating voltage far higher than 125VDC; thus, special over-current devices have been selected. Both the Littelfuse IDSR series fuses and the Ferraz-Shawmut A4BQ series fuses are rated to 600VDC and provide current ratings within the specifications of this design. The A4BQ series fuses are slightly more expensive than the Littelfuse models at equal current ratings; however, the maximum current that the Littelfuse IDSR model can handle is 600A. Thus, the Ferraz-Shawmut A4BQ fuses are only selected for applications with currents larger than 600A.

12.5.3 DC Grounding

For systems over 50 volts, which is the open-circuit voltage multiplied by a temperature coefficient found in Table 690.7 of the NEC, the DC side of the system must be grounded, which is usually the negative conductor. In addition,

all systems regardless of voltage must have equipment grounding conductors to ground exposed metal parts of non-current carrying conductors.¹²⁹ In order to reduce fire hazards, roof mounted PV systems must include ground fault protection devices, as outlined in Article 690.5 of the NEC.¹³⁰ The ground fault protection devices are shown connected to each sub-array circuit above in Figures 47.

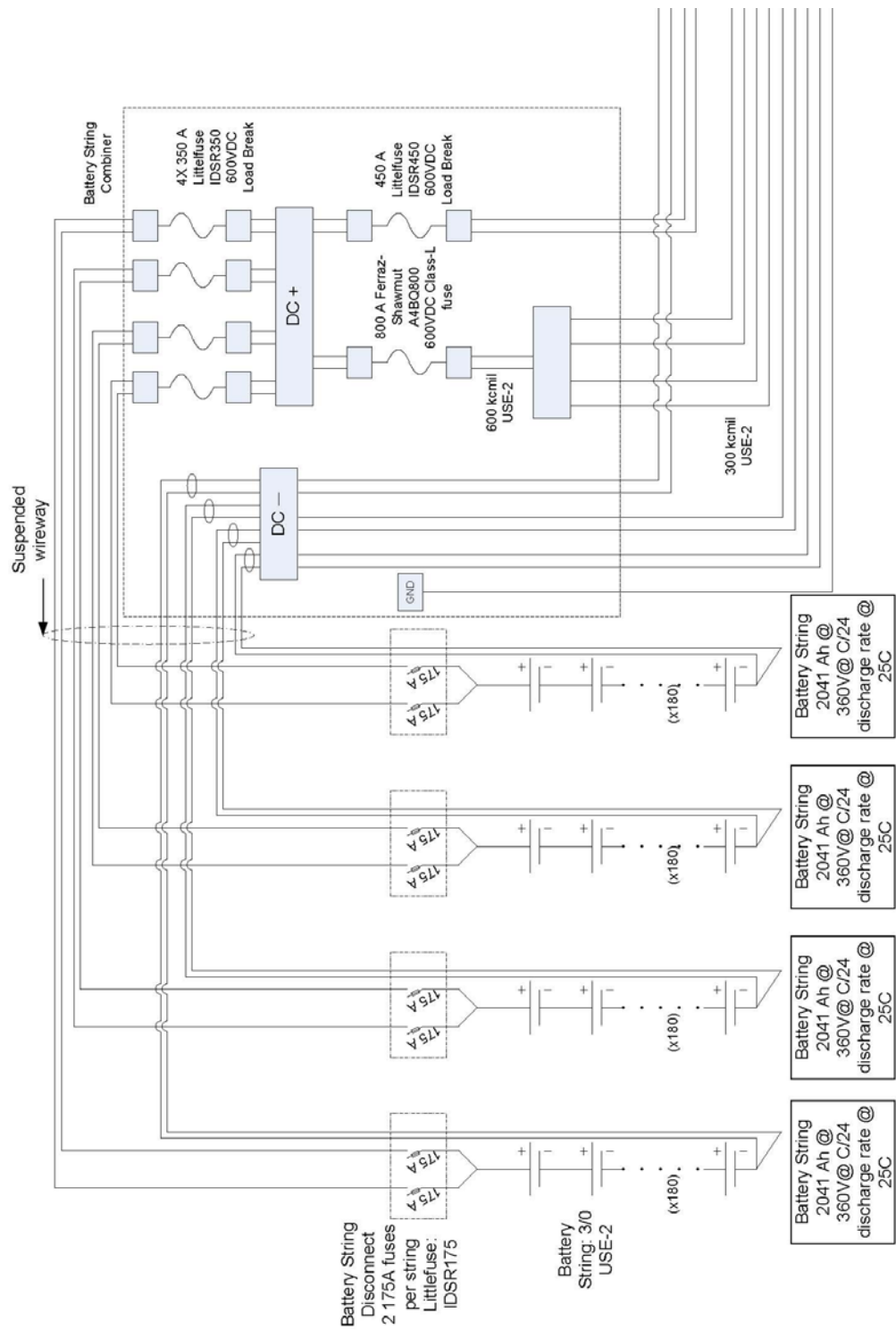

Figure 48: Battery bank wiring for the 115 kW array.

12.5.4 Generators

The AC side of the 115 kW system is shown in Figures 49, 50, and 51. The NEC requires that the conductors between the generator and the first installed field device be rated at 115% of the nameplate rating. One of the currently installed gensets is rated to 210kW; however, the selected inverter for the 115 kW system is only rated to 200kVA. The operating voltage of the generator is 208VAC. Thus the maximum current per phase of the generator will be:

$$I_{\text{Generator/phase}} = \frac{200,000 \text{ VA}}{(208 \text{ VAC}) * \sqrt{3}} * 1.15 = 638 \text{ A} .$$

Thus, 500kcmil THHN conductors are selected for most of the AC circuitry. THHN rated conductors are used for most of the AC wiring; instead of USE-2 conductor cable. Both of these conductors are rated for operation up to 90 °C; however, the USE-2 is to be operated at continuous current in wet conditions, where THHN cable is not. THHN conductor cable is slightly less expensive than the USE-2 for the same gauge.

12.5.5 Voltage Drop Considerations

All of the other conductors and over-current devices are sized similarly to the methods above. However, the NEC also requires that the total voltage drop in feeder and branch circuits must be less than 3%. If the panels are mounted on the Cell House roof, the PV source circuits could be located as far as 250 feet away from the SunEnergy Solar Regulators. In order to keep voltage drop within the limit, these conductors should be oversized. Nominal ohmic resistances per 1,000 feet are found for each wire size in Chapter 9 of the NEC, which should be used to calculate voltage drop. Note that voltage drop must be calculated for the entire length of the wire (both positive and negative conductors); thus if a source

circuit is 22 feet away from the charge controller, the circuit length is 44 feet.

Percent voltage drop can be calculated from the equation below:

$$\% VD = 100 * \frac{I}{V_s} R \frac{2d}{1,000} \quad 131$$

where,

- %VD is the percentage voltage drop
- V_s is the source voltage in volts
- I is the load current in amps
- R is the wire resistance in ohms per 1,000 feet
- d is the one way circuit distance in feet.

Note that the above equation assumes that the load voltage is essentially equal to the source voltage.

1. Each sub-array is fed through two 3 pole fusable disconnects and eventually ganged after all the relays at the terminal block prior to the 450A fuse. Actual wiring is not shown for simplicity.

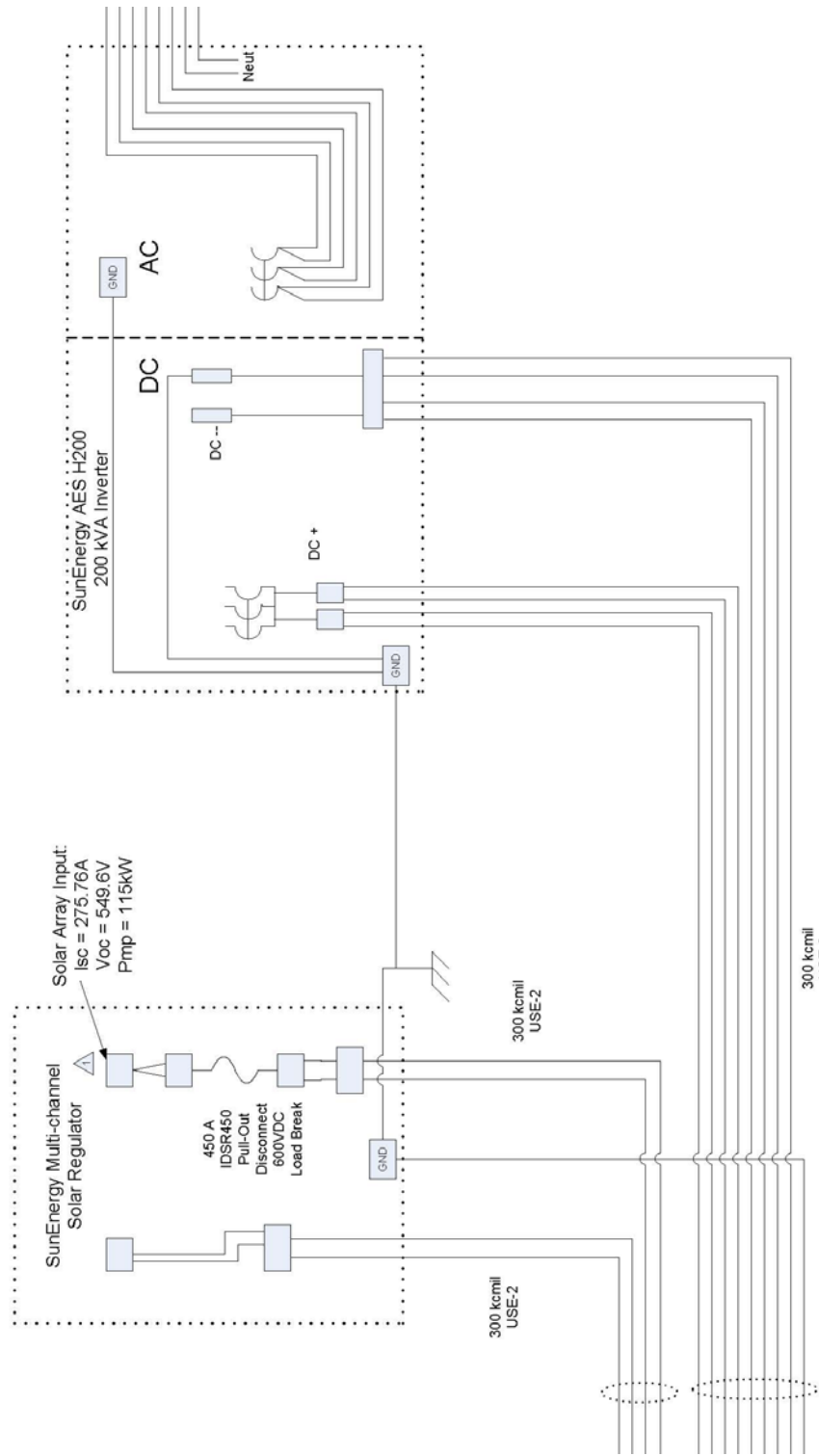

Figure 49: DC to AC wiring diagram for the 115 kW system.

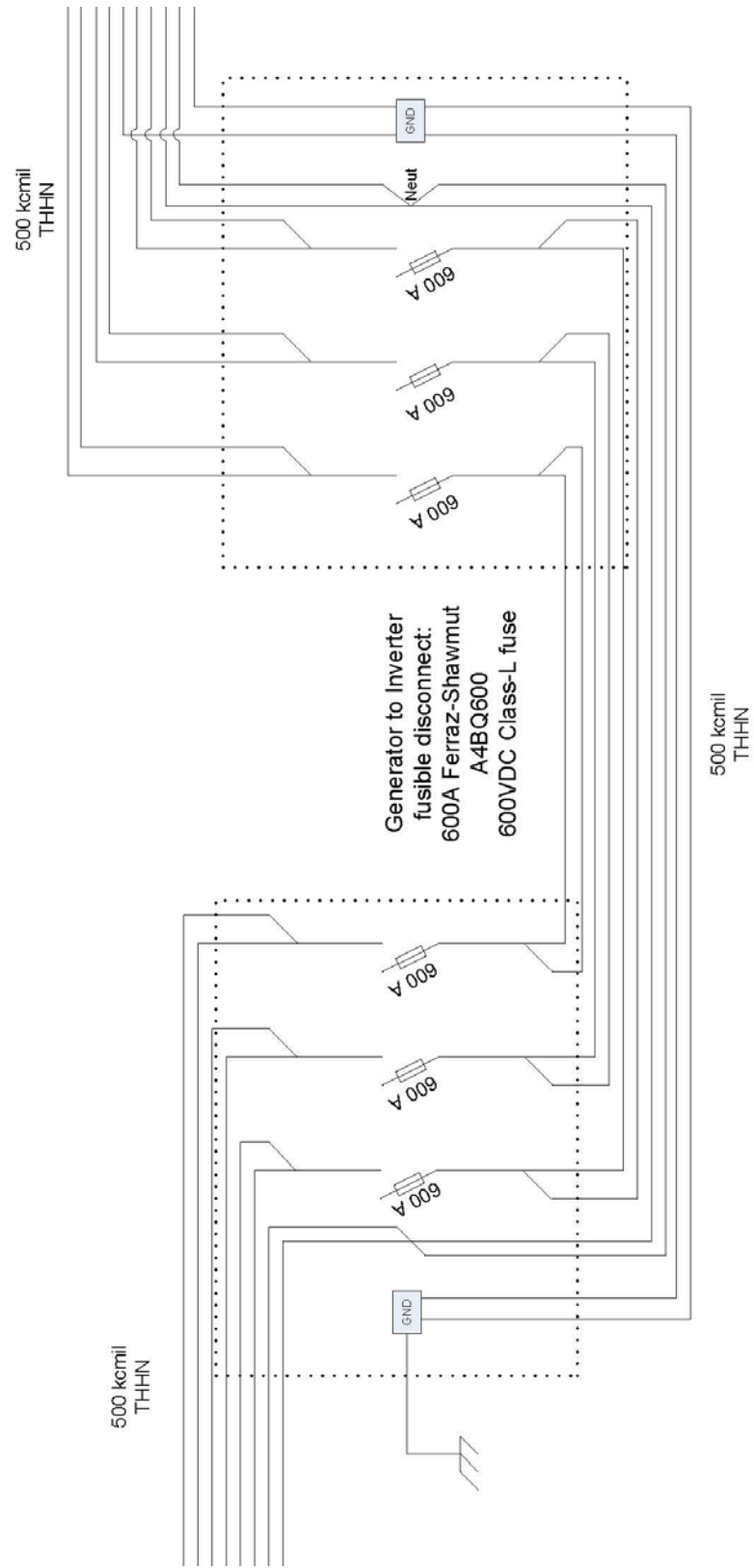

Figure 50: Inverter to Generator Wiring Diagram for the 115 kW system.

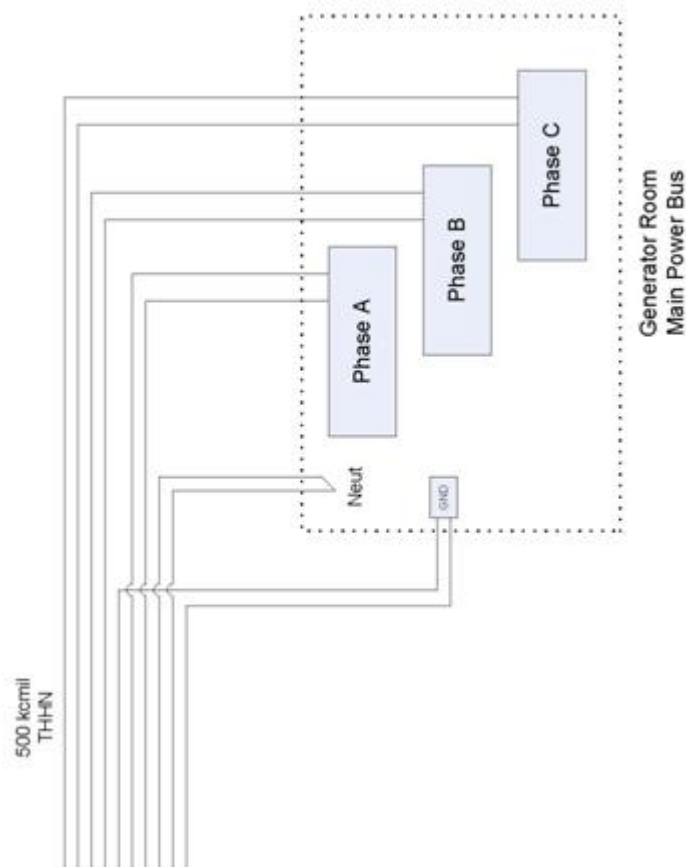

Figure 51: Main Generator Bus Diagram for the 115 kW system.

12.6 346 kW PV hybrid System

As mentioned before, a 346 kW system has also been detailed. All of the same NEC guidelines have been employed when selecting the conductors, over-current devices and ground fault protection. The actual wiring is explained and shown in Appendix H.

13 Conclusions and Recommendations

The purpose of this project is to determine a renewable energy system for the Golden Gate National Recreation Area at Alcatraz Island. First, the current energy load is assessed and possible energy consumption reduction methods are explored. Next, the renewable resources in the San Francisco Bay are identified and analyzed. The possibility of a pumped storage energy system using the water tower located on the island is also considered. Once the optimal renewable resource is identified, an energy system is designed, and an economic analysis is performed on the system.

The current average energy consumption on Alcatraz Island is 2350 kWh per day; this number could be reduced by 42% by replacing all of the incandescent and halogen light bulbs with high efficiency compact fluorescent lights. The three renewable resources identified in the area are solar, wind and tidal. A full small wind turbine array located on the roof of the Cell House could only produce 3% of the energy demand for the entire year. Likewise, the tidal resource only has a maximum power density of 0.4 kW/m², which is not large enough to justify a tidal turbine installation. Unless alternative data can be obtained regarding either of these resources, neither are viable considerations for renewable energy systems at Alcatraz Island. The best renewable energy resource is solar energy, which can produce between 20% and 70% of the energy demand for the year, depending on the number of panels and their orientation.

The solar energy system can range in size from 115 kW to 346 kW rated power. Although a larger rated system could fit on the combined roofs of the Cell House and New Industries buildings, it is not recommended unless the island is reconnected to the power grid in San Francisco. A solar system larger than 346 kW rated will produce more energy than can be consumed or stored on the island, especially in the summer, so the excess energy will go to waste. Special

considerations for a solar energy system are the panel tilt angle and orientation relative to the building long side. South facing tilted panels can produce 9.3% more energy per year than horizontal (flat) panels; however, neither building of interest faces south. The result of orienting tilted solar modules in line with the New Industries Building is a 5.3% increase in power output over a horizontal PV system and an increase of 6.3% by orienting the panels in line with the Cell House Building. Titled solar module racks are more expensive than horizontal racks, so this is considered in the economic analysis. The final component of the renewable energy system is the backup energy system. The options are to continue using the diesel generators, already located on the island, or to reconnect to the power grid in San Francisco. There is a significant capital investment to re-lay and reconnect the undersea cable that would bring power to the island, but grid power is relatively inexpensive to purchase once installed. Although there is no capital cost associated with the diesel generators, the operating cost to purchase fuel and maintain the generators is considerably greater than grid energy.

A cost comparison for each system explored in this report is shown in Table 19 below. The cost is separated into the initial capital investment, the annualized capital cost, the annual operating cost and the resulting cost of electricity. The price range shown for each combination solar energy system is the maximum and minimum price based on the tilt angle and orientation of the panels. There is not a significant difference in the price between the small and large hybrid diesel solar energy systems. Grid-tied solar energy is considerably more expensive than hybrid diesel solar energy, with a large increase in price between the small and large solar system. Unaccompanied, grid-tied energy is comparable with hybrid diesel solar energy, and diesel generator energy is the least expensive overall – at least when diesel fuel is \$3/gallon as assumed in this study.

Table 19: Cost Breakdown of the Six Prospective Energy Systems

Energy System Configuration & Size	Capital Investment (\$)	Annualized Capital Cost (\$/yr)	Annual Operating Cost (\$/yr)	Cost of Electricity (\$/kWh)
Hybrid Diesel Solar 115 kW	1,521,069 - 1,539,892	143,000 - 144,919	251,496 - 258,291	0.46 - 0.47
Hybrid Diesel Solar 346 kW	3,144,832 - 3,200,746	296,463 - 302,158	94,745 - 115,128	0.46- 0.48
Grid-tied Solar 115 kW	3,675,549 - 3,694,372	362,440 - 364,357	98,135 - 100,593	0.54
Grid-tied Solar 346 kW	5,049,312 - 5,105,227	490,438 - 496,133	42,338 - 49,714	0.63
Stand Alone Grid Energy	2,510,000	255,649	125,178 - 142,330	0.44 - 0.46
Stand Alone Diesel Generators	N/A	N/A	333,478	0.39

On a purely economic basis, diesel power generation is the best energy source and on a practicality scale, grid energy is likely the most reliable and simplest to maintain. This, however, does not make them the best energy solutions for the island. A solar energy installation at Alcatraz Island could be an opportunity to educate thousands of people that visit the park each day about clean, renewable energy. It will also reduce the amount of diesel fuel that is consumed in the Bay area each day, which could be beneficial with the prevailing fuel shortage and volatility of cost. The optimal system is one that minimizes energy cost, reduces diesel fuel consumption and incorporates renewable energy, which is true for both hybrid diesel-solar energy systems. The larger system may be more economical if there is an increase in the cost of diesel fuel, but either system is recommended for application at Alcatraz Island.

These are not the only solar PV configuration possibilities for Alcatraz Island. Any array that is the same size or smaller than the largest possible systems defined in Table 19 could be implemented on the island. The largest possible horizontal solar array that could fit onto the roof of the New Industries building is

rated at 153 kW, assuming Sanyo modules, and 211 kW assuming SunPower modules. The largest south facing, tilted solar arrays that will fit onto the New Industries Building roof are rated at 128 kW and 181 kW, respectively, for the Sanyo and SunPower modules. The Cell House roof can accommodate horizontal solar arrays up to a maximum rating of 346 kW using the Sanyo modules and 393 kW using the SunPower modules, which will produce more solar electricity than the demand in July. This value is reduced to 307 kW for the Sanyo modules and to 302 for the SunPower modules by tilting the modules and facing them south, since this curtails the number of modules that can be placed on the roof. The 115-120 kW rated system explored in this study will fit onto either of the buildings in any of the three orientations considered. The NPS should select the energy system that is the most practical for its operation and in line with its objectives and budget.

END NOTES

- ¹ San Francisco Bay
- ² Alcatraz Island
- ³ Legends of Alcatraz
- ⁴ National Park Service, The Industries
- ⁵ Alcatraz
- ⁶ Alcatraz Island Diagram
- ⁷ Butterworth, personal interview
- ⁸ Clark
- ⁹ National
- ¹⁰ Malte (1)
- ¹¹ Butterworth
- ¹² Caterpillar
- ¹³ Malte (1)
- ¹⁴ Malte (1)
- ¹⁵ Electrical Energy Transmission
- ¹⁶ Clark
- ¹⁷ Perez
- ¹⁸ McAllister
- ¹⁹ Lawrence
- ²⁰ Castellini
- ²¹ DOE, Laurence Berkeley, McAllister, Perez
- ²² Department of Energy (1)
- ²³ Megaman
- ²⁴ Energy Star
- ²⁵ Castellini
- ²⁶ Walker
- ²⁷ National Solar Resource Data Base
- ²⁸ Microclimate
- ²⁹ Malte
- ³⁰ National Solar Resource Data Base
- ³¹ SunPower
- ³² Wilcox
- ³³ Sanyo
- ³⁴ Brown
- ³⁵ Renewable Energy
- ³⁶ Renewable Energy
- ³⁷ Renewable Energy

- ³⁸ Twindell, pg 291
- ³⁹ Kaper
- ⁴⁰ Renewable Devices
- ⁴¹ Renewable Devices
- ⁴² Abundant Renewable Energy
- ⁴³ Abundant Renewable Energy
- ⁴⁴ Abundant Renewable Energy
- ⁴⁵ Bergey Windpower Co.
- ⁴⁶ Bergey Windpower Co.
- ⁴⁷ Bergey Windpower Co.
- ⁴⁸ Windside Turbines
- ⁴⁹ Windside Turbines
- ⁵⁰ PacWind, Inc.
- ⁵¹ Clint
- ⁵² PacWind, Inc.
- ⁵³ Savonius Wind Turbine
- ⁵⁴ Twindell, pg 269
- ⁵⁵ After Gutenberg, American Wind Energy Association
- ⁵⁶ Alcatraz
- ⁵⁷ Polagye
- ⁵⁸ Tide
- ⁵⁹ NOAA
- ⁶⁰ Malte (2)
- ⁶¹ USGS
- ⁶² USGS
- ⁶³ Verdant
- ⁶⁴ Verdant
- ⁶⁵ GCK Technologies
- ⁶⁶ GCK Technologies
- ⁶⁷ Malte (2)
- ⁶⁸ Polagye
- ⁶⁹ Previsic
- ⁷⁰ Previsic
- ⁷¹ Polagye
- ⁷² Pacific Gas & Electric
- ⁷³ Clark
- ⁷⁴ Fackler
- ⁷⁵ Castellini

- ⁷⁶ Google
- ⁷⁷ Johnson
- ⁷⁸ Plant-Based Corrosion Inhibitors
- ⁷⁹ ECONOMIC STUDY
- ⁸⁰ Technical Information
- ⁸¹ Cathodic protection
- ⁸² Si-COAT: Technology that Sticks
- ⁸³ Si-COAT 579
- ⁸⁴ Roy
- ⁸⁵ Si-COAT: Technology that Sticks
- ⁸⁶ Renewable Energy
- ⁸⁷ Harris
- ⁸⁸ Harris
- ⁸⁹ Beckman
- ⁹⁰ Gates (2)
- ⁹¹ Gates (1)
- ⁹² Fackler
- ⁹³ Department of Energy (2)
- ⁹⁴ Gates (2)
- ⁹⁵ SunEnergy
- ⁹⁶ Currie
- ⁹⁷ Twindell
- ⁹⁸ Currie
- ⁹⁹ Fackler
- ¹⁰⁰ Dixon
- ¹⁰¹ Cathcart
- ¹⁰² Sanyo
- ¹⁰³ SunEnergy
- ¹⁰⁴ Sanyo
- ¹⁰⁵ SunPower
- ¹⁰⁶ Fackler
- ¹⁰⁷ Renewable Energy
- ¹⁰⁸ Gates
- ¹⁰⁹ Renewable Energy
- ¹¹⁰ NPS

- ¹¹¹ Google Earth
- ¹¹² Gates
- ¹¹³ Hund, p. 1
- ¹¹⁴ Hund, p. 2
- ¹¹⁵ Hund, p. 3
- ¹¹⁶ Gates
- ¹¹⁷ Gates
- ¹¹⁸ National Fire Protection Association, p. 297-298.
- ¹¹⁹ National Fire Protection Association, p. 1024
- ¹²⁰ Wiles, p. 32-33
- ¹²¹ National Fire Protection Association, p. 1024
- ¹²² National Fire Protection Association, p. 1024
- ¹²³ National Fire Protection Association, p. 1029
- ¹²⁴ Wiles, p. 1-2
- ¹²⁵ Wiles, p. 1-2
- ¹²⁶ National Fire Protection Association, p. 297
- ¹²⁷ Wiles, p. 40
- ¹²⁸ Wiles, p. 42
- ¹²⁹ National Fire Protection Association, p. 1031
- ¹³⁰ National Fire Protection Association, p. 1021
- ¹³¹ Messenger, p. 91

REFERENCES

- Abundant Renewable Energy. "Specifications." ARE Wind Turbines. Accessed on September 6, 2007 from http://www.abundantre.com/ARE_Wind_Turbines.htm
- After Gutenberg. "Savonius Wind Turbine." Vertical Axis Wind Turbines. Accessed on February 3, 2008 from <http://jcwinnie.biz/wordpress/?p=1091>
- Alcatraz. Google Earth. Accessed on January 7, 2008 from <http://earth.google.com/>.
- Alcatraz Island. Wikipedia. Accessed on January 8, 2008 from <http://en.wikipedia.org/wiki/Alcatraz>
- American Wind Energy Association. "Basic Aerodynamic Operating Principles of Wind Energy." Resources. Accessed on February 3, 2008 from <http://www.awea.org/faq/basicop.html>
- Bergey Windpower Co. "Small Wind Turbines." Products and Prices. Accessed on September 6, 2007 from <http://www.bergey.com/>
- Brown, Chris. Sales Representative for the Alternative Energy Store. Email received from Chris Brown on October 19, 2007.
- Butterworth, Steve. Regional Energy Program Coordinator for National Park Service. "Alcatraz Log Book." Email received from Steve Butterworth on August 28, 2007.
- Castellini, Laura. Environmental and Safety Programs Officer for National Park Service. Personal Interview on July 20, 2007.
- Caterpillar. "Marine Auxiliary Engine 3306B." Marine Engine Specifications Sheet. 2001. Available at <http://www.cat.com/cda/files/99297/7/LEHM1559-00.pdf>.

Cathodic protection. Corrosion science and engineering information hub. 11
Apr. 2008 <<http://www.corrosion-doctors.org/CP/Introduction.htm>>

Clark, Cameron. Director of Environmental Affairs for Alcatraz Cruises.
Personal Interview on July 20, 2007

Clint, Michael. PacWind Inc. "Seahawk Turbine." Email received from Michael
Clint on December 6, 2007.

Currie, Glen. Business Development Manager at Sun Energy Limited. "Your
query on our website." Forwarded email received from Boyd Fackler on
November 27, 2007.

Department of Energy. "Estimating Appliance and Home Electronic Energy Use."
A Consumers Guide to Energy Efficiency and Renewable Energy.
September 12, 2005. Accessed on August 1, 2007 from
http://www.eere.energy.gov/consumer/your_home/appliances/index.cfm/mytopic=10040

Department of Energy. "When to Turn off Personal Computers." A Consumers
Guide to Energy Efficiency and Renewable Energy. September 12, 2005.
Accessed on February 3, 2008 from
http://www.eere.energy.gov/consumer/your_home/appliances/index.cfm/mytopic=10070

Department of Energy. "Solar Electric Power (PV)." Distributed Energy
Program. May 17, 2006. Accessed on February 12, 2008 from
http://www.eere.energy.gov/de/solar_electric.html

Dixon, Aaron. Unirac. Phone Interview on February 20, 2008

ECONOMIC STUDY: Si-COAT 579 versus Epoxy/Urethan 3-Coat System. by
CSL Silicones Inc. (2004)

Electric Power Transmission. Wikipedia. Accessed on March 17, 2007 from http://en.wikipedia.org/wiki/Electric_power_transmission

Energy Star. "LED Exit Signs." Products. Accessed on October 17, 2007 from http://www.energystar.gov/ia/products/prod_lists/exit_signs_prod_list.pdf

EPRI. "Methodology for Estimating Tidal Current Energy Resources and Power Production by Tidal In-Stream Energy Conversion Devices. EPRI Tidal In Stream Energy Conversion Project. September, 29 2006.

Fackler, Boyd. Ph.D. Candidate at University of Washington. "Wiring Diagram." Email received on December 3, 2007. "Wire Cost." Email received on February 21, 2008.

Gates, Scott. Idaho Power. Phone Interview on November 7, 2007.

Gates, Scott, Thomas Hund. "PV Hybrid System and Battery Test Results from Grasmere Idaho." IEEE Photovoltaic Specialists Conference. New Orleans, May 2002.

Google Earth. Accessed on March 5th 2008.

GCK Technologies. "Gorlov Helical Turbine." Accessed on July 30 from <http://www.gcktechnology.com/GCK/pg2.html>

Harris, Don. Harris Hydroelectric. Phone Interview on August 30, 2007.

Higher Heating Value. Wikipedia. Accessed on June 20, 2007 from http://en.wikipedia.org/wiki/Higher_heating_value

Johnson, Arthur. "Methods for producing hydro-electric power." U.S. http://en.wikipedia.org/wiki/Higher_heating_value

- Kaper, Kite Flying Around Wind Obstacles, "Boundary Layer."
http://www.kaper.us/basics/BASICS_040502_hunt_windflow.html
- Kiss and Cathcart, Architects. "Alcatraz Island National Historic District Building Integrated Photovoltaic System." Systematic Study: Preliminary and Final Report. March 1, 2002. Kiss and Cathcart Architects.
- Lawrence Berkeley National Laboratory. "National Park Service Alcatraz Island Energy-Efficiency Study Report." Energy Efficiency Study. November, 1996.
- Legends of America. "The History and Hauntings of Alcatraz." California Legends. Accessed on January 8, 2008 from
<<http://www.legendsofamerica.com/CA-Alcatraz.html>>
- Malte, Philip, Mary Hamann. "University-National Park Energy Partnership Program Status Report." Renewable Energy for Electricity Generation for Alcatraz Island. June, 2007.
- Malte, Philip, Mary Hamann. "University-National Park Energy Partnership Program Status Report." Renewable Energy for Electricity Generation for Alcatraz Island. September, 2007.
- Malte, Philip, Mary Hamann, Boyd Fackler "University-National Park Energy Partnership Program Status Report." Renewable Energy for Electricity Generation for Alcatraz Island. December, 2007.
- McAllister, Patrick. Alcatraz Island National Golden Gate Park Conservancy. Phone Interview. August 14, 2007.
- Megaman. "Megaman 11W GU10 Spotlight." eco-lighbulbs. Accessed on October 17, 2007 from http://eco-lighbulbs.com/index.php?main_page=product_info&cPath=42_48&products_id=152

Messenger, Roger, Jerry Ventre. Photovoltaic Systems Engineering. Boca Raton: CRC Press, 2000.

Microclimate. Wikipedia. Accessed on February 6, 2008 from <http://en.wikipedia.org/wiki/Microclimate>

National Fire Protection Association. The National Electrical Code Handbook. Boston: National Fire Protection Association, 2005.

National Oceanic and Atmospheric Association. "Current Station and Locations and Ranges." Tidal Current Predictions. December 14, 2007. Accessed on July 27, 2007. <http://tidesandcurrents.noaa.gov/currents08/tab2pc1.html#104>

National Park Service. "Emissions Calculations." Channel Islands National Park. December 27, 2000. Accessed on July 12, 2007 from <http://www.nps.gov/archive/chis/eemission.htm>

National Park Service. "The Industries." Alcatraz Island Circumnavigation Tour. Accessed on January 9, 2008 from <http://www.nps.gov/archive/alcatraz/tours/circ-nav/stop3.html>

National Solar Radiation Data Base. "Data Sets." Accessed on June 14, 2007 from http://rredc.nrel.gov/solar/old_data/nsrdb/

Pacific Gas & Electric. "Electric Rates." Rates and Regulations. Accessed on October 2, 2007 from <http://www.pge.com/notes/rates/tariffs/electric.shtml#COMMERCIAL>

PacWind, Inc. Products. Accessed on September 13, 2007 from <http://www.pacwind.net/>

Perez, Ricardo. National Park Service. Phone Interview. August 7, 2007.

Plant-Based Corrosion Inhibitors. DACCO SCI, INC. -- Corrosion Engineering, Materials Technology, Electrochemistry. 11 Apr. 2008 <http://www.daccosci.com/plant_extracts.htm>

Polagye, Brian. PhD Candidate at University of Washington. Personal Interview on July 27, 2007. "Wind Degradation." Email received on October 17, 2007. "Alcatraz Cable Spec." Email received on September 26, 2007.

Previsic, Mirko. Revision. "Fwd: Alcatraz Cable Spec." Forwarded email received from Brian Polagye on September 26, 2007.

Renewable Devices. "Specifications." The Swift Rooftop Energy System. Accessed on September 12, 2007 from <http://www.renewabledevices.com/swift/specification.htm>

Renewable Energy, ME 442. "Class Notes." University of Washington. Winter, 2007.

Renewable Resource Data Center. "TMY2 Data Files" Accessed on October 12, 2007 from http://rredc.nrel.gov/solar/old_data/nsrdb/tmy2/

Roy, D., G. P. Simon, M. Forsyth, and J. Mardel. "Towards a better understanding of the cathodic disbondment performance of polyethylene coatings on steel." Advances in Polymer Technology 21.1 (2002): 44-58.

San Francisco Bay. Google Maps. Accessed on January 7, 2008 from <http://maps.google.com/>.

Sanyo. "HIT Standard Solar Panels." Solar Products. Accessed on June 22, 2007 from <http://us.sanyo.com/solar/index.cfm?productID=1554>

Savonius Wind Turbine. Wikipedia. Accessed on February 3 from http://en.wikipedia.org/wiki/Savonius_wind_turbine

Si-COAT: Technology that Sticks.” By CSL Silicones Inc. (2000)

Si-COAT 579 versus Epoxy/Urethan 3-Coat System. by CSL Silicones Inc. (2004)

SunEnergy. “Technical Specifications – SunEnergy Three Phase Hybrid.” Products. Accessed on October 17, 2007 from <http://www.aesltd.com.au/solar-inverter-products.php>

SunPower. “SunPower 315 Data Sheet.” Solar Panels for Businesses. Accessed on June 22, 2007 from <http://www.SunPowercorp.com/Products-and-Services/Commercial-Solar-Panels.aspx>

Technical Information: Halar ECTFE 6914. by Solvay Solexis Inc.. 30 Jan. 2008.

Tide. Wikipedia. Accessed on January 15, 2008 from <http://en.wikipedia.org/wiki/Tide>

Twindell, John, Tony Weir. “Renewable Energy Resources.” Taylor and Francis Group, 1986.

USGS. “San Francisco Central Bay.” Near Real Time Current Velocity Maps. Accessed on September 6, 2007 from http://sfports.wr.usgs.gov/SFPORTS/vec_map/centbay.html

Verdant Power. “Free Flow Turbine Projects.” Accessed on July 30, 2007 from http://www.verdantpower.com/wp-content/themes/Verdant/downloads/VerdantPower_FFTEchProj.pdf

Walker, Andy. National Renewable Energy Laboratory. “Alcatraz Report.” Email from Andy received June 22, 2007.

Wilcox, Geoff. SunPower. Phone Interview on July 6, 2007.

Wiles, John. "Photovoltaic Power Systems and the 2005 National Electrical Codes Suggested Practices." Photovoltaic Systems Research and Development. February 2005. Sandia National Laboratories. Accessed on November 9, 2005 from <http://www.sandia.gov/pv/docs/John_Wiles_Code_Corner.htm>.

Windside Turbines. "Technical Data Page." Products. Accessed on September 12 from <http://www.windside.com/technical.html#WS-2B>

Appendix A: Energy Consumption Calculations

The average daily fuel consumption is 175 gallons per day and 7.3 gallons per hour. This corresponds to an average 50% load on the generator and thus an efficiency of 38.4%, however, the load varies between 75% of the rated capacity during the daytime and 25% during the nighttime. This was determined from the energy audit performed in Chapter 4. Also, there are additional power losses to heat caused by friction in the gear box and resistance in the transmission lines. Therefore, a conservative estimate of 34.5% is used for efficiency to convert the lower heating value of diesel into electric energy. The equation used to convert diesel consumption into electrical energy consumption per day is:

$$E_c = Fuel * 3.785 * \rho * LHV * \eta \quad \text{Equation: A1}$$

where,

- E_c is the electrical energy consumed each day at Alcatraz Island (kJ/day)
- $Fuel$ is the diesel consumption per day (gallons/day)
- 3.785 is the conversion from liters to gallons
- ρ is the density of diesel fuel (kg/liter)
- LHV is the lower heating value of diesel fuel (kJ/kg)
- η is the efficiency of the generator

Diesel fuel characteristics:

- Higher Heating Value (HHV): 45.9 MJ/kg
- Lower Heating Value (LHV): 43.0 MJ/kg
- Density (ρ): 850 g/L

The resulting value of Equation A1 is in kJ/day. In order to get average power, this value has to be divided by the number of seconds in the day. The result of Equation A2 is the average power in kW.

$$P = E_c / (3600 * 24)$$

Equation: A2

Appendix B: Summer Energy Demand

Building/Room	Lighting /Appliance	Quantity	Power (W)	Percent of time used	Daily Usage (hr)	Total Power (kW)	Energy kWh/day
Barracks - Dock Level							
Book Store	flood light	17	75	50%	12	1.275	15.3
	television	1	200	50%	12	0.2	2.4
	cash register	1	150	50%	12	0.15	1.8
	telephone	1	25	100%	24	0.025	0.6
	beverage cooler	1	250	100%	24	0.25	6
Visitor Center	incandescent bulb	6	60	50%	12	0.36	4.32
	visitor computer	2	150	50%	12	0.3	3.6
Electrical Room	F40T12 fixture	2	78	20%	4.8	0.156	0.7488
Storage	incandescent bulb	1	150	20%	4.8	0.15	0.72
First Aid	F40T12 fixture	5	78	50%	12	0.39	4.68
Canopy	incandescent bulb	1	300	50%	12	0.3	3.6
	CFL bulb	10	28	50%	12	0.28	3.36
Perimeter	HID	6	250	50%	12	1.5	18
	PA speaker	1	110	20%	4.8	0.11	0.528
Conservancy Admin Office	incandescent bulb	6	75	50%	12	0.45	5.4
	incandescent bulb	2	60	50%	12	0.12	1.44
	telephone	3	25	100%	24	0.075	1.8
	computer	2	120	100%	24	0.24	5.76
	monitor	2	150	50%	12	0.3	3.6
	printer	1	150	50%	12	0.15	1.8
Conservancy Retail Office	incandescent bulb	4	75	50%	12	0.3	3.6
	computer	2	120	100%	24	0.24	5.76
	monitor	2	150	50%	12	0.3	3.6
	printer	2	150	50%	12	0.3	3.6
	bill counter	1	60	25%	6	0.06	0.36
Conservancy Break Room	F40T12 fixture	5	78	50%	12	0.39	4.68
	refrigerator	1	775	100%	24	0.775	18.6
	microwave	1	1500	10%	2.4	1.5	3.6
	toaster oven	1	1225	10%	2.4	1.225	2.94
	coffee urn	3	500	50%	12	1.5	18

	television	1	175	10%	2.4	0.175	0.42
	water heater/cooler	1	500	50%	12	0.5	6

Restrooms - Dock Level							
Men's	toilet/urinal	6			0	0	0
	sink	2			0	0	0
	hand dryer	2	2000	25%	6	4	24
	F40T12 fixture	2	78	50%	12	0.156	1.872
	CFL bulb	1	28	50%	12	0.028	0.336
Women's	toilet	6			0	0	0
	sink	2			0	0	0
	hand dryer	2	2000	25%	6	4	24
	F40T12 fixture	1	78	50%	12	0.078	0.936
	CFL bulb	3	28	50%	12	0.084	1.008
	air curtain	1	600	100%	24	0.6	14.4
Staff	F40T12 fixture	1	78	20%	4.8	0.078	0.3744
Electrical Room	incandescent bulb	6	60	100%	24	0.36	8.64
	water pump	1	1000	40%	9.6	1	9.6
	sump pump	2	1000	40%	9.6	2	19.2
	compressor	2	2700	40%	9.6	5.4	51.84
	water heater	1	4500	40%	9.6	4.5	43.2
Restroom Perimeter	F40T12 fixture	2	78	100%	24	0.156	3.744
	CFL bulb	5	28	100%	24	0.14	3.36

Restroom - Cell House Level							
Men's	toilet/urinal	2			0	0	0
	sink	1			0	0	0
	hand dryer	1	2000	25%	6	2	12
	F40T12 fixture	1	78	50%	12	0.078	0.936
	CFL bulb	2	28	50%	12	0.056	0.672
Women's	toilet	2			0	0	0
	sink	1			0	0	0
	hand dryer	1	2000	25%	6	2	12
	F40T12 fixture	1	78	50%	12	0.078	0.936
	CFL bulb	2	28	50%	12	0.056	0.672
Staff	toilet	1			0	0	0
	sink	1			0	0	0
	F40T12 fixture	1	78	20%	4.8	0.078	0.3744

Electrical Room	incandescent bulb	4	60	100%	24	0.24	5.76
	water pump	1	1000	40%	9.6	1	9.6
	sump pump	2	1000	40%	9.6	2	19.2
	compressor	2	2700	40%	9.6	5.4	51.84
	water heater	1	4500	40%	9.6	4.5	43.2
Restroom Perimeter				100%	24	0	0

Barracks - Upper Level							
Entrance	flood light	8	75	100%	24	0.6	14.4
	F40T12 fixture	6	78	100%	24	0.468	11.232
Book Store	flood light	35	75	50%	12	2.625	31.5
	F40T12 fixture	2	78	50%	12	0.156	1.872
	cash register	1	150	50%	12	0.15	1.8
	television	1	250	50%	12	0.25	3
	telephone	1	25	100%	24	0.025	0.6
Theater	incandescent bulb	8	25	100%	24	0.2	4.8
	exit sign	5	52	100%	24	0.26	6.24
	projection system	4	2000	50%	12	8	96
	speaker	16	20	50%	12	0.32	3.84
Show Rooms	flood light	31	90	40%	9.6	2.79	26.784
	television	1	200	50%	12	0.2	2.4
Walk way	incandescent bulb	10	60	100%	24	0.6	14.4
	F40T12 fixture	1	78	100%	24	0.078	1.872
	exit sign	2	52	100%	24	0.104	2.496
Kitchen/Lunch Room	incandescent bulb	2	60	50%	12	0.12	1.44
	F40T12 fixture	4	78	50%	12	0.312	3.744
	refrigerator	1	725	100%	24	0.725	17.4
	freezer	1	600	100%	24	0.6	14.4
	coffee maker	1	1000	50%	12	1	12
	microwave	2	1500	10%	2.4	3	7.2
	toaster oven	1	1225	10%	2.4	1.225	2.94
	toaster	1	800	10%	2.4	0.8	1.92
water heater	1	2500	30%	7.2	2.5	18	
Interpretation Office							
Park Service Offices (3)	incandescent bulb	6	60	50%	12	0.36	4.32
	incandescent bulb	10	40	50%	12	0.4	4.8
	F40T12 fixture	8	78	50%	12	0.624	7.488
	CFL bulb	1	28	50%	12	0.028	0.336
	computer	9	120	50%	12	1.08	12.96

	monitor	9	150	50%	12	1.35	16.2
	television	1	175	10%	2.4	0.175	0.42
	vcr	1	120	10%	2.4	0.12	0.288
	telephone	7	25	100%	24	0.175	4.2
	fax machine	1	120	100%	24	0.12	2.88
	printer	5	150	50%	12	0.75	9
	copier	1	250	50%	12	0.25	3
	electric heater	2	1500	0%	0	3	0
	electric heater	1	500	0%	0	0.5	0
	elevator	1	15,000	5%	~20 times/day	15	18
Storage Room	incandescent bulb	6	60	100%	24	0.36	8.64
	CFL bulb	3	28	100%	24	0.084	2.016
Conservancy Office	incandescent bulb	1	60	50%	12	0.06	0.72
	F40T12 fixture	4	78	50%	12	0.312	3.744
	flood light	6	90	50%	12	0.54	6.48
	computer	3	120	100%	24	0.36	8.64
	monitor	3	150	50%	12	0.45	5.4
	printer	2	150	50%	12	0.3	3.6
	electric heater	2	1,000	0%	0	2	0
Change Counting Room	F40T12 fixture	1	78	50%	12	0.078	0.936
	change counter	2	50	25%	6	0.1	0.6

Sally Port							
Electric Shop	F40T12 fixture	6	78	40%	9.6	0.468	4.4928
	welder	1	5000	0%	0	5	0
	electric saw	1	400	0%	0	0.4	0
Kitchen/Lunch Room	microwave	1	1200	0%	0	1.2	0
	refrigerator	1	600	0%	0	0.6	0
Perimeter	incandescent bulb	3	200	50%	12	0.6	7.2
	HID	7	450	50%	12	3.15	37.8
	CFL bulb	4	28	100%	24	0.112	2.688

Cell House							
MP3 Rental	Incandescent bulb	2	60	50%	12	0.12	1.44
	4F40T12 fixture	6	159	50%	12	0.954	11.448
	CFL bulb	2	28	50%	12	0.056	0.672
	exit sign	1	52	100%	24	0.052	1.248
	MP3 charger	1	2000	100%	24	2	48
	electric wall heater	2	2000	0%	0	4	0
Dining Hall	Incandescent bulb	13	52	50%	12	0.676	8.112

Kitchen	Incandescent bulb	4	52	50%	12	0.208	2.496
Hospital ER	Incandescent bulb	1	300	10%	2.4	0.3	0.72
Hospital Upstairs	Incandescent bulb	19	52	10%	2.4	0.988	2.3712
Cell Block A West	Incandescent bulb	56	52	100%	24	2.912	69.888
Cell Block A East	Incandescent bulb	36	52	0%	0	1.872	0
	CFL bulb	6	13	0%	0	0.078	0
Cell Block A East Wall	Incandescent bulb	2	52	100%	24	0.104	2.496
	CFL bulb	3	13	100%	24	0.039	0.936
Cell Block B	Incandescent bulb	94	52	100%	24	4.888	117.312
	CFL bulb	18	13	100%	24	0.234	5.616
Cell Block C	Incandescent bulb	80	52	100%	24	4.16	99.84
	CFL bulb	32	13	100%	24	0.416	9.984
Cell Block D	Incandescent bulb	21	52	100%	24	1.092	26.208
Cell Block D West Wall	Incandescent bulb	27	52	100%	24	1.404	33.696
Cell Block Ceiling	Incandescent bulb	15	300	100%	24	4.5	108
Library Ceiling	Incandescent bulb	2	200	100%	24	0.4	9.6
Control Room	Incandescent bulb	5	52	100%	24	0.26	6.24
	F40T12 fixture	18	78	100%	24	1.404	33.696
Visitation	Incandescent bulb	4	100	100%	24	0.4	9.6
Warden Office	Incandescent bulb	4	52	100%	24	0.208	4.992
Barber Shop	CFL bulb	2	13	100%	24	0.026	0.624
Shower Room	Incandescent bulb	8	100	100%	24	0.8	19.2
Chapel	Incandescent bulb	7	52	10%	2.4	0.364	0.8736
Citadel	Incandescent bulb	29	60	5%	1.2	1.74	2.088
Hallway	Incandescent bulb	3	150	100%	24	0.45	10.8
	CFL bulb	3	28	100%	24	0.084	2.016
	exit sign	2	52	100%	24	0.104	2.496
Book Store	F40T12 fixture	5	78	50%	12	0.39	4.68
	flood light	550	50	50%	12	27.5	330
	cash register	4	150	50%	12	0.6	7.2
	television	4	225	50%	12	0.9	10.8
	electric wall heater	2	2000	0%	0	4	0

Park Service Offices (2)	Incandescent bulb	3	52	50%	12	0.156	1.872
	Incandescent bulb	4	60	50%	12	0.24	2.88
	F40T12 fixture	4	78	50%	12	0.312	3.744
	computer	3	120	50%	12	0.36	4.32
	monitor	3	150	50%	12	0.45	5.4
	electric wall heater	2	2000	0%	0	4	0
	elevator	1	15000	5%	1.2	15	18
Conservancy Offices (3)	F40T12 fixture	22	78	50%	12	1.716	20.592
	computer	2	120	100%	24	0.24	5.76
	monitor	2	150	50%	12	0.3	3.6
	printer	5	150	50%	12	0.75	9
	electric wall heater	3	2000	0%	0	6	0
Conservancy Conference Room	fluorescent lighting				0	0	0
	electric wall heater	1	2000	0%	0	2	0
Kitchen/Lunch Room	F40T12 fixture	17	78	50%	12	1.326	15.912
	refrigerator	2	725	100%	24	1.45	34.8
	freezer	1	600	100%	24	0.6	14.4
	toaster oven	2	1225	10%	2.4	2.45	5.88
	toaster	1	800	10%	2.4	0.8	1.92
	coffee maker	1	1000	50%	12	1	12
	microwave	2	1500	10%	2.4	3	7.2
	water heater	1	2500	30%	7.2	2.5	18
	television	1	175	10%	2.4	0.175	0.42
	vcr	1	110	10%	2.4	0.11	0.264
	electric wall heater	1	2000	0%	0	2	0
Roof	Incandescent bulb	12	300	50%	12	3.6	43.2
Perimeter	Incandescent bulb	7	150	50%	12	1.05	12.6
	Incandescent bulb	4	75	50%	12	0.3	3.6

Removed	Incandescent bulb	-20	52	100%	24	-1.04	-24.96
Installed	CFL bulb	20	13	100%	24	0.26	6.24
						0	0
Removed	F40T12 fixture	0	78	20%	4.8	0	0
Removed	F40T12 fixture	0	78	40%	9.6	0	0
Removed	F40T12 fixture	-53	78	50%	12	-4.134	-49.608
Removed	F40T12 fixture	-27	78	100%	24	-2.106	-50.544
Installed	F32T8EB fixture	0	58	20%	4.8	0	0

Installed	F32T8EB fixture	0	58	40%	9.6	0	0
Installed	F32T8EB fixture	27	58	100%	24	1.566	37.584
Installed	F32T8EB fixture	53	58	50%	12	3.074	36.888

Light House							
light house	light	1	1500	100%	24	1.5	36
	motor	1	2500	100%	24	2.5	60

Miscellaneous							
	Electric Cars	3	1000	50%	12	3	36
	electric tram	2	1000	50%	12	2	24

total						250.51	2361.8
-------	--	--	--	--	--	--------	--------

Appendix C: Solar Energy Availability Analysis

Solar Angles

- θ = solar incidence angle
The angle between a vector normal to the surface of a solar collector and the direct beam radiation vector.
- Φ = latitude angle
The angle between the equator and the location north or south of a solar collector.
- δ = solar declination angle
Tilt of the earth's axis of rotation with respect to the sun (varies between 23.5°N during the summer solstice and -23.5°S at the winter solstice), which is represented by Equation C1.

$$\delta = 23.5 * \sin\left(\frac{360 * (285 + n)}{365}\right) \quad \text{Equation: C1}^1$$

Where n represents the day of the year, starting with January 1 and ending on December 31.

- ω = hour angle
The angle between the longitudinal position of a solar collector and the longitude where solar noon is occurring on the earth. Solar noon is defined as the time when the sun reaches the highest point in the sky relative to a location. The sun rotates 15° per hour, with solar noon defined as the zero hour angle, decreasing to the east and increasing to

¹ Renewable Energy

the west. Standard time must be converted to a 24 hour scale, then solar noon can be calculated to convert standard time into solar time. The hour angle can be found using the following equations.

$$SolarNoon = \frac{(Sunrise + Sunset)}{2} \quad \text{Equation: C2}$$

$$SolarTime = StandardTime - SolarNoon \quad \text{Equation: C3}$$

$$\omega = SolarTime * 15^\circ \quad \text{Equation: C4}$$

The remaining solar angles are depicted in the following figure and defined below.

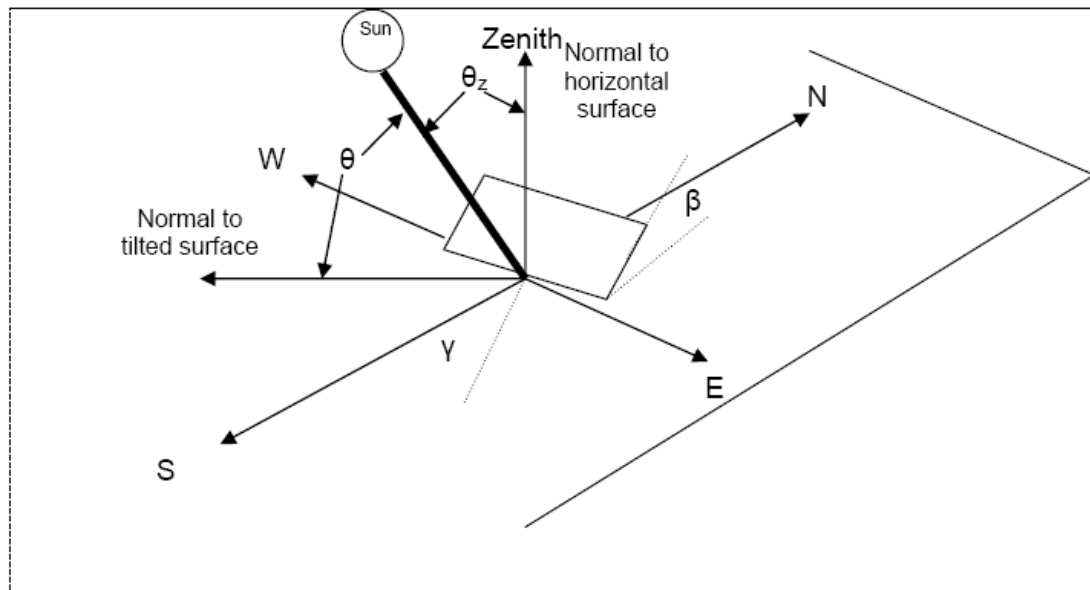

Diagram of the Solar Angles: θ_z , θ , β and γ .²

² Renewable Energy

- β = panel tilt angle
Angle between a solar collector and the horizontal surface of the earth
- γ = solar azimuth angle
The angle between a vectors from a collector to the sun projected on the ground and a vector facing due south
- θ_z = solar zenith angle
Angle between a vector normal to the horizontal surface of the earth and the direct beam radiation vector

For a solar collector placed on a horizontal surface, the amount of solar radiation that the collector receives is defined by the solar zenith angle, given by the following equation.

$$\cos(\theta_z) = \sin(\phi) \sin(\delta) + \cos(\phi) \cos(\delta) \cos(\omega) \quad \text{Equation: C2}^3$$

If a solar module is tilted off of the horizontal surface, the panel tilt angle and solar azimuth angle have to be incorporated into the analysis. The new equation for the angle between a vector normal to a panel and the direct solar radiation is defined in Equation C3.

$$\begin{aligned} \cos(\theta) = & \sin(\phi) * \cos(\beta) * \sin(\delta) \\ & - \cos(\phi) * \sin(\beta) * \cos(\gamma) * \sin(\delta) \\ & + \sin(\beta) * \sin(\gamma) * \sin(\omega) * \cos(\delta) \\ & + \cos(\phi) * \cos(\beta) * \cos(\omega) * \cos(\delta) \\ & + \sin(\phi) * \sin(\beta) * \cos(\gamma) * \cos(\omega) * \cos(\delta) \end{aligned} \quad \text{Equation: C3}^4$$

³ Renewable Energy

⁴ Renewable Energy

Once the solar incidence angle has been determined, it is possible to calculate how much beam and diffuse solar radiation is received by the module. For a horizontal module the equation is simply the total global solar energy flux striking a horizontal surface.

$$G_t = G_b * \cos(\theta) + G_d \quad \text{Equation: C4}^5$$

Where,

- G_t is the total solar energy flux striking a horizontal surface (W/m²)
- G_b is the direct beam solar energy flux (W/m²)
- G_d is the diffuse solar energy flux on a horizontal surface (W/m²)

Solar radiation is almost always measured in terms of its direct and diffuse components. If a module is tilted off of the horizontal, though, a reflected radiation term has to be included in the analysis. This is portion of the total radiation that is reflected off of a horizontal surface and onto a tilted collector. The total solar flux received by a collector is determined with Equation C5.

$$G_C = G_b * \cos(\theta) + G_d * \cos^2\left(\frac{\beta}{2}\right) + \rho * G_t * \sin^2\left(\frac{\beta}{2}\right) \quad \text{Equation: C5}^6$$

where,

- G_C is the total solar energy flux striking a collector (W/m²)
- ρ is the reflectivity of the ground, ranging between 0.2 for regular ground and 0.8 for snow.

The power produced by a solar panel installation is a function of the total solar flux striking the panels, the area of the panels and their efficiency.

⁵ Renewable Energy

⁶ Renewable Energy

$$P = G_c * A * \eta$$

Equation: C6⁷

- P is the power available from the solar modules (W)
- A is the total surface area of the solar modules (m²)
- η is the efficiency of the solar modules

Solar modules are temperature dependent and all modules have a rated temperature associated with their rated efficiency. For every degree above the rated temperature the module efficiency decreases by a given percentage, and for every degree below the rated temperature the efficiency increases by the same percentage. The efficiency of solar modules is commonly rated for a collector temperature of 25°C. The temperature of a solar collector is not simply the temperature of the ambient air, but is a function of the solar flux striking the panel and the wind speed that provides convective cooling of the module. The collector temperature is defined in the following relationship.

$$G_c * A = \varepsilon * \sigma * A * (T_c^4 - T_{sky}^4) + (a + b * U) * A * (T_c - T_{amb}) \quad \text{Equation: C7}^8$$

where,

- ε is the emissivity of thermal radiation to the environment
- σ is the Stefan-Boltzman constant (5.67e-8 W/m²-K⁴)
- T_c is the temperature of the collector (K)
- T_{amb} is the ambient air temperature (K)
- T_{sky} is the sky temperature ($T_{amb} - 6K$)
- a is a constant (5.7W/m²-K)
- b is a constant (3.8 W/m²-K-m/s)

⁷ Renewable Energy

⁸ Renewable Energy

- U is the wind speed (m/s)

Equation C7 is a quadratic equation that has to be solved for the collector temperature. Once that is known, the temperature corrected power output of the solar modules can be calculated.

$$P_{tc} = P * (1 - T_{coef} * (T_C - 25)) \quad \text{Equation: C8}^9$$

- P_{tc} is the temperature corrected power output of the solar modules (W)
- T_{coef} is the temperature coefficient, or the percentage of the power change per degree (.29%/°C for the Sanyo 200 W)

Once the power output of a solar system is known it is possible to calculate the total energy produced. Energy is defined as power multiplied by time, for example W*hr. All of the solar irradiation, wind and temperature data is given on an hourly basis, so the total energy produced each hour is the power multiplied by one hour. The energy production each month is the sum of the energy produced each hour over the month. Likewise, the yearly energy production is the sum of the energy produced each hour for the entire year.

⁹ Renewable Energy

Appendix D: Wind Energy Availability Analysis

Wind power is founded on the idea that energy is available from a pressure difference created across an area or boundary. A pressure drop across a boundary results in a loss in kinetic energy across the same boundary, with little change in potential energy. The kinetic energy that is lost is then converted into another kind of energy, which can be used to move a turbine. When that pressure change, and thus energy change, is determined on a per time basis, it becomes power. The amount of power available from the wind is represented by the following equation.

$$P_w = \frac{1}{2} * \rho * A * U^3$$

Equation: D1¹⁰

where,

- P_w is the power available from the wind (J/s or W)
- ρ is the density of air (kg/m³)
- A is the cross sectional area perpendicular to the direction of the wind (m²)
- U is the speed of the wind (m/s)

It is impossible for all of the power of the wind to be imparted to a wind turbine. The portion of power transferred, or efficiency, is completely dependent upon the change in the speed of the wind as it passes through the blades of the turbine. The best possible condition occurs when the speed of the wind through the turbine is 2/3 of the wind speed upstream from the turbine and the speed of the wind downstream of the turbine is 1/3 of the upstream wind speed. This situation corresponds to a 59% transfer of the wind power into the power output of a turbine, and is known as the Betz Criterion. The relationship between upstream, through, and downstream wind speed is dictated by the size of a turbine, the

¹⁰ Renewable Energy

number, the axis of rotation, the ability to adjust the pitch of the blades and the tip speed ratio of the blades. The Betz limit is an extremely ideal case and is not achievable with current turbine technology. The efficiency of wind turbine ranges between 15% and 48%. The power output of a wind turbine is given in Equation D2.

$$P_w = \frac{1}{2} * \rho * A * U^3 * \eta$$

Equation: D2

- P is the power output of a wind turbine (W)
- A is the swept area of the blades of a wind turbine (m²)
- η is the efficiency of a wind turbine

Similar to the solar energy analysis, wind speed data is available every hour so the power production each hour is calculated, multiplied by one hour, and added together to obtain monthly and yearly energy production values. A turbine cannot produce power at any wind speed because a minimum speed is required just to turn the blades. This is called the cut in wind speed, and is usually around 1-5 m/s. Therefore, any wind that is below the cut in wind speed of a turbine has to be excluded from the analysis. Likewise, wind turbines have a cut out speed at which they cease to produce power and shut down, this prevents them from becoming damaged in very high winds. Any wind that is greater than the cut out speed of the turbine must also be excluded from the power output calculation. The final consideration is the behavior of the wind as it travels past a turbine. After the wind passes the first row of wind turbines its speed is reduced to 60-70% of its original speed, then there is only a slight decline after each subsequent row. All of these considerations were included in the calculation of wind energy output.

Appendix E: Tidal Energy Availability Analysis

The equation for the power available from tidal currents is almost identical to the equation for wind power availability. Both are proportional to the density of the fluid that is moving and the cube of the speed of the fluid. In this case tidal power, it is common to characterize a site by the tidal power density, rather than calculate the specific power output of a turbine. This simplifies the calculation to the following equation.

$$P_T = \frac{1}{2} * \rho * U^3$$

Equation: E1¹¹

Where

- P_T is the power density of the tidal current (W/m²)
- ρ is the density of water (kg/m³)
- U is the speed of the water (m/s)

Tidal current speed data is not available on an hourly basis, as it was for the wind and solar data, but only the two maximum flood and ebb current velocities are given for each day. Brian Polagye has created a code, based on the EPRI tidal current estimation methodology report, which can predict the hourly current velocity based upon the four daily maximum current velocities. Once the hourly current velocity is known, the hourly power density can be calculated. The average power density for the year is used to characterize the site.

¹¹ Polagye

Appendix F: Pumped Storage Capacity Analysis

A pumped storage energy systems works by harnessing excess energy produced during the day from a renewable energy system or generator to pump water up to the height of the water tower where it then has potential energy. The water is stored at this elevation until a time when energy can no longer be produced by the renewable resource, and then it is discharged back down to sea level and run through a hydroelectric turbine where its potential energy is converted into kinetic energy. The total amount of energy that can be produced by this method is dependent upon the height of the storage reservoir, the amount of water, and the efficiency of each component. The number of hours a system can be run or the power rating can be modified by changing the size of the discharge pipe. The first parameter calculated is the velocity of the jet stream at the location of the turbine, seen in Equation F1.

$$V_J = \sqrt{.5 * H * g} \quad \text{Equation: F1}^{12}$$

Where,

- V_J is the velocity of the jet stream (m/s)
- H is the height of the tower (m)
- g is gravity (9.8 m/s²)

The next relationship is used to calculate the power available from the jet stream.

$$P_J = \rho * g * Q * H \quad \text{Equation: F2}^{13}$$

- P_J is the power of the jet stream of water (W)

¹² Renewable Energy

¹³ Renewable Energy

- ρ is the density of water (kg/m^3)
- Q is the flow rate of the water (m^3/s)

The water flow rate is completely dependent upon the dimensions of the pipe that the water travels through and the velocity of the jet stream, which is dependent upon the height of the reservoir. The height of a reservoir cannot usually be modified, but the diameter of the penstock can be changed in order to change the power available from the jet stream. This will also have an effect on how long the system can produce power, which is a function of the volume of water in the reservoir and the flow rate of the water. The electrical power put out by the turbine is a portion of the total power available from the jet stream.

$$P_E = P_J * \eta_P * \eta_T * \eta_G$$

Equation: F3¹⁴

Where

- P_E is the electrical output of the turbine (W)
- η_P is the efficiency of the penstock (~90%)
- η_T is the efficiency of the turbine (~85%)
- η_G is the efficiency of the generator (~98%)

Pump storage is not efficient on as small scale, but it work well for a utility scale System. This is because of the initial power losses in the pump, around 80%, and the low efficiency of a small, Pelton Wheel turbine around 80-85%.¹⁵

¹⁴ Renewable Energy

¹⁵ Harris

Appendix G: Economic Analysis – Annuity Method

Energy that is purchased from the power grid has an energy cost assigned to it that dictates the resulting monthly bill based on the amount consumed. For non grid energy, such as a renewable energy system or diesel generator, the cost of energy has to be calculated based on the energy production and the total cost. This value is generally calculated on a per year basis and the energy cost is defined by the following equation.

$$COE = \frac{C_p}{E_p} \quad \text{Equation: F1}^{16}$$

Where,

- COE is the cost of energy (\$/kWh)
- C_p is the production cost (\$)
- E_p is the amount of energy produced (kWh)

Although it is relatively easy to determine the yearly energy production of an energy system, it is not as simple to determine the total yearly cost to produce the energy. The production costs include the capital expense of the equipment and the operational cost to run and maintain the system. For a diesel generator, the operational costs also include the cost of fuel for the year and the equivalent cost of its pollutants on the environment. Operational costs are defined on a per year basis, but the capital expense is a lump sum used to purchase and install all of the necessary equipment. If the entire capital was paid in the first year of operation, the production cost would be extremely high and thus the cost of energy, making the project unfeasible. It is common to obtain a loan to cover the capital expenses up front and then pay a portion of the loan back every year over

¹⁶ Renewable Energy

the life of the equipment. This method converts the capital expense into a reasonable yearly cost and is referred to as the annualized method.

As mentioned, the capital expense is not only the cost of the equipment, but the cost to get then system running, including permits and installation. Installation is sometimes estimated as a percentage of the capital cost, in this case a value of 10% is used. After the total capital expense is known, it can be converted into a yearly cost using the capital recovery factor given and defined below.

$$CRF = \frac{i}{1 - (1 + i)^{-n}}$$

Equation: F2¹⁷

- CRF is the capital recovery factor, or the percentage of the capital that has to be paid each year for the duration of the project
- i is the annual interest rate of the loan
- n is the duration of the project in years

The yearly capital cost is then obtained by multiplying the total capital cost by the CRF. For this project an interest of 8% is incorporated, and the project is defined for 20 years because that is the lifetime of the solar panels. The annual production cost is now defined by this equation.

$$C_{pannual} = CapEx + OpEx - AnnualSalvage$$

Equation: F3¹⁸

- $C_{pannual}$ is the annual cost of energy production
- CapEx is the total capital expense
- OpEx is the operating expense

¹⁷ Renewable Energy

¹⁸ Renewable Energy

- Annual Salvage is the salvage value of the equipment at the end of the project converted to an annual gain

The equipment is assumed to have no salvage value at the end of the project, so there is no recovery cost included in the analysis.

Appendix H: Wiring Diagrams for the 346 kW Solar Array

Although the 346 kW system is very similar to the 115 kW system as far as components, there are a couple of main differences. First of all, the SunEnergy Solar Regulator (charge controller) can accept a maximum of 6 inputs. In order to minimize the amount of regulators required, the optimal sub-array for this system is composed of nine strings instead of six as shown in Figure 52.

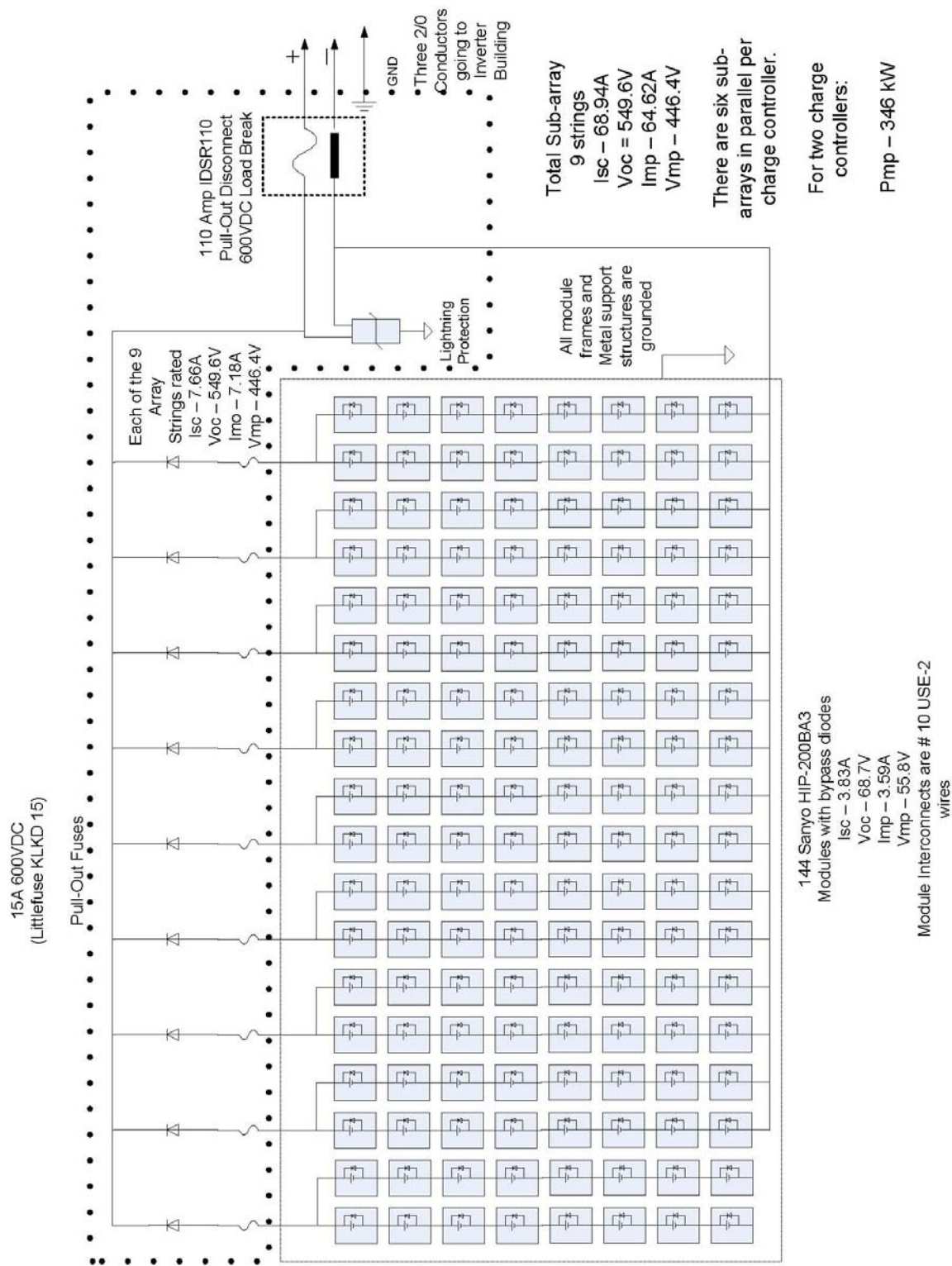

Figure 52: Sub-array for the 346 kW system.

Thus, the source circuit conductors and over-current protection devices have been sized to accommodate the larger current. There is also one extra input to the battery bank as shown in Figure 53. Where the 115 kW array has a positive input corresponding to the generator and one solar regulator, the 346 kW array has two inputs for each solar regulator. If an additional power generator such as wind should be incorporated into this system, there would be additional inputs to the positive bus shown in Figure 55. Take note that the maximum charging current should still be limited to 800 amps for any additional power generator added to the system.

The other main difference is the larger inverter required for the 346 kW array. A SunEnergy 400kVA inverter has been selected for this system. The batteries can now be charged at the full charging rate of C/10, 800 amps. Thus, the conductors and over-current devices on the AC side of the system have been augmented to 800 kcmil and 1000A fuses to allow for this increased current.

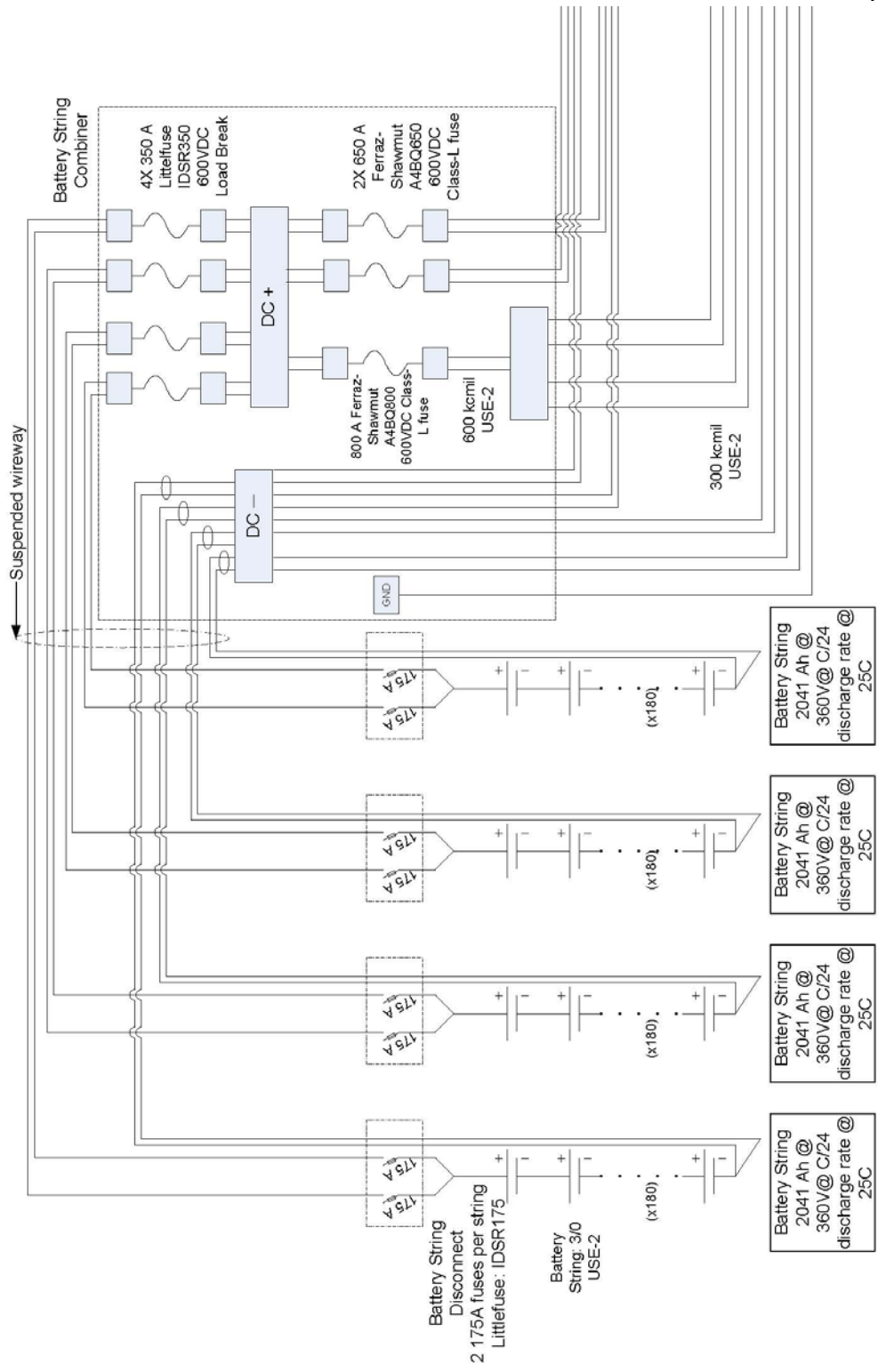

Figure 53: Battery bank wiring for the 346 kW array.

1. Each sub-array is fed through two 3 pole fusible disconnects and eventually ganged after all the relays at the terminal block prior to the 650A fuse. Actual wiring is not shown for simplicity.

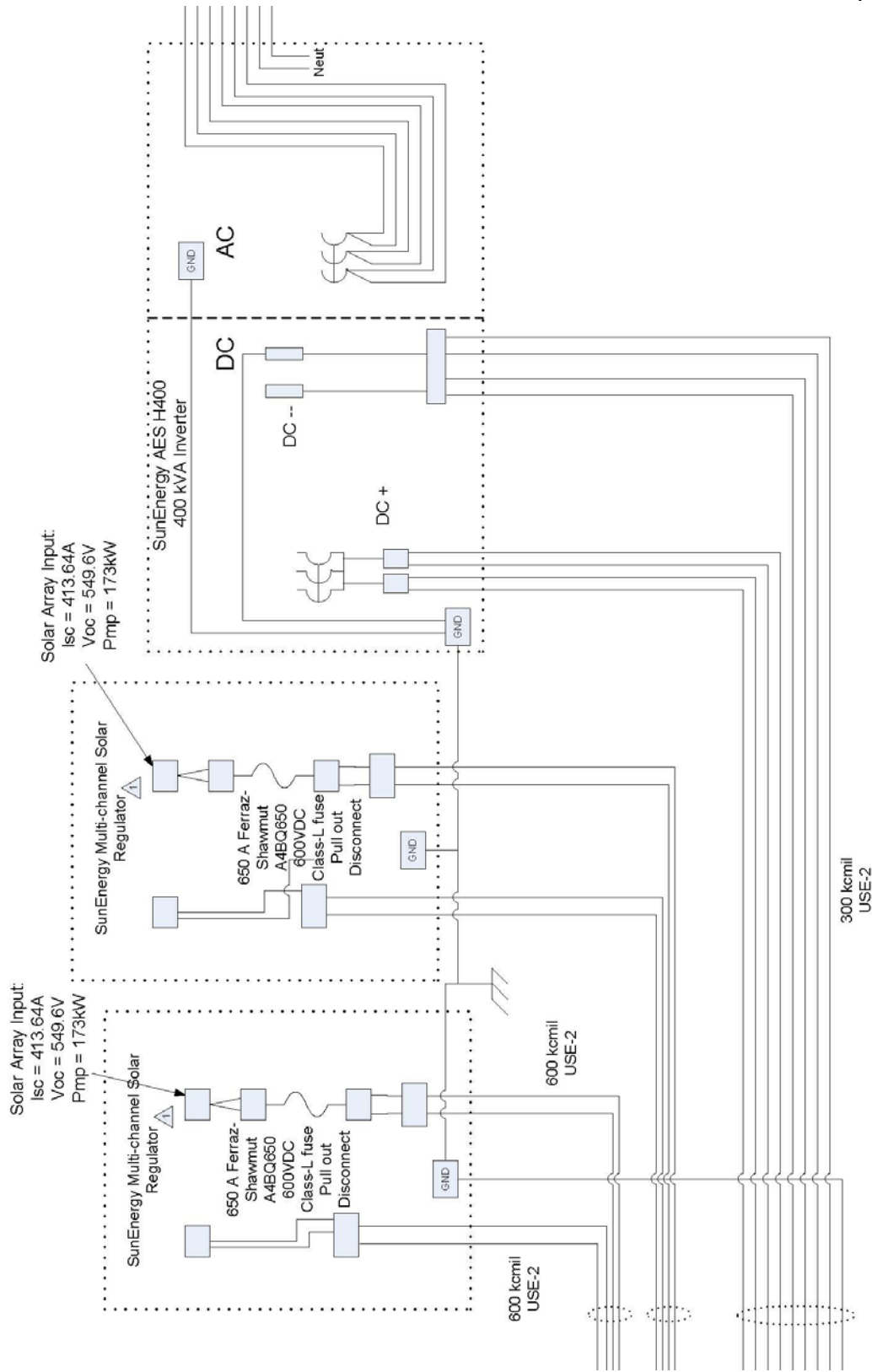

Figure 54: DC to AC wiring diagram for the 346 kW system.

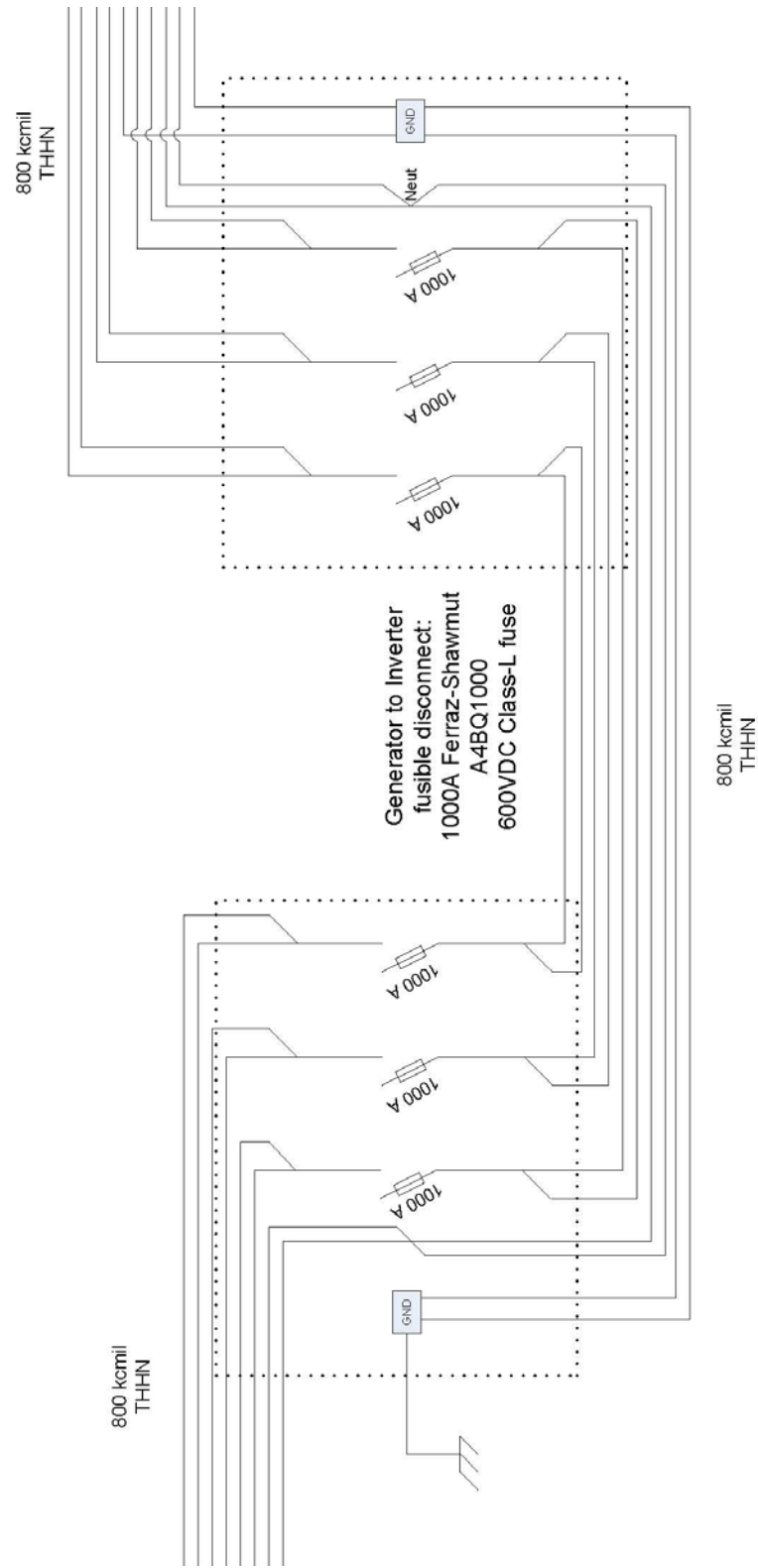

Figure 55: Inverter to Generator Wiring Diagram for the 346 kW system.

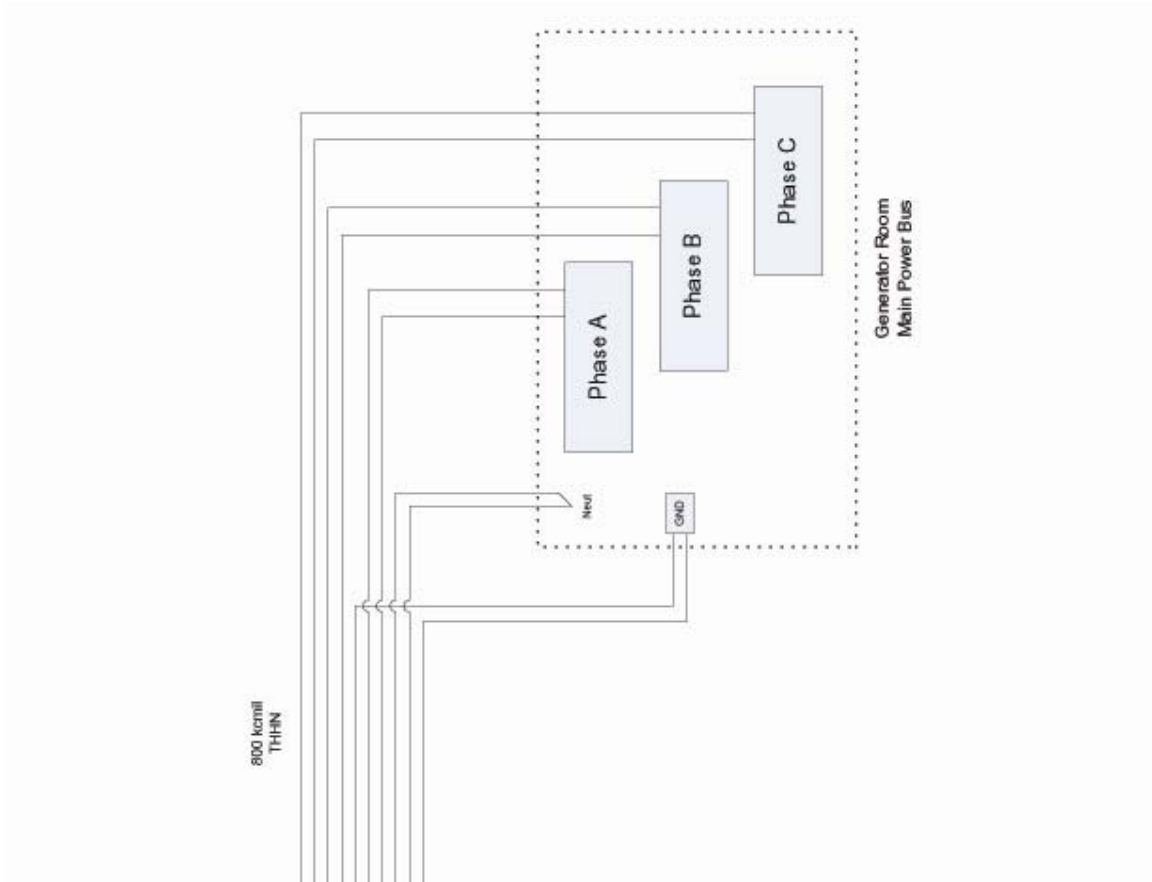

Figure 56: Main Generator Bus Diagram for the 346 kW system.