



# MIT Media Lab's Concept Car: with GM and Frank O. Gehry

General Motors, by developing and critically designs for a concept car. The eventual out further development and documentation of will be construction of a full-scale, running p car will be hybrid powered, and drive-by-wire sufficient intelligence to know the city that it provide not just transportation, but an efficie interface to the resources that the city offers particularly concerned with innovative electr wares, new materials and processes, and th for interior space, exterior form, and the exp driving. We will work from the beginning in a 3D geometric modeling environment (Catia make extensive use of rapid prototyping an for producing physical scale models.

## Smart Cities Group

**Professor William J. Mitchell**

Head, Media Arts and Sciences Program

**Graduate Students:**

Ryan Chin, PhD Candidate

Will Lark, MS Candidate

Phil Liang, MS Candidate

Patrik Künzler, Safdie Fellow

Raul David "Retro" Poblano, UROP

Peter Schmitt, Visiting Researcher

Susanne Seitinger, MS Candidate

**MIT Media Lab**

**Oct 22, 2004**

**Collaborators:**

Federico Casalegno, Visiting Scientist

David Gerber, Safdie Fellow

Mitchell Joachim, PhD Candidate

Axel Kilian, PhD Candidate

Franco Vairani, Research Scientist

# Concept Car with GM and Frank O. Gehry

General Motors, by developing and critically designs for a concept car. The eventual out further development and documentation of will be construction of a full-scale, running car will be hybrid powered, and drive-by-wire sufficient intelligence to know the city that it provide not just transportation, but an efficient interface to the resources that the city offers particularly concerned with innovative electronics, new materials and processes, and the for interior space, exterior form, and the experience of driving. We will work from the beginning in a 3D geometric modeling environment (Catia) make extensive use of rapid prototyping and for producing physical scale models.

## 1. Motor-Wheel

Electrically powered, independently controllable **wheels** with motor, suspension, brakes, and steering contained within each wheel assembly. Placing the suspension within the wheel itself is a significant innovation, and promises some important advantages. Each wheel has only two inputs: electrical power and digital data.



*Goal: Create self-contained mobile units*

# Concept Car with GM and Frank O. Gehry

General Motors, by developing and critically designs for a concept car. The eventual out will be construction of a full-scale, running car will be hybrid powered, and drive-by-wire sufficient intelligence to know the city that it provide not just transportation, but an efficient interface to the resources that the city offers particularly concerned with innovative electronics, new materials and processes, and the for interior space, exterior form, and the experience of driving. We will work from the beginning in a 3D geometric modeling environment (Catia) make extensive use of rapid prototyping and

## 2. Exoskeleton

An **exoskeleton** that connects the wheels and supports the passenger cabin, storage units, and power source. This element can be optimized for structural efficiency, and (like the frame of a sophisticated bicycle) can become a major design feature.

*Goal: High level of customization*



# Concept Car with GM and Frank O. Gehry

General Motors, by developing and critically designs for a concept car. The eventual out further development and documentation of will be construction of a full-scale, running car will be hybrid powered, and drive-by-wire sufficient intelligence to know the city that it provide not just transportation, but an efficient interface to the resources that the city offers particularly concerned with innovative electronics, new materials and processes, and the for interior space, exterior form, and the experience of driving. We will work from the beginning in a



### 3. Drive-by-Wire

In place of traditional steering column and dashboard arrangements. This allows radical reconfiguration of the cockpit, treatment of the passenger compartment as a module that can readily be separated from the rest of the car, and creation of a multimedia driving experience that intelligently integrates data streams from a wide variety of sources and presents them to the driver and passengers in a customized, context-sensitive way.

*Goal: Interior Design Freedom*

# Concept Car with GM and Frank O. Gehry

General Motors, by developing and critically designs for a concept car. The eventual out will be construction of a full-scale, running car will be hybrid powered, and drive-by-wire sufficient intelligence to know the city that it provide not just transportation, but an efficient interface to the resources that the city offers particularly concerned with innovative electronics, new materials and processes, and the for interior space, exterior form, and the experience of driving. We will work from the beginning in a 3D geometric modeling environment (Catia) make extensive use of rapid prototyping and for producing physical scale models.

## 4. No Crumple

A lightweight, technologically advanced **passenger compartment** suspended safely within the exoskeleton, like an egg protected within an egg carton. This compartment need not be fabricated from sheetmetal and glass. It can exploit the possibilities of advanced materials and embedded electronics to provide high levels of visibility, safety, climate control, lighting, sensing capability, and interior displays. And it provides an opportunity to break away from the familiar automobile aesthetic of painted sheetmetal

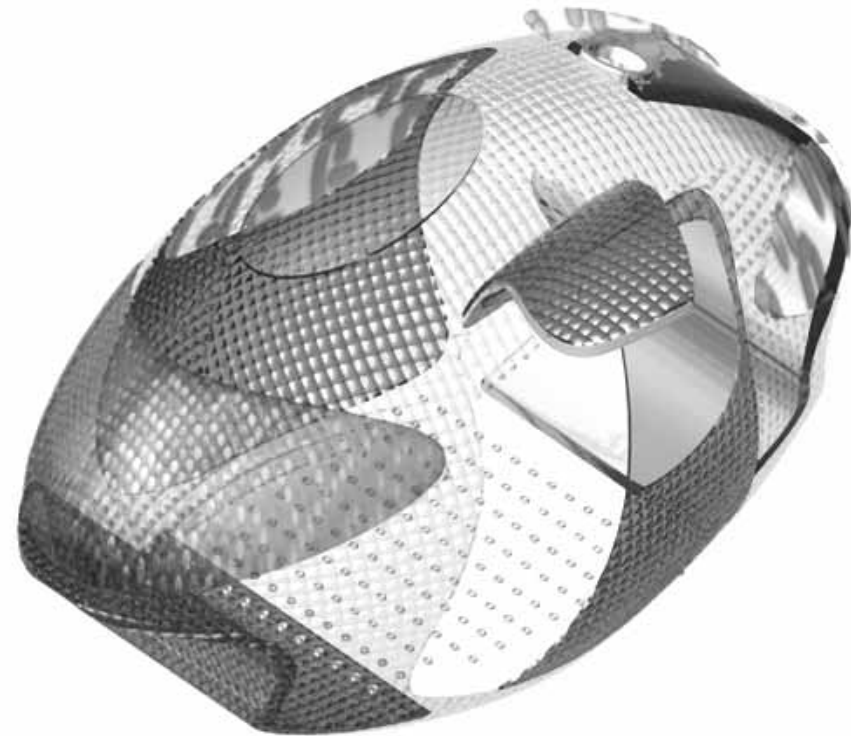

# Concept Car with GM and Frank O. Gehry

General Motors, by developing and critically designs for a concept car. The eventual out further development and documentation of will be construction of a full-scale, running car will be hybrid powered, and drive-by-wire sufficient intelligence to know the city that it provide not just transportation, but an efficient interface to the resources that the city offers particularly concerned with innovative electronics, new materials and processes, and the for interior space, exterior form, and the experience of driving. We will work from the beginning in a 3D geometric modeling environment (Catia) make extensive use of rapid prototyping and for producing physical scale models.

## 5. Hold Safely

Go beyond seatbelts and airbags. Think of the passenger seat, from the beginning, as a gentle robot that knows how to hold you safely and comfortably under any conditions that may be encountered.

*Goal: zero passenger deaths.*

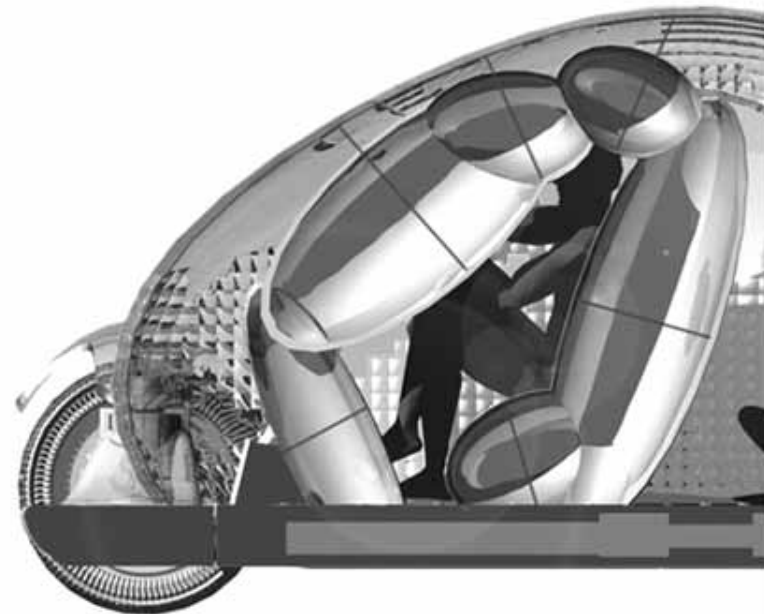

# quick review in- wheel suspension

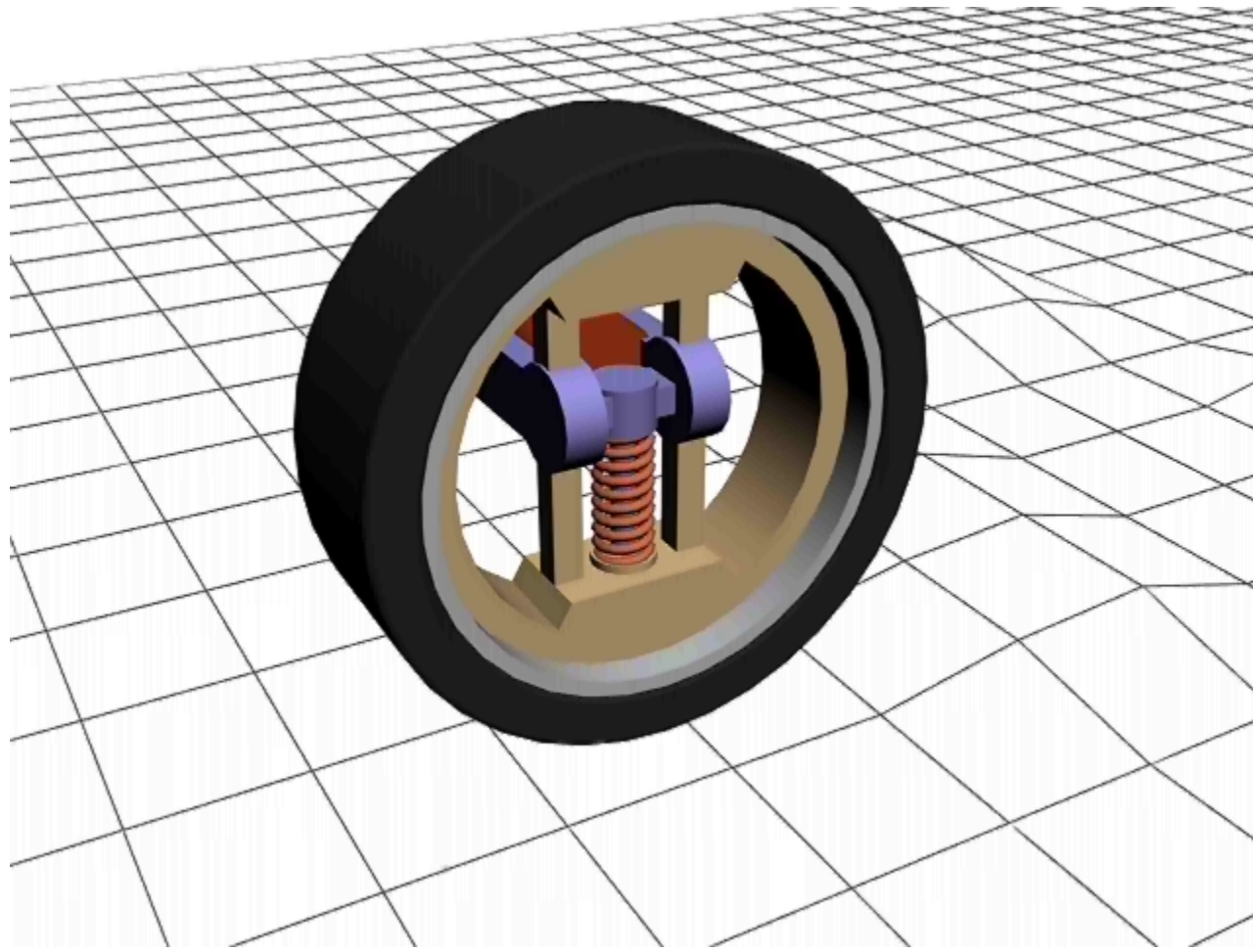

# quick review in- wheel suspension

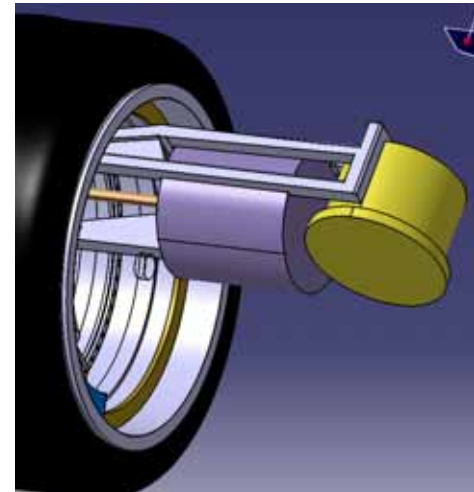
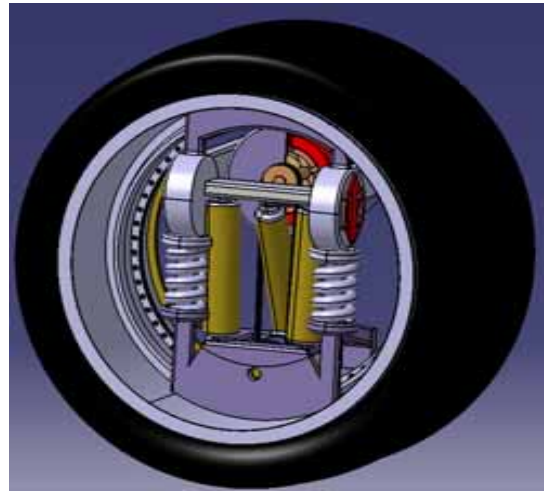
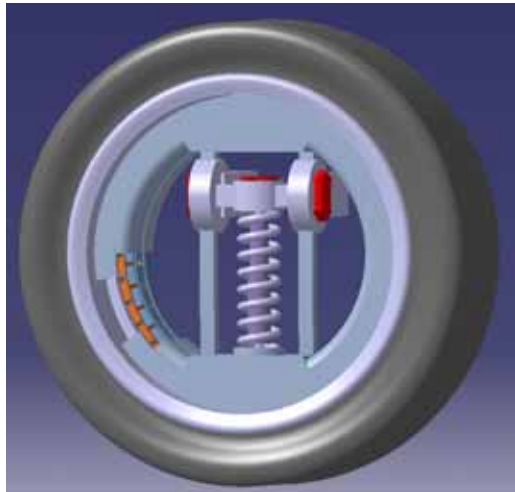



# running prototype #1- a summer's work

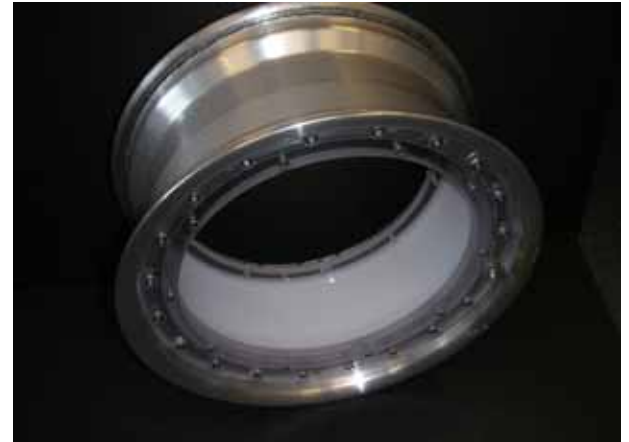

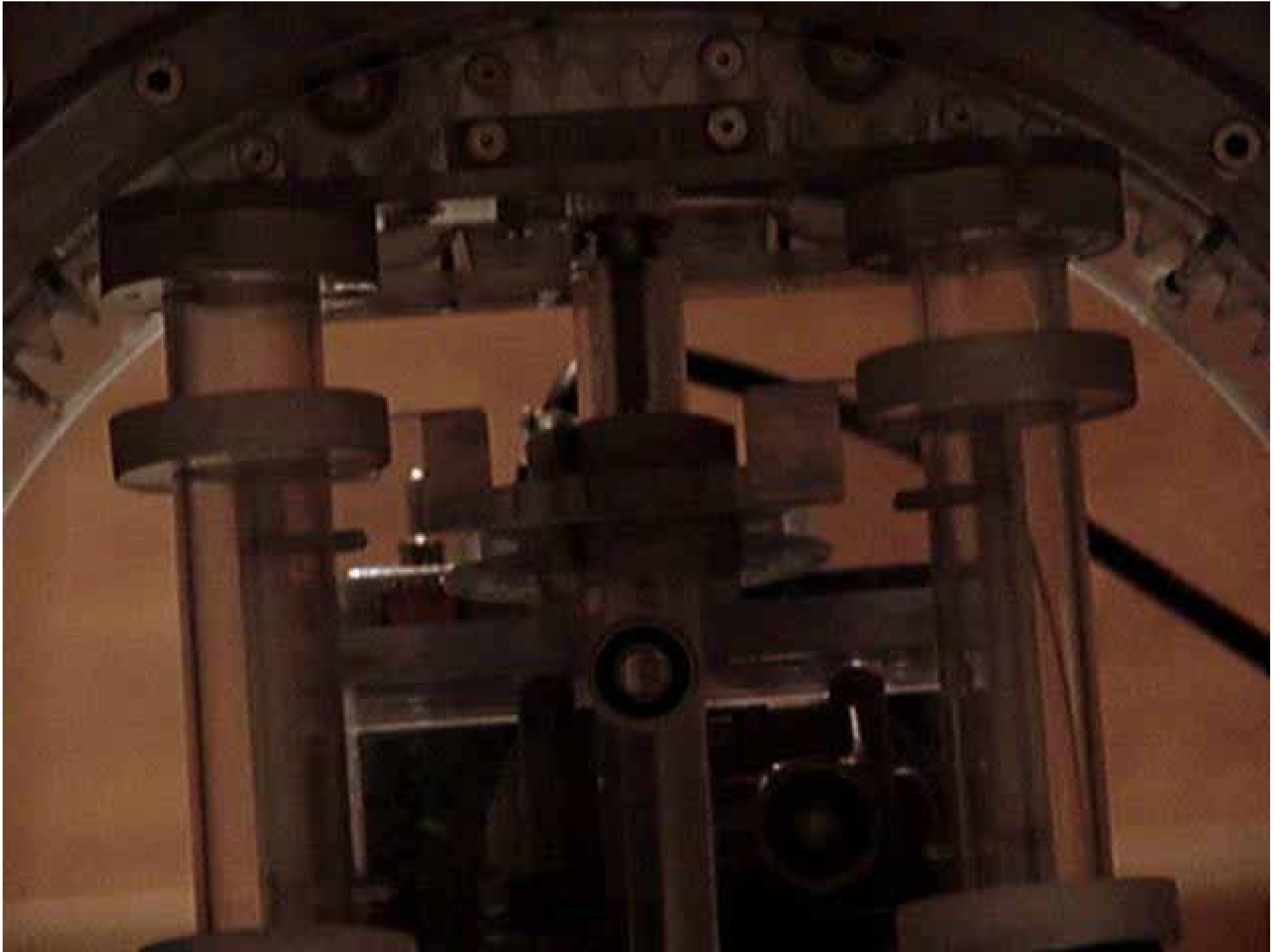







SOFT\_Car





CAR\_SOFT

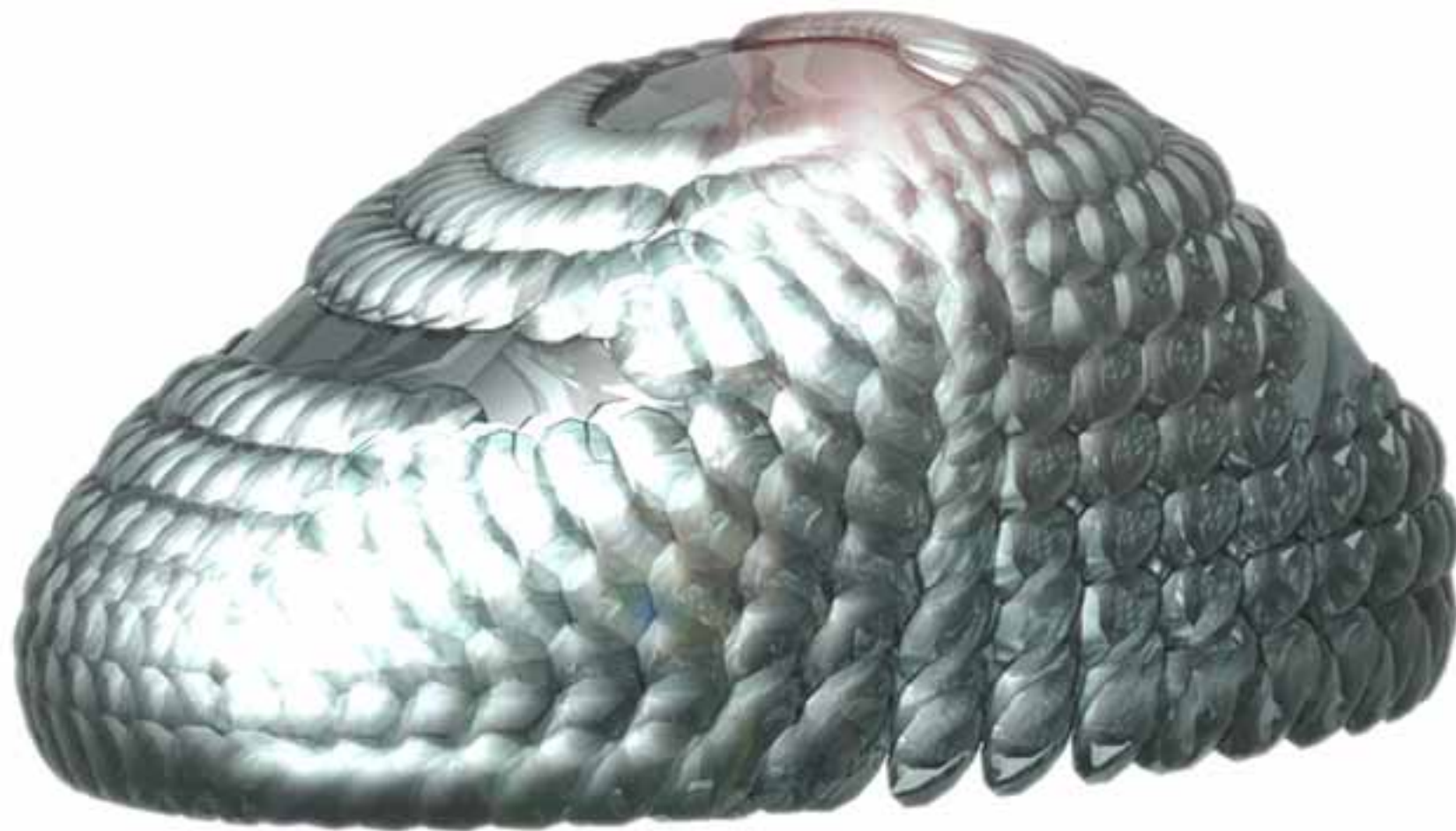



CAR\_SOFT

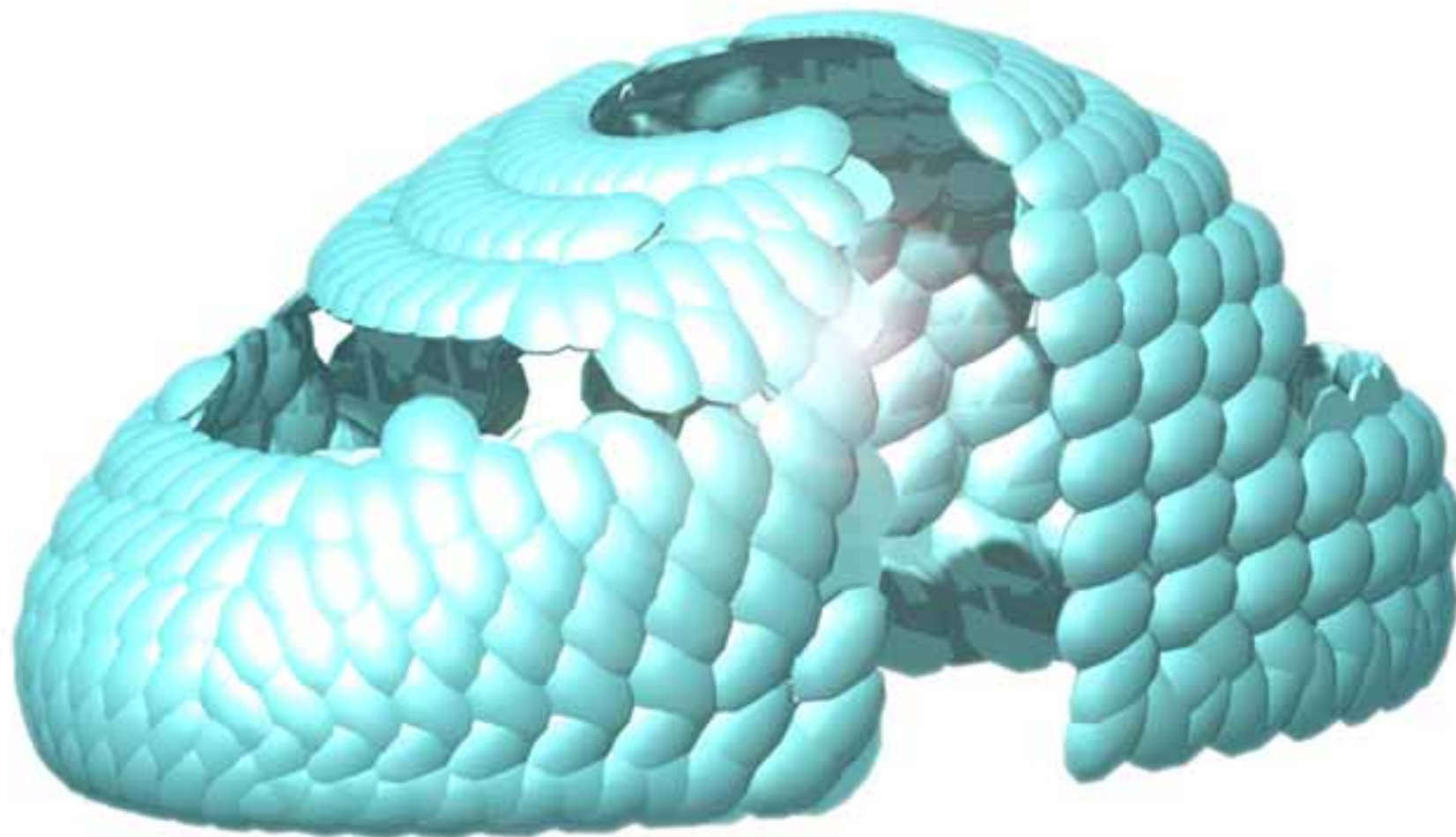

The Blahnik

/ Axel Kilian

Material Spring  
Side Ingress/Egress  
Front arms – Dynamic Cabin



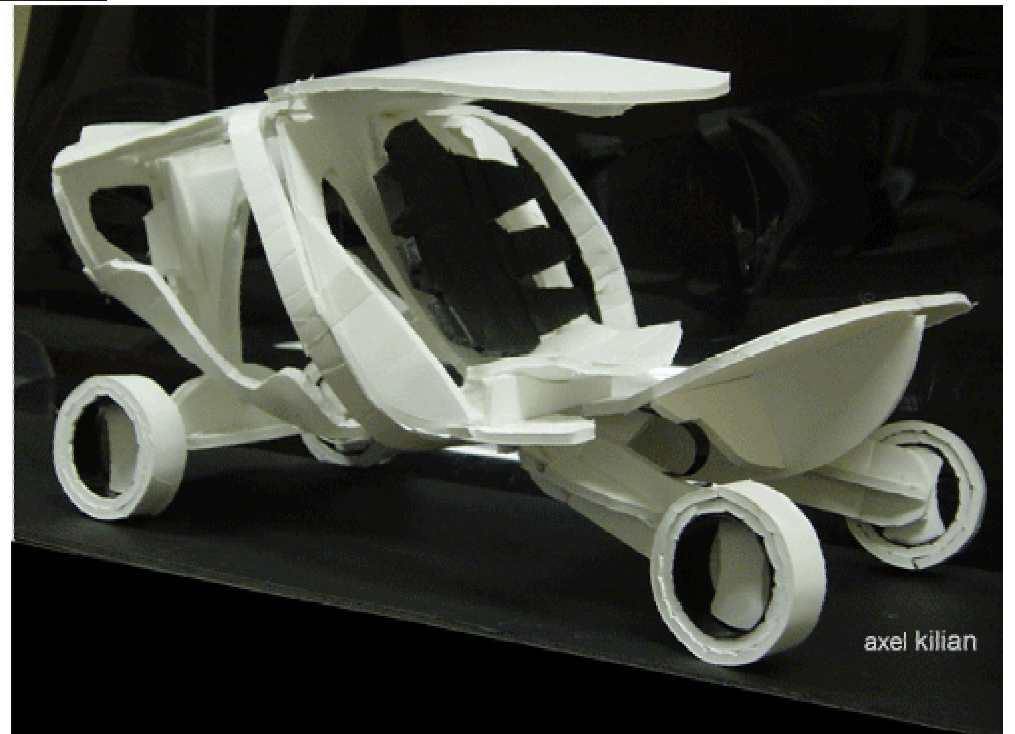
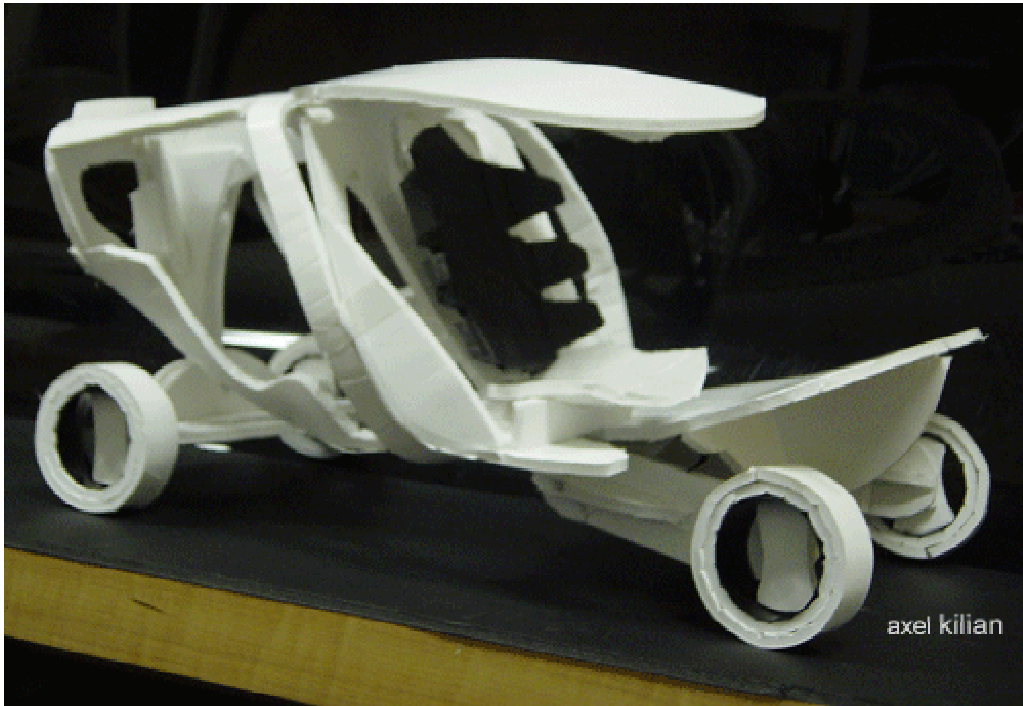

The Basket case / Will Lark

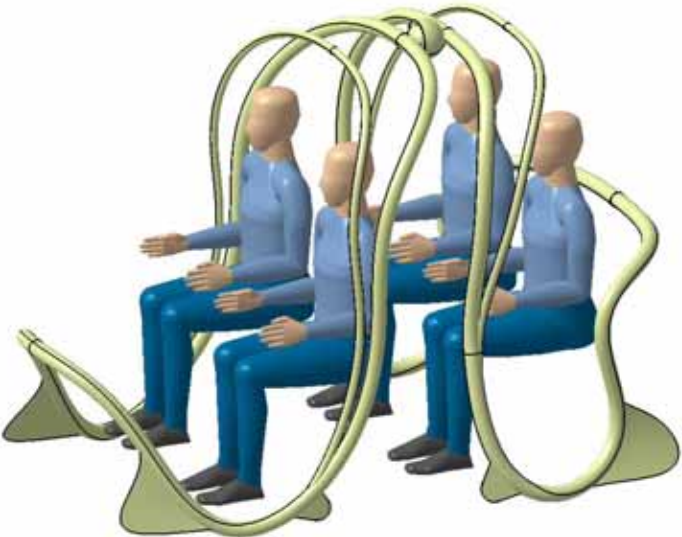
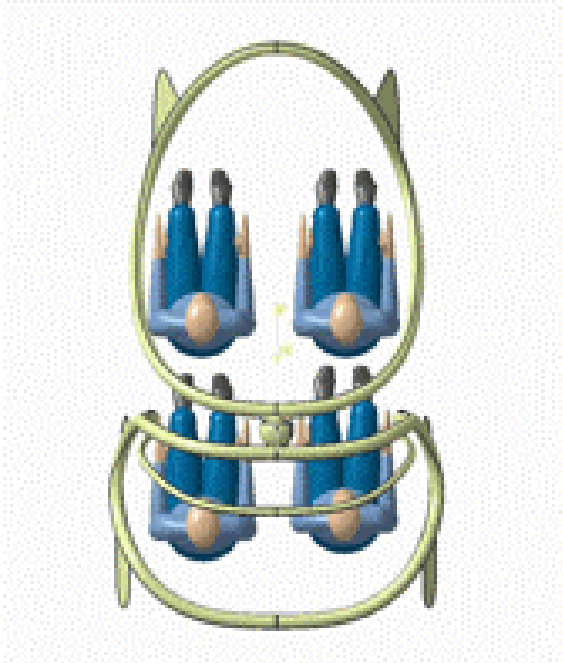
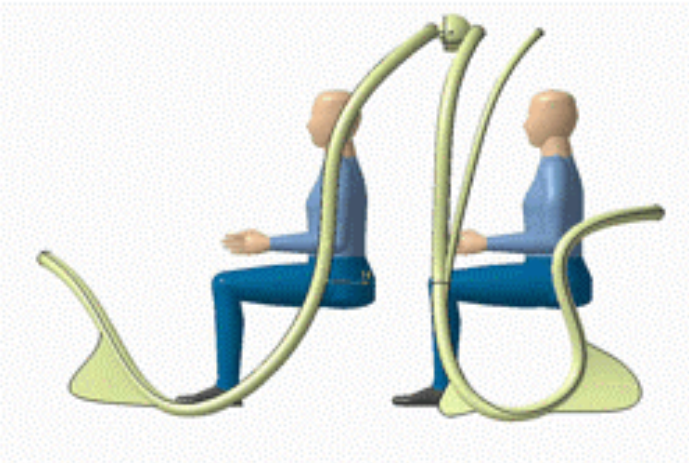

Dampening material placed between frame  
Side & front Ingress/Egress  
Twisting & Rocking frame – Dynamic Cabin



The Basket case / Will Lark



The Gator

/ Will Lark

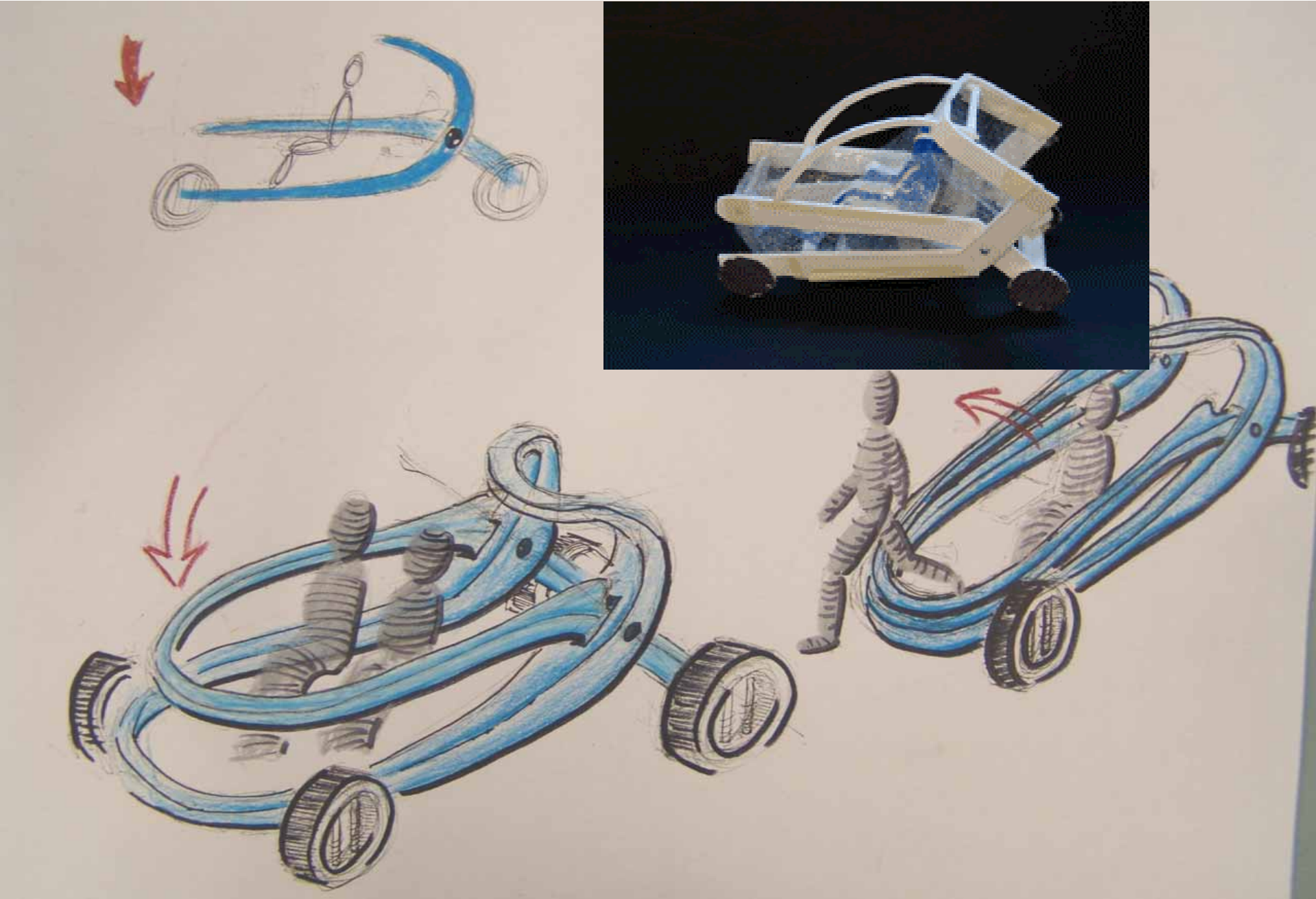

















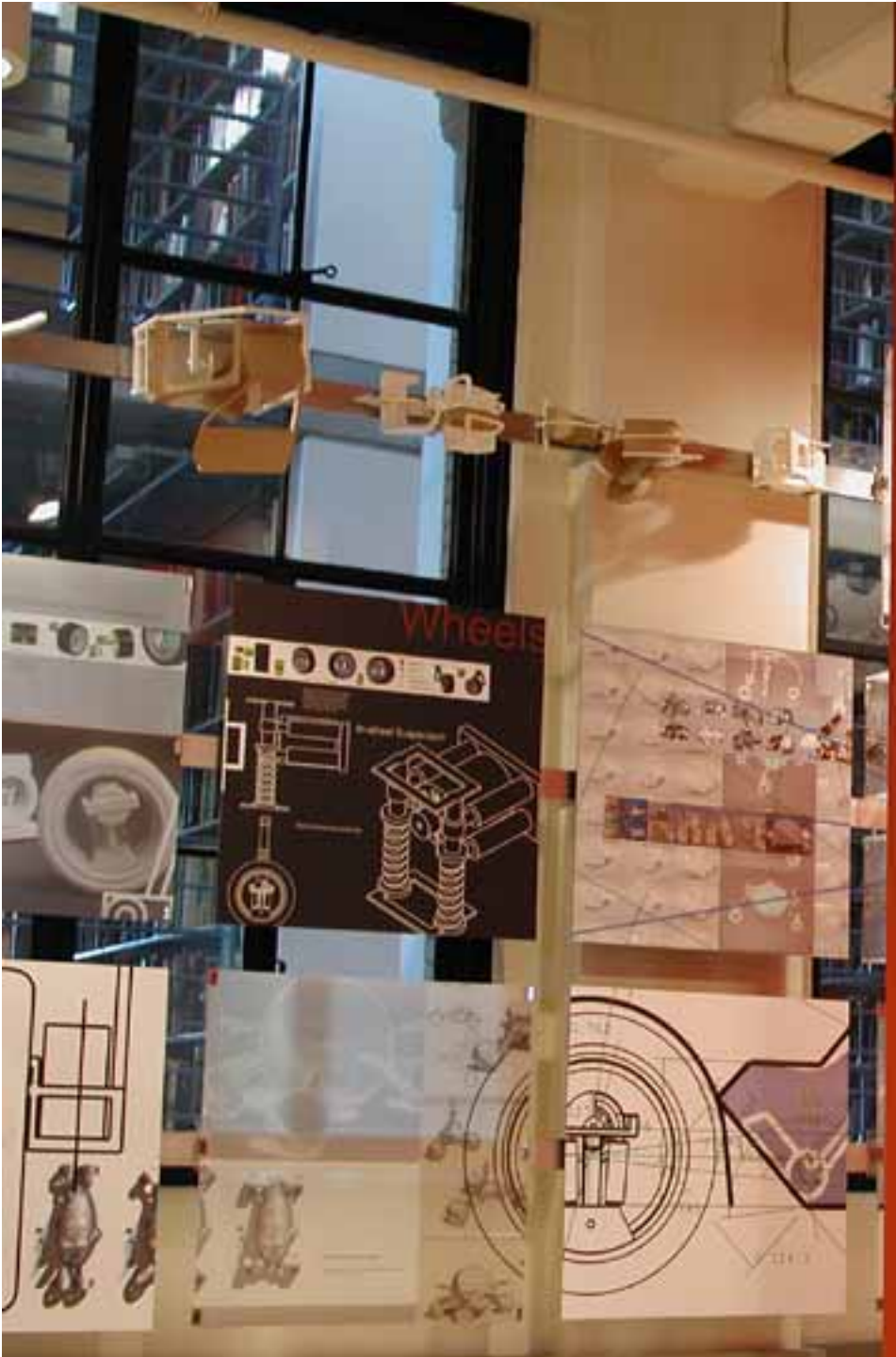



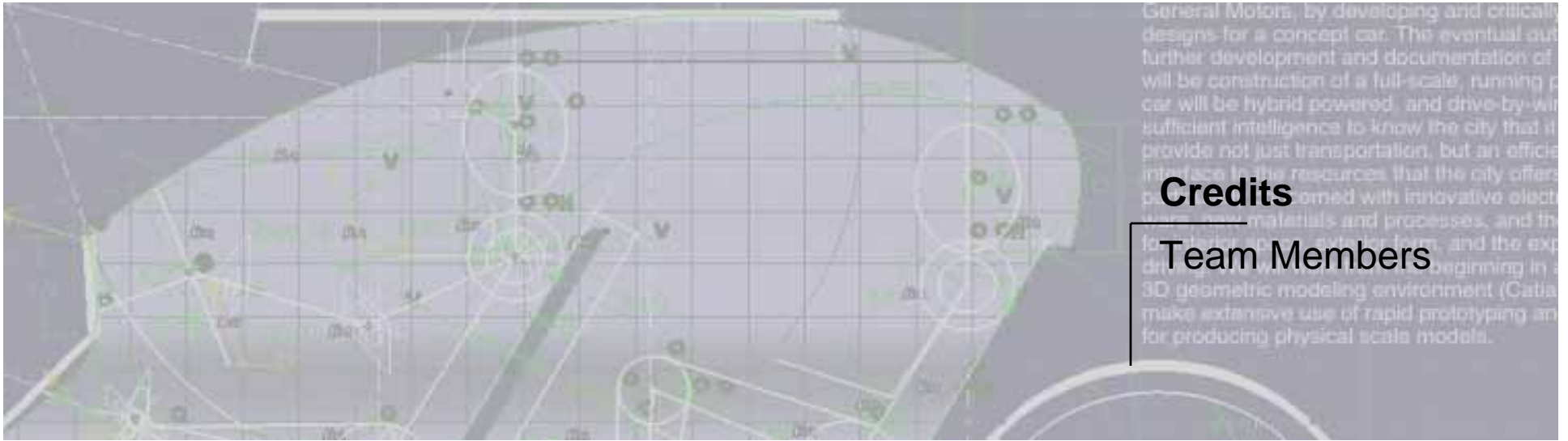

General Motors, by developing and critically designs for a concept car. The eventual further development and documentation of will be construction of a full-scale, running car will be hybrid powered, and drive-by-wire sufficient intelligence to know the city that it provide not just transportation, but an efficient interface to the resources that the city offers. The car is designed with innovative electronic materials and processes, and the focus is on the design, and the experience of driving. The beginning in a 3D geometric modeling environment (Catia) make extensive use of rapid prototyping and for producing physical scale models.

## Credits

## Team Members

### Instructors

William J. Mitchell  
James Glymph  
Frank O. Gehry

### Studio Coordinator

Ryan Chin

### Course Administrator

Betty Lou McClanahan

### Course Collaborators

James Gips  
Axel Kilian  
Franco Vairani  
Steven Smith

### Collaborative Research

Federico Casalegno  
Han Hoang  
Nikki Pfarr

### Students

Robyn Allen  
Louis Basel  
Marcel Botha  
Luis Berrios-Negron  
Darren Chang  
Brian Chan  
Chad Dyner  
Victor Gane  
David Gerber  
Jonathan Gips  
Joshua Goldwitz  
Ziga Ivanic

Mitchell Joachim  
Sotirios Kotsopoulos  
Patrik Künzler  
Ashwani Kumar  
Will Lark  
Philip Liang  
Yanni Loukissas  
Anmol Madan  
Raul-David Poblano  
Olumuyiwa Oni

Christianna Raber  
Andres Sevtsuk  
Peter Schmitt  
David Spectre  
Maya Turre  
Conor Walsh  
Tiffany Yang  
Giampaolo Zen