

Astr 323: Extragalactic Astronomy and Cosmology

Spring Quarter 2014, University of Washington, Željko Ivezić

Lecture 5:

Quasars and Active Galactic Nuclei

Outline

1. Introduction to Quasars and AGNs
2. Multi-wavelength Observations
3. The Unified AGN Model

Outline

1. Introduction to Quasars and AGNs

- what exactly is a Quasar/AGN and why do we care?
- brief history
- observational and physical characteristics

2. Multi-wavelength Observations

3. The Unified AGN Model

The Unified Model

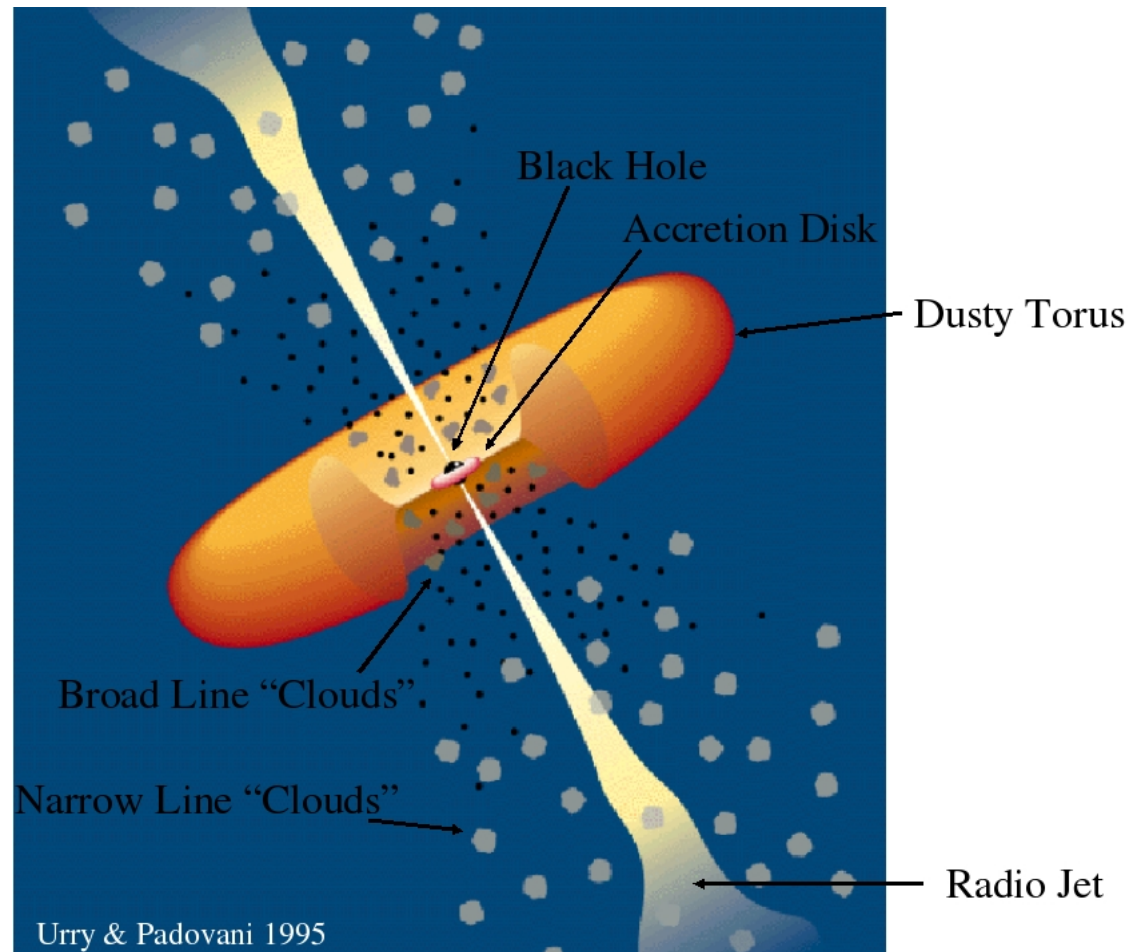

A quasar/AGN is a system in which accretion onto a supermassive black hole produces copious amounts of non-stellar radiation over the entire electromagnetic spectrum

What is a Quasar/AGN?

- A quasar/AGN is a system in which accretion onto a super-massive black hole produces copious amounts of non-stellar radiation over the entire electromagnetic spectrum
- Sometimes this light dwarfs the light from the galaxy itself!
- Quasars are high-luminosity analogs of AGNs: a quasar has $M_B < -23$ ($L_{bol} > 10^{11}L_{\odot}$). Quasars are typically seen as stellar (point) sources, while AGNs are seen as galaxies.
- Due to high luminosities, these objects are typically extremely distant (the most distant known quasar has a redshift of $> 7!$) and thus very old.

Why do we care?

We care about quasars and AGNs because:

- they are extremely interesting astrophysical “laboratories” (in particular, they play a crucial role in the studies of black holes)
- they are excellent probes of the early Universe (“powerful lighthouses”), and of everything between us and them (e.g. intergalactic medium, dark matter in galaxies)

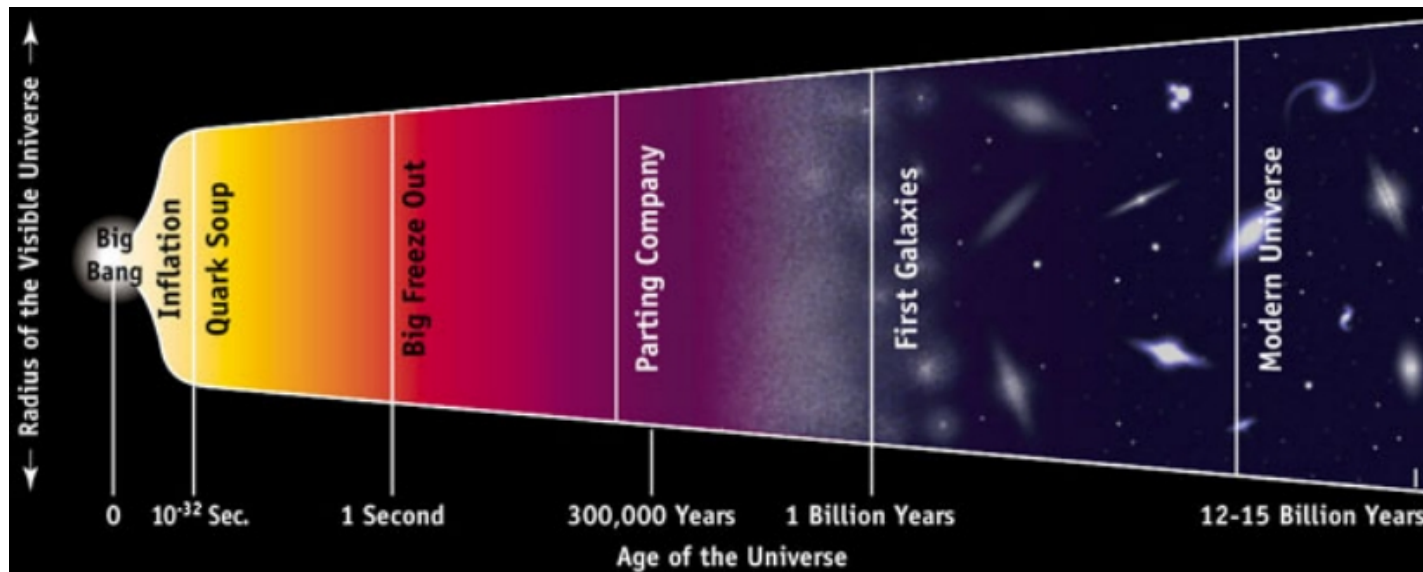

A quasar is a galaxy in which accretion onto a supermassive black hole produces copious amounts of non-stellar radiation over the entire electromagnetic spectrum; this light dwarfs the light from the galaxy itself.

$$L \sim 10^{43-46} \text{ ergs/s}$$

$$M \sim 10^{6-9} M_{\text{sun}}$$

Quasar = active galactic nuclei = AGN = Seyfert etc.

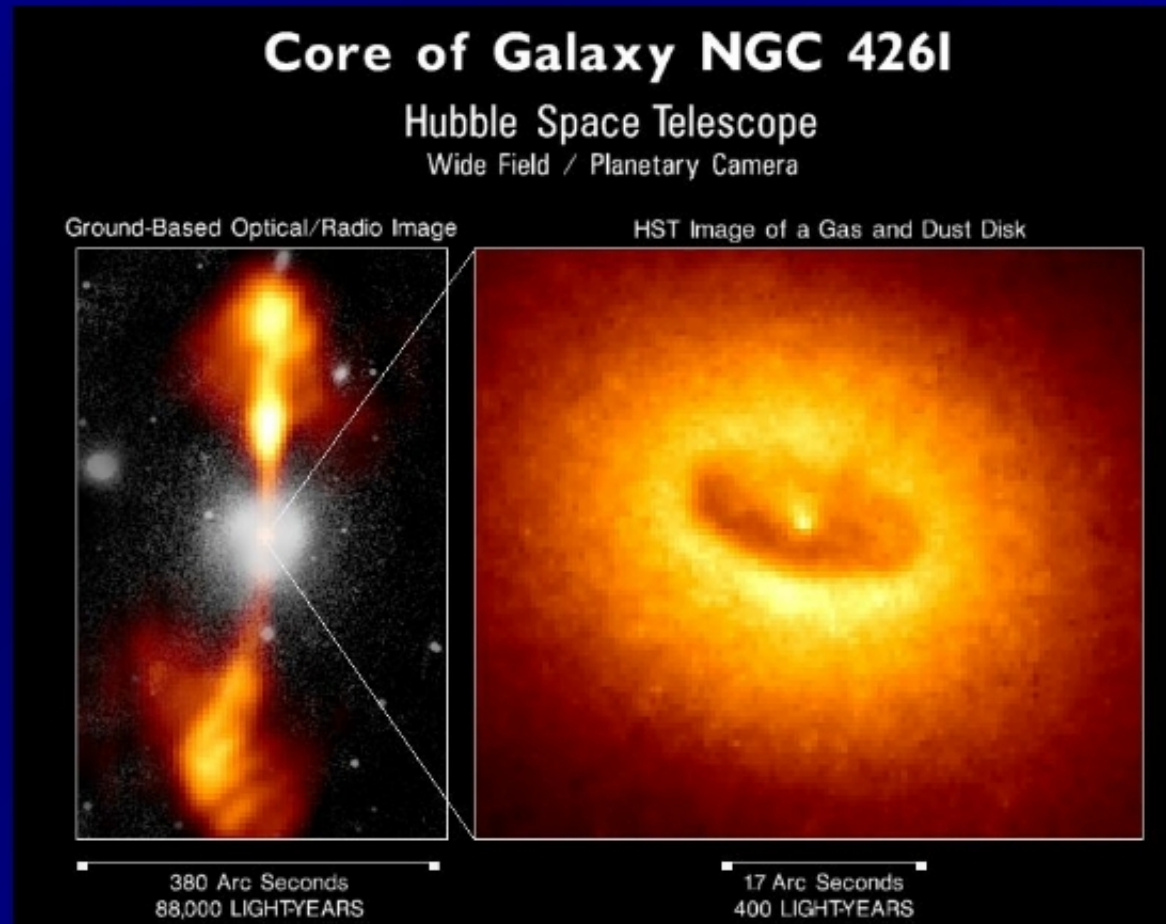

Observational Characteristics

Composite Optical/UV Quasar Spectrum

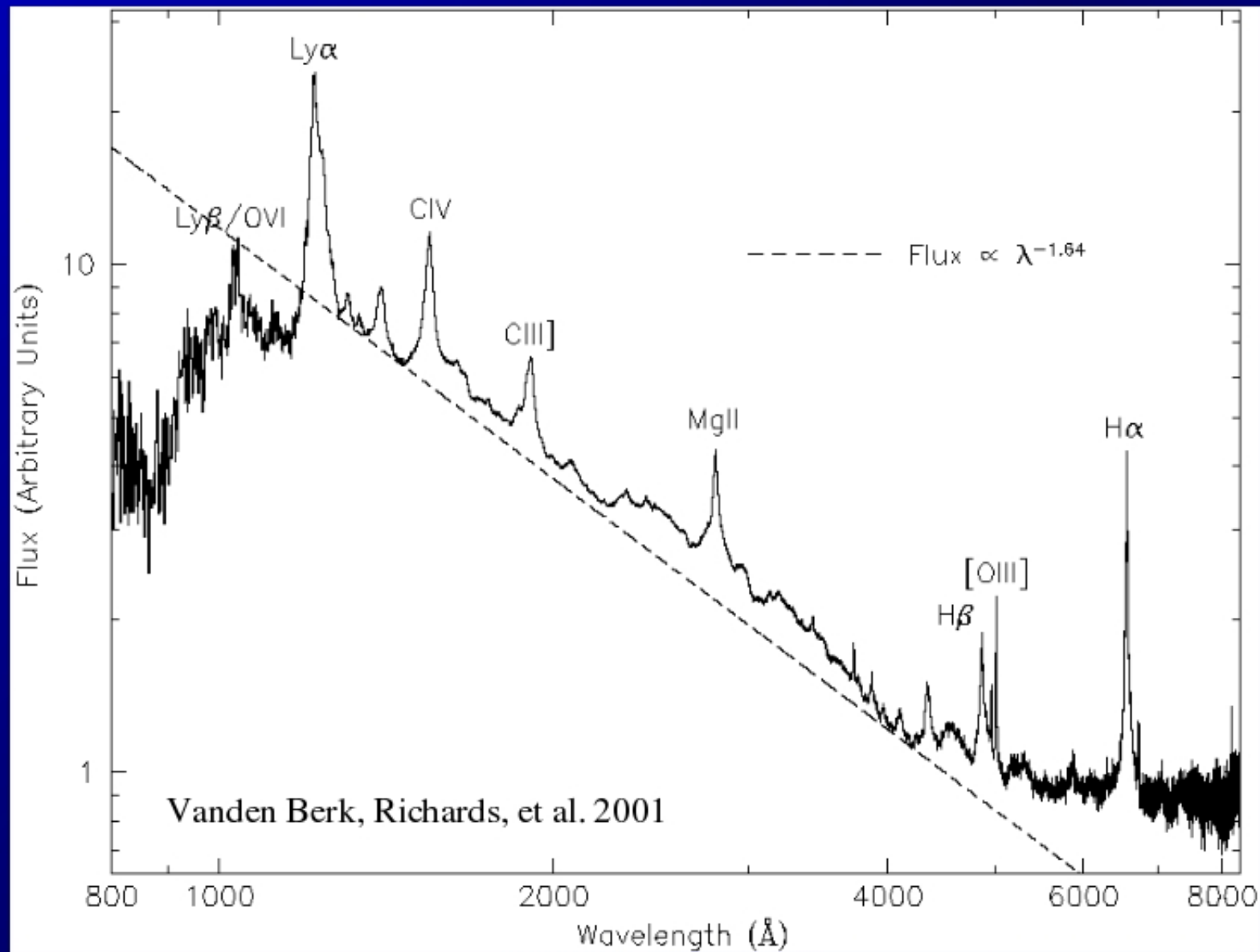

Spectra of thousands of SDSS quasars
added together

The Broad and Narrow Line Regions

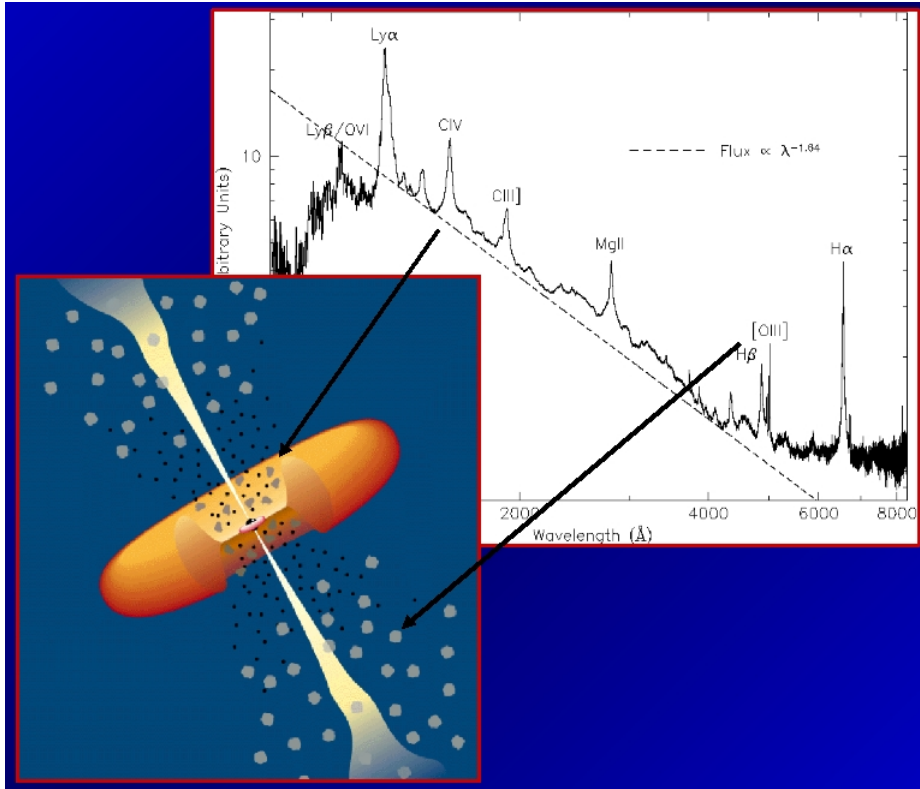

- It is expected that higher velocity/broader lines come from gas that is closer to the “central engine” (remember the virial theorem from Lecture 3?)

- Spectral lines come in two types: “broad” (1,000–10,000 km/s) and “narrow” (100–1,000 km/s). Practically all objects show narrow lines, but only some have broad lines.
- The presence of broad lines indicates that we can see high-velocity gas. These objects are known as **“Type 1” AGN** (e.g. Seyfert 1s and type I quasars)
- The absence of broad lines indicates that we cannot see high-velocity gas – either because it is obscured (perhaps by the molecular torus, motivation for the Unification Model), or because it is simply not there. These objects are called **‘Type 2’ AGN**

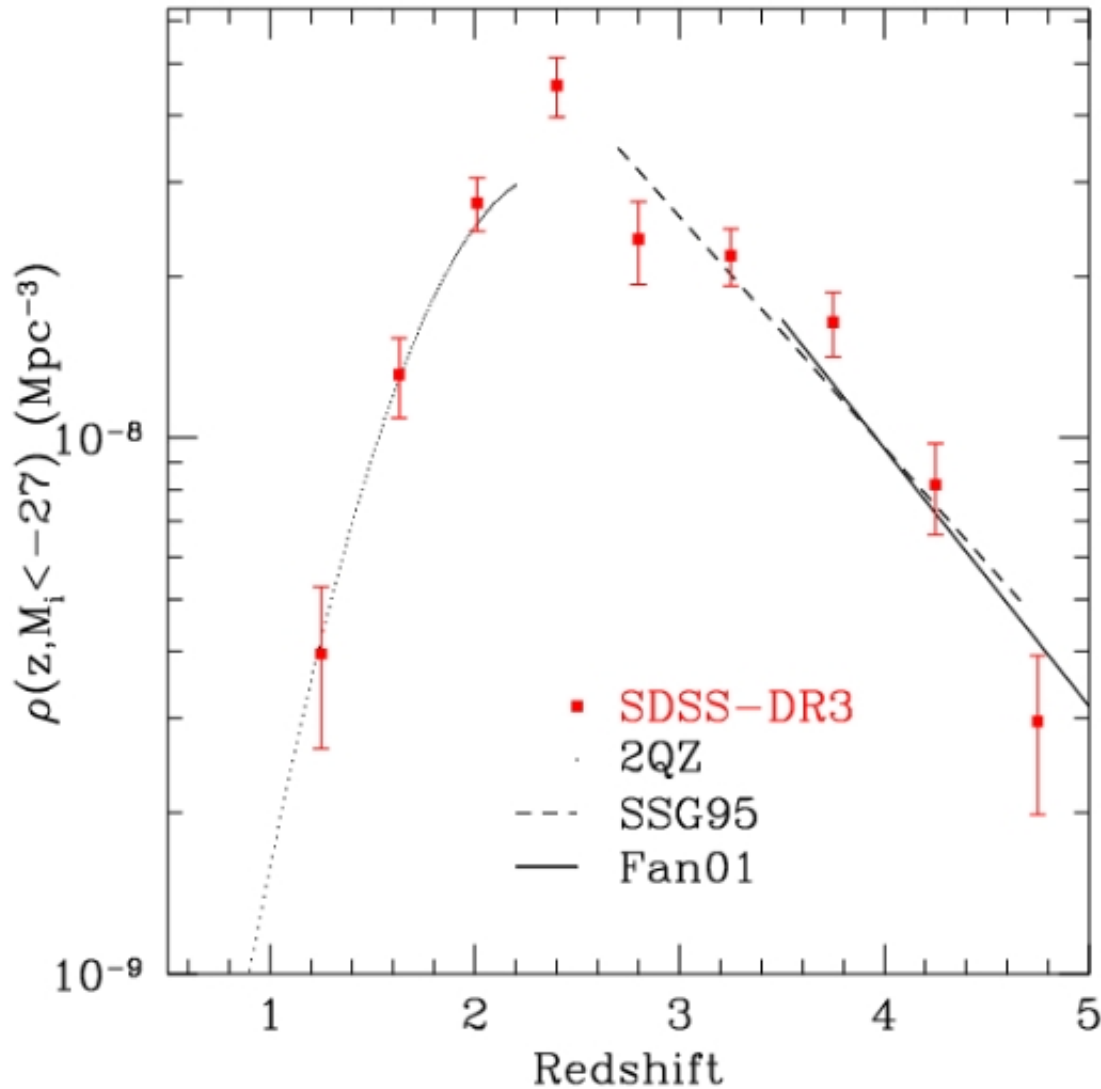

The Quasar Era

- The quasar density was the highest at redshift ~ 2.2 , and at the 5% level of the maximum density between redshifts ~ 1.2 and ~ 6
- These redshifts imply that the quasar density was the highest when the age of the Universe was 1/4 of its present age, and that it was above 5% of the maximum density when the age of the Universe was between 5% and 50% of its present age.
- The first half of the age of the Universe was “the era of quasars”

Quasar Luminosity Function

Space density of quasars as a function of redshift and luminosity

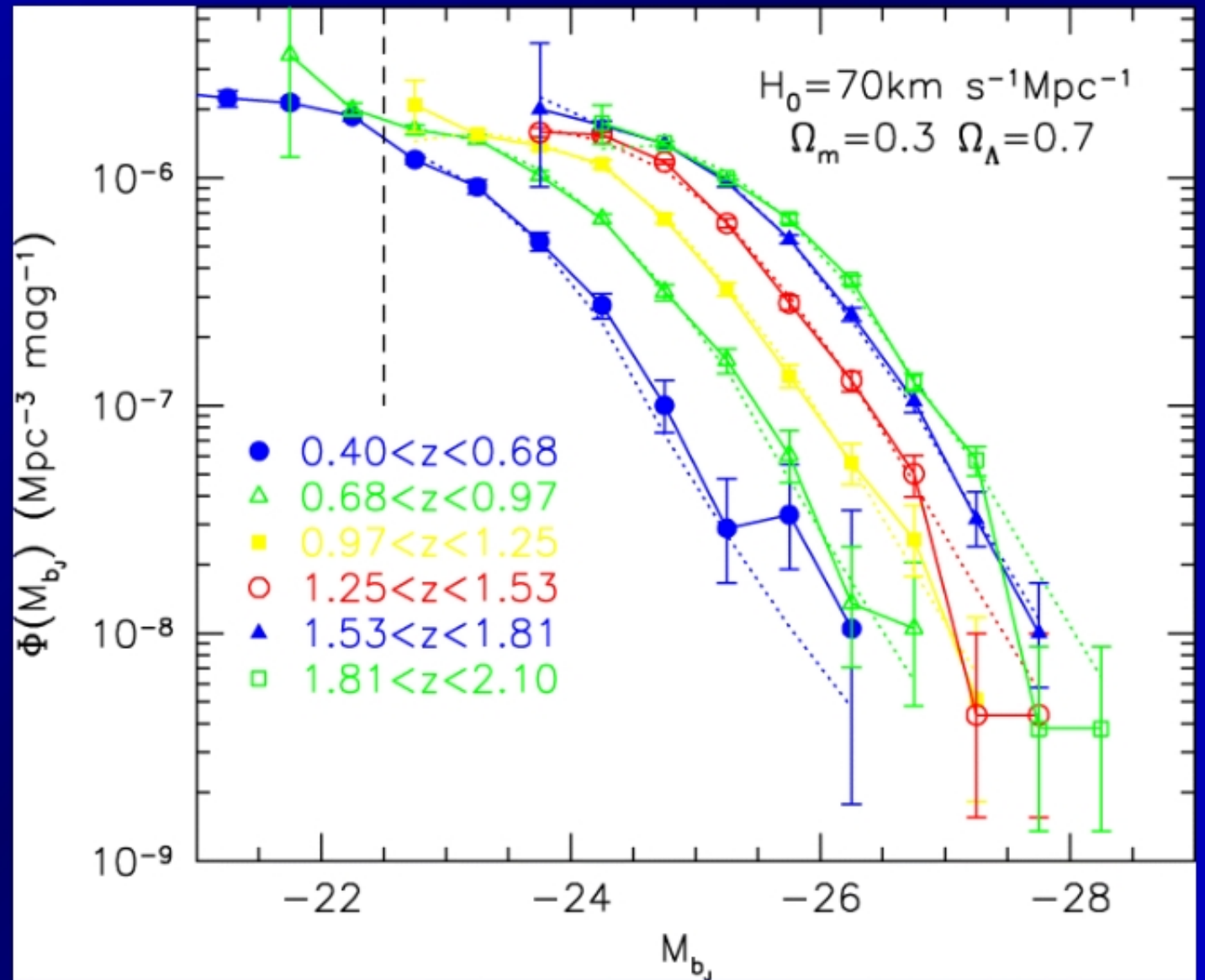

Croom et al. 2004

Quasar luminosity function depends on redshift (i.e. time)!

Quasars vs. AGNs

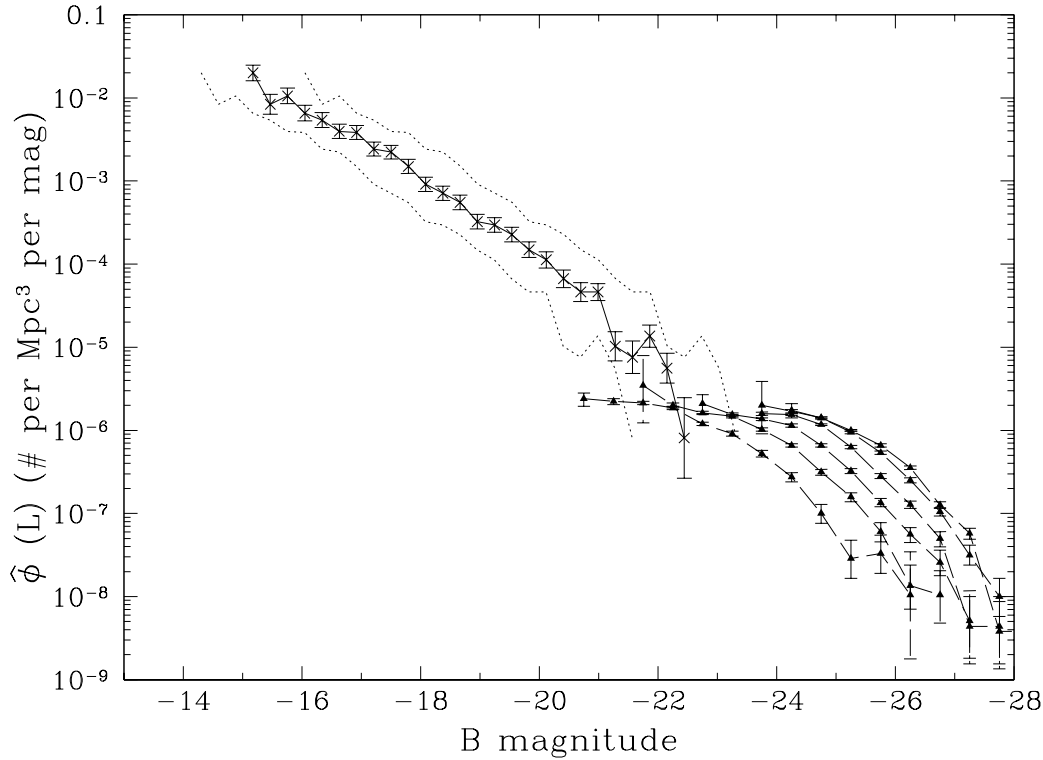
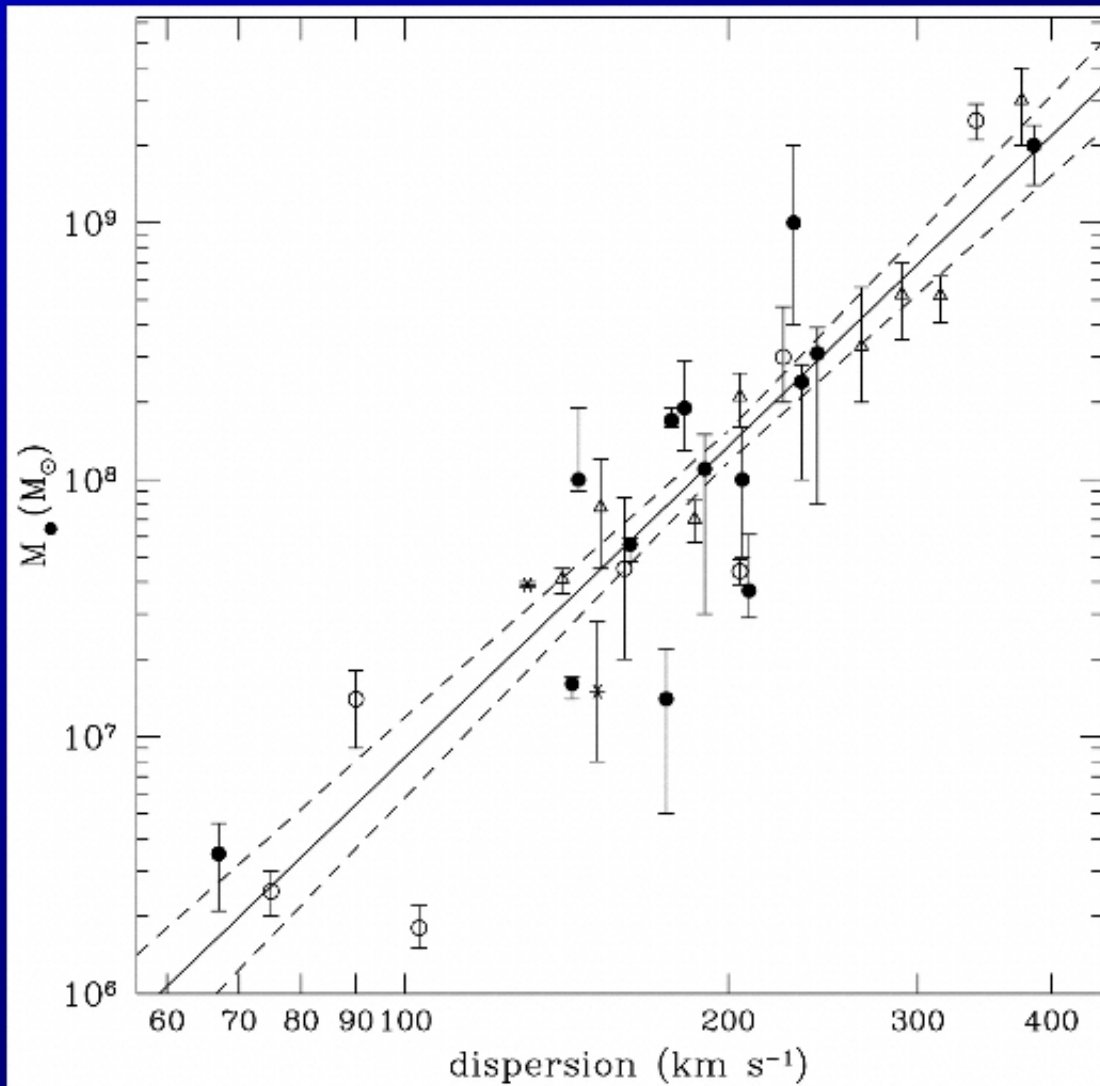

Fig. 13.— Our converted B band magnitude luminosity function, compared with the 2dF quasar luminosity function. Our luminosity function is converted to $H_0 = 70\text{km/sMpc}^{-1}$. From left to right, the different 2dF quasar luminosity functions are for the redshift range: $0.40 < z < 0.68$, $0.68 < z < 0.97$, $0.97 < z < 1.25$, $1.25 < z < 1.53$, $1.53 < z < 1.81$ and $1.81 < z < 2.10$ respectively. At luminosities fainter than $M_B = -22.5$, the 2dF quasar luminosity function might suffer significant incompleteness due to the effect of the host galaxy, therefore the comparison should be made only for luminosities brighter than $M_B = -22.5$.

- Lower-luminosity AGNs morphologically appear as galaxies; can be recognized using emission line ratios (BPT diagram)
- The two types of sources are thus selected and studied in **very** different ways – are the data consistent with our belief that they are similar phenomena that only differ by luminosity?
- Lao et al. (2004): **the luminosity function for AGN galaxies is consistent with the quasar luminosity function!**

The M_{BH} -sigma Relation

Massive black holes **co-evolve** with their host galaxies.



(Tremaine et al. 2002; also Ferrarese & Merritt 2000; Gebhardt et al. 2000; Magorrian et al. 1998)

Black holes know where they live!

Quasars and AGNs

1. Introduction to Quasars and AGNs
2. Multi-wavelength Observations
 - What do we see from X-rays to radio?
 - SDSS quasar survey
3. The Unified AGN Model

Quasar Spectral Energy Distribution

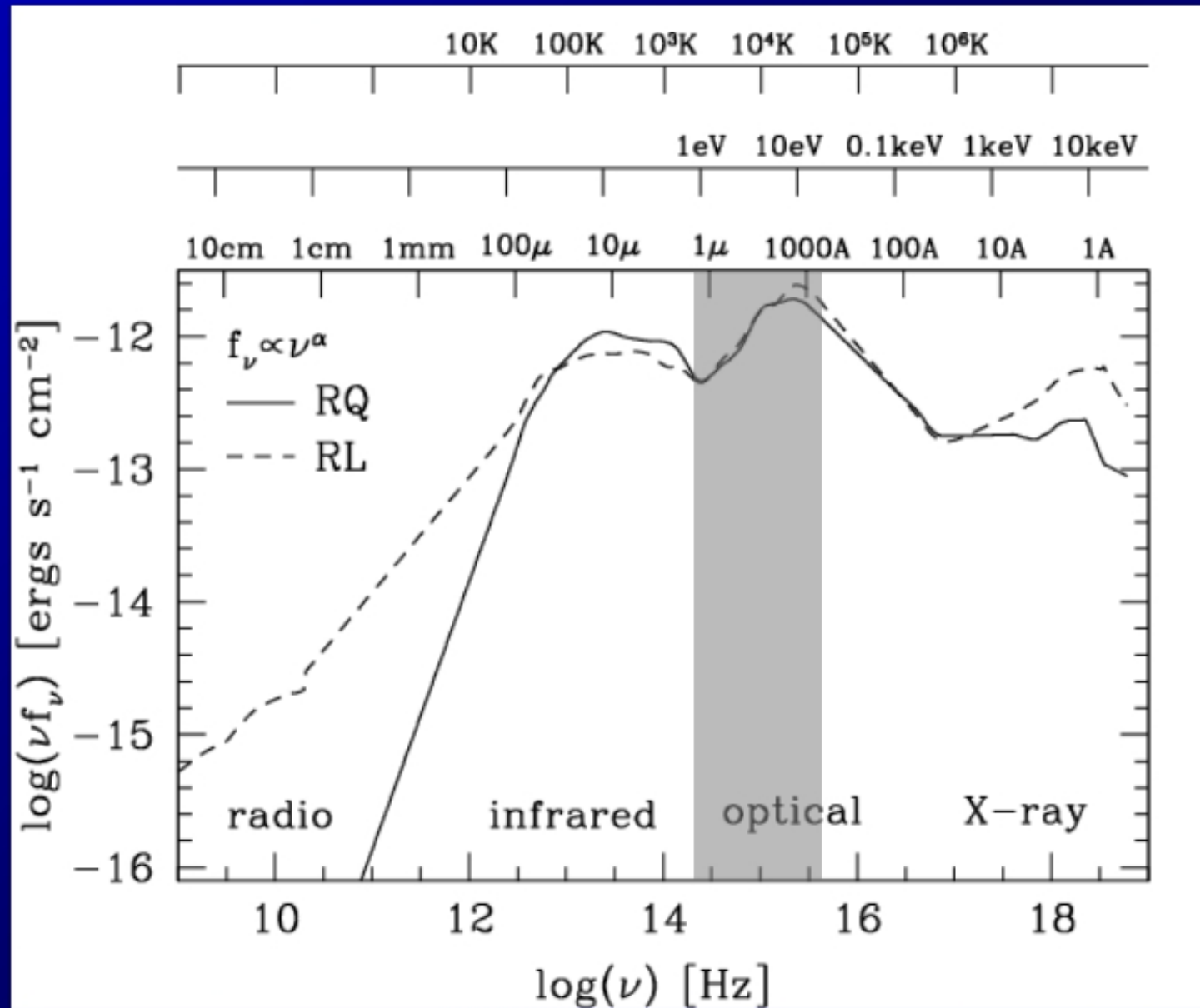

e.g., Elvis et al. 1994

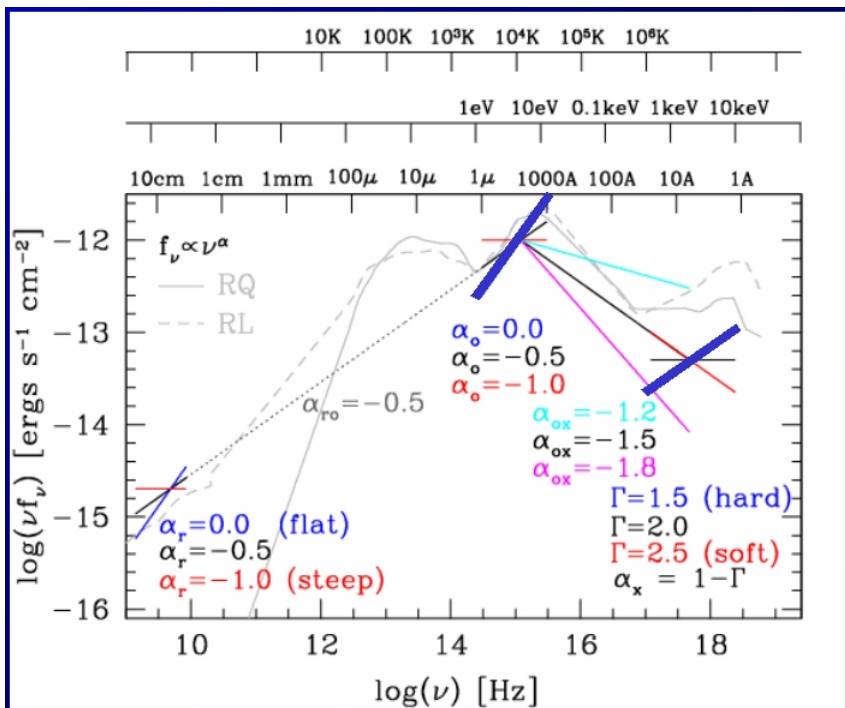

Important: Radiation in different spectral regions is emitted by different processes, and from different places in the quasar/AGN environment. Some radiation is thermal and some is not (e.g. radio synchrotron emission from jets); in general, the longer the wavelength, the larger is the distance of the emitting material from the center

Nomenclature

- Astronomers working in different spectral regions use different nomenclature for measuring spectral slope
- **Optical:** blue vs. red
- **X-rays:** hard (blue) vs. soft (red)
- **Radio:** flat (blue) vs. steep (red) (note that in the plot *flat* is not horizontal, and *steep* is flat – this is because the plot shows νF_ν , while these definitions are based on the behavior of F_ν)
- Additional measures of slope: α_{ox} (optical-to-X-ray slope) and α_{ro} (radio-to-optical slope), IR parameters...

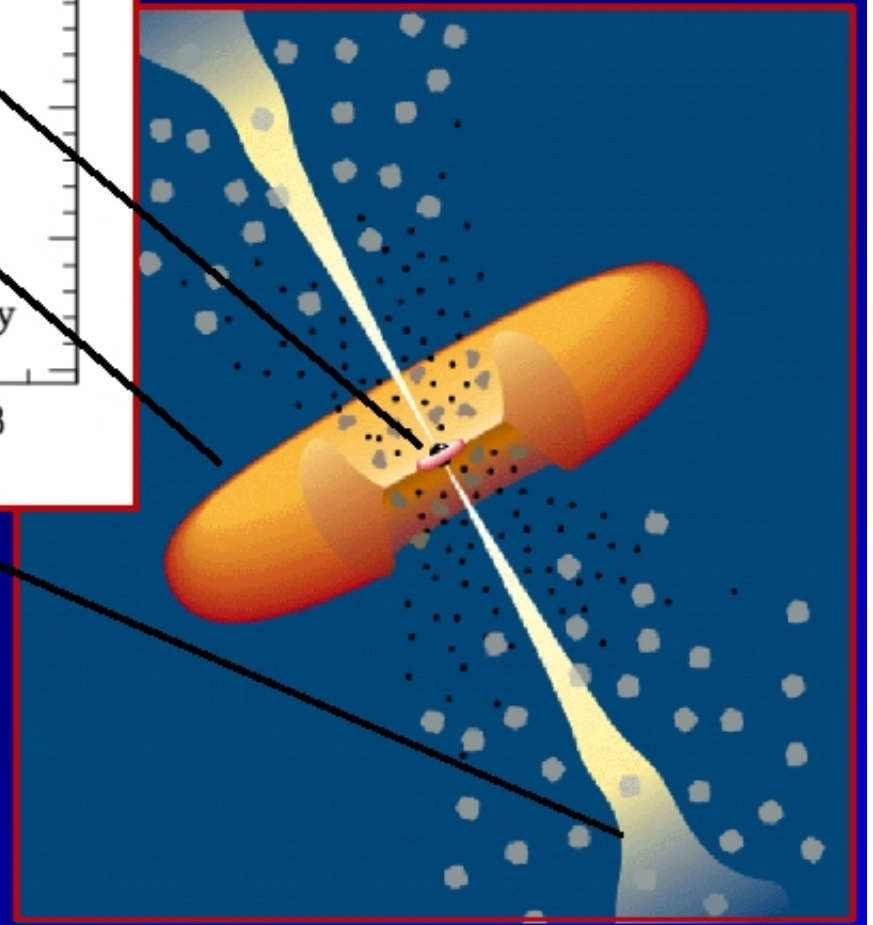
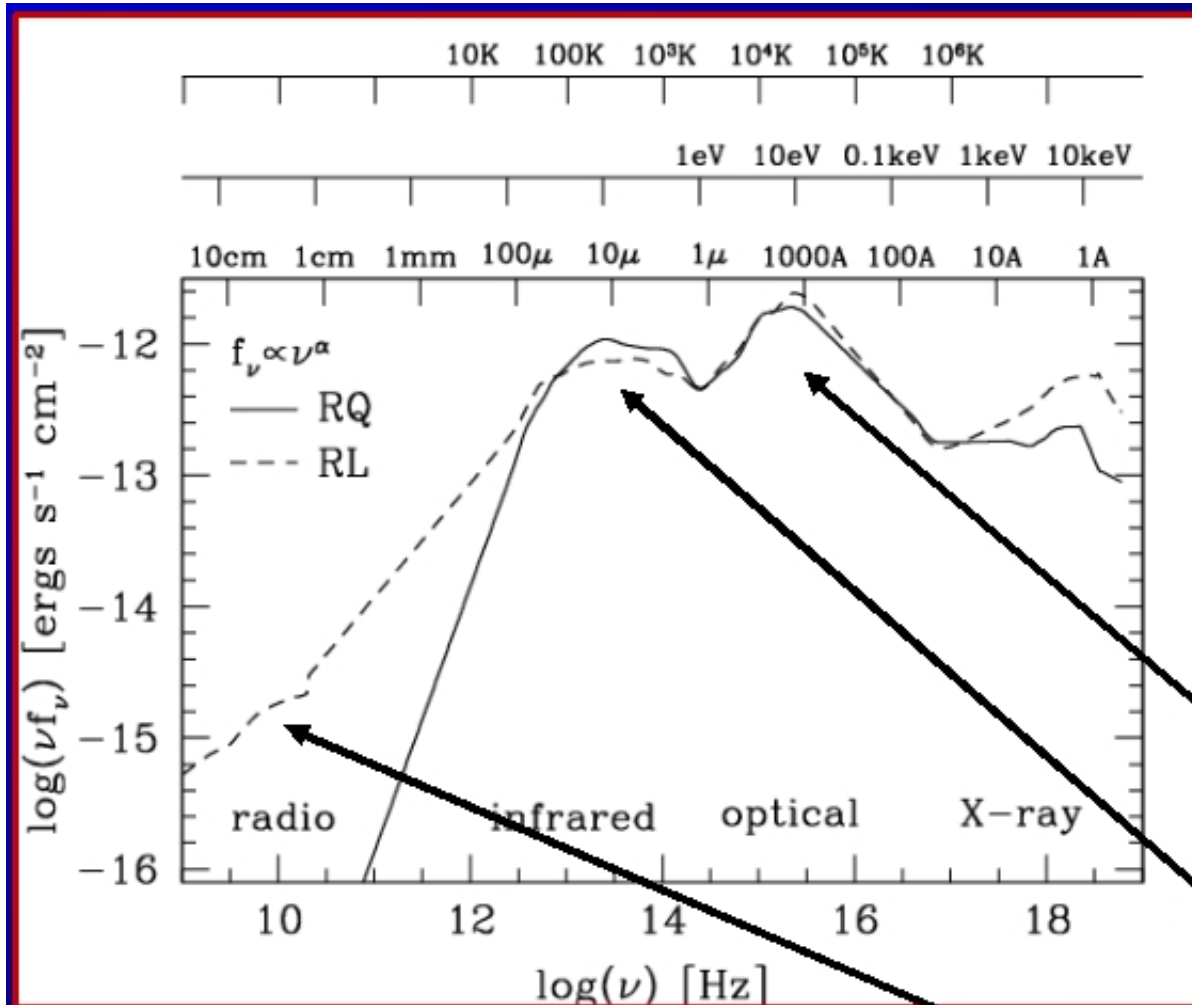

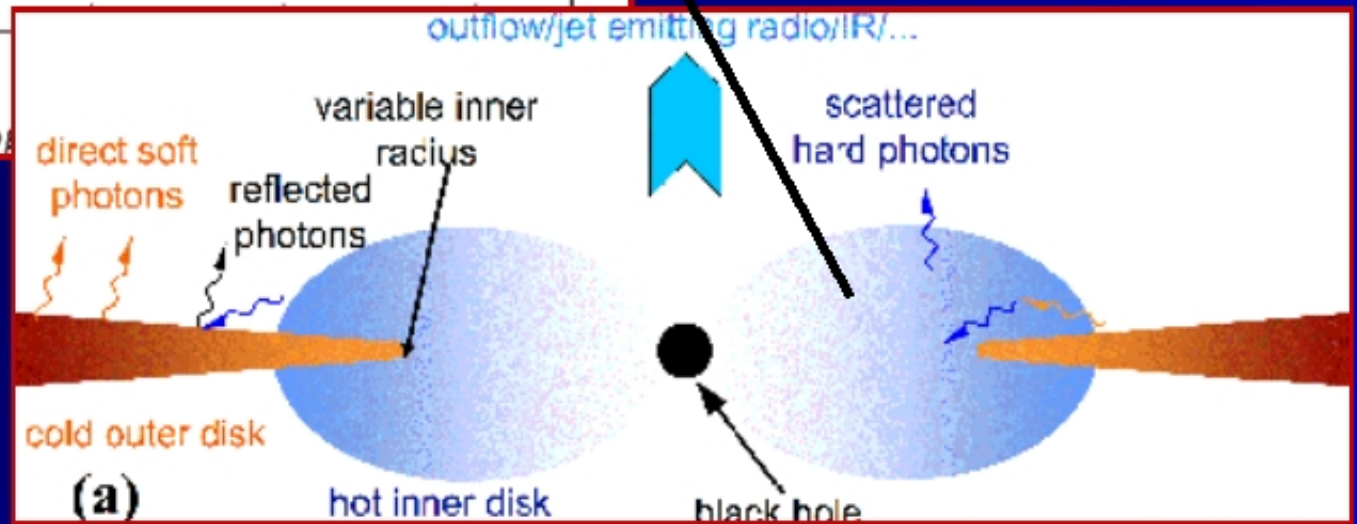
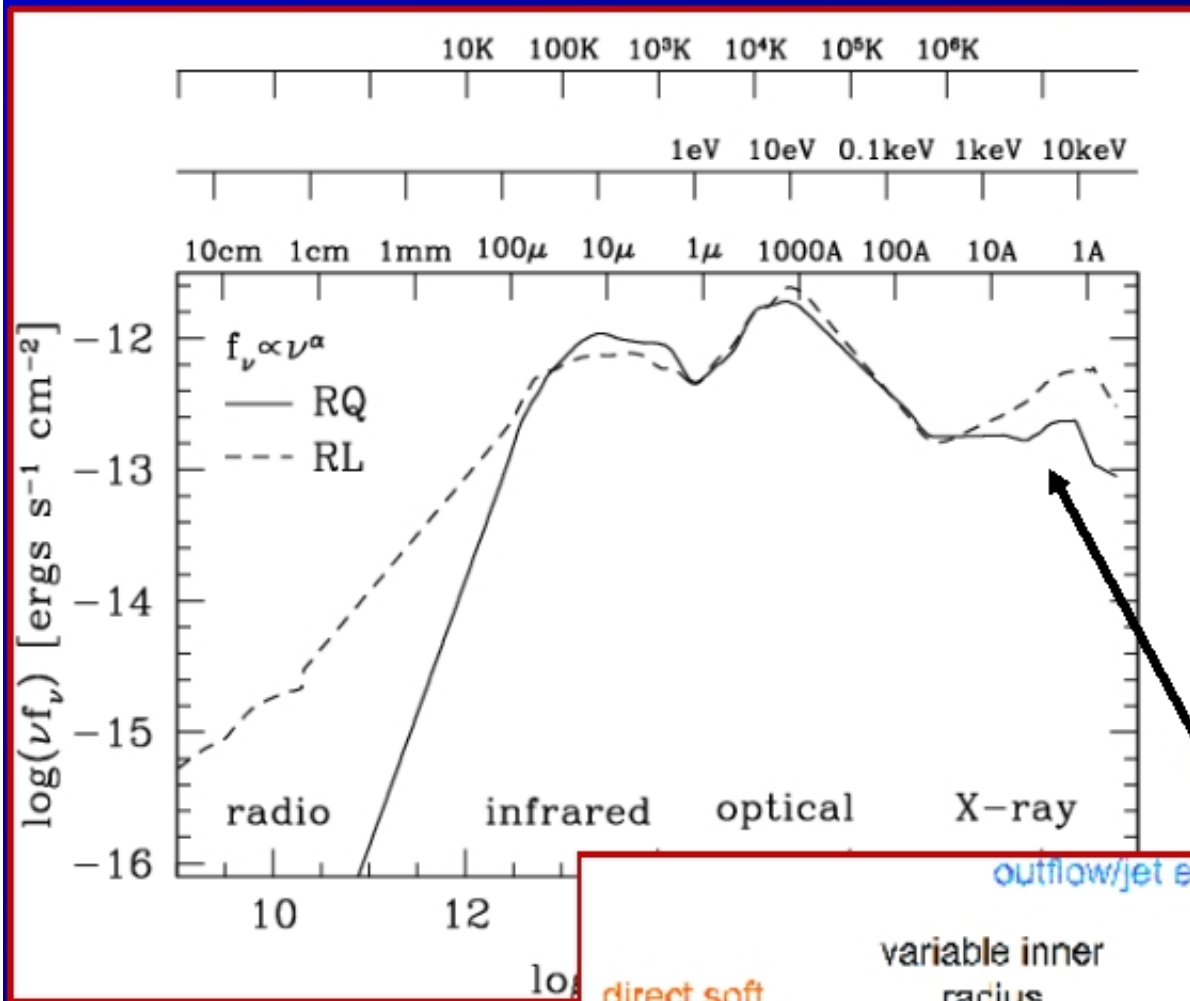

Zdziarski & Gierlinski 2004

Modern Era of Large Surveys at Many Wavelengths

- **SDSS**: UV-IR five-band photometry for 100 million galaxies and 1 million quasar candidates, spectra for 1 million galaxies and 100,000 quasars
- **2MASS**: near-IR (JHK) for 1.65 million resolved sources, and 471 million point sources
- **GALEX**: far-UV (2 bands: 0.12 and 0.22 μm), all-sky survey to $m_{AB} \sim 20.5$, 4 deg² to $m_{AB} \sim 26$, spectroscopy for $\sim 100,000$ galaxies, angular resolution 4-6 arcsec
- **ROSAT, Chandra, XMM**: X-rays (soft and hard), energetic processes, hard X-rays penetrate dust (important for AGNs)
- **IRAS, ISO, Spitzer**: dust emission, high-redshift sources
- **FIRST, NVSS, WENSS, GB6**: Radio surveys, good for AGNs

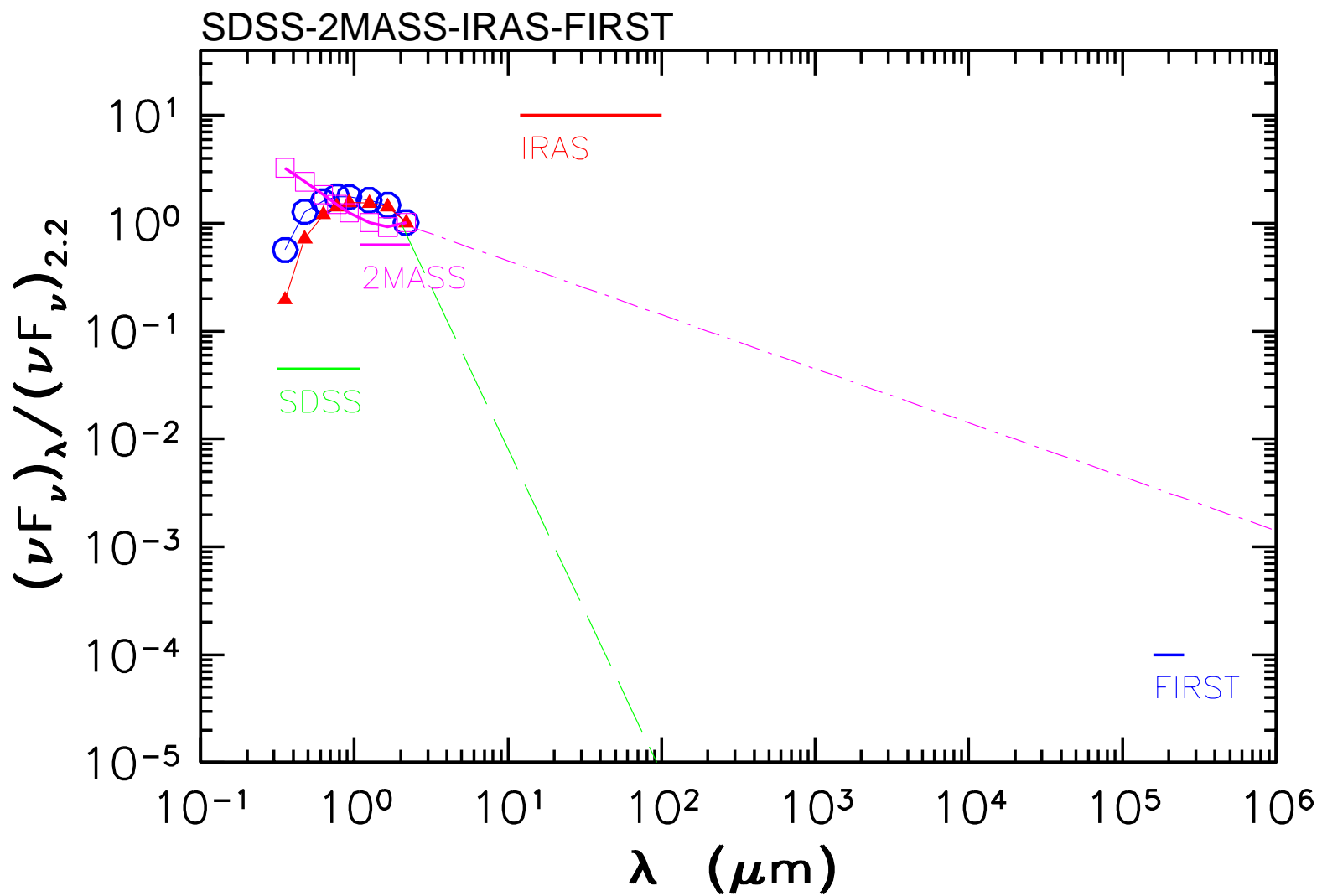

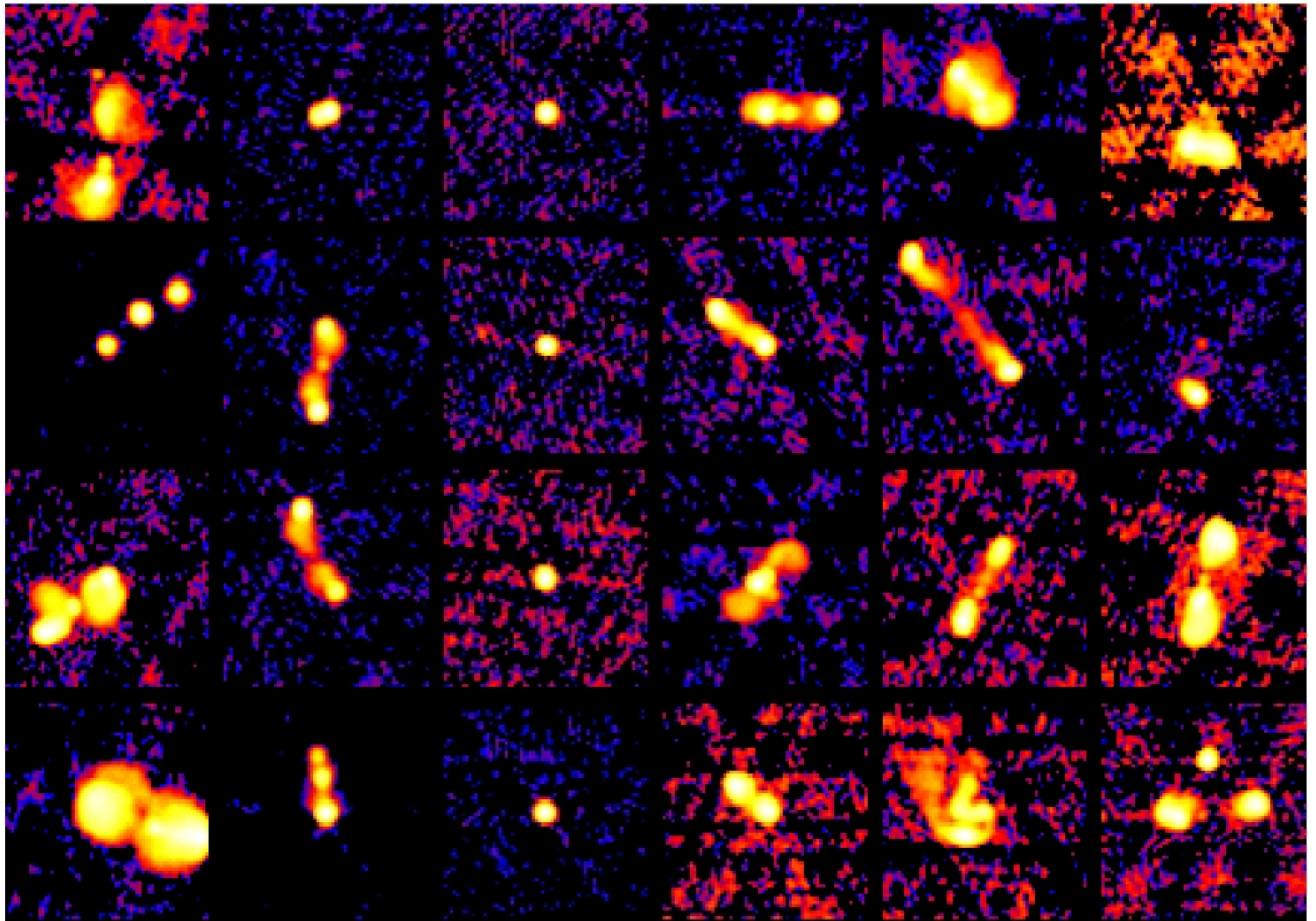

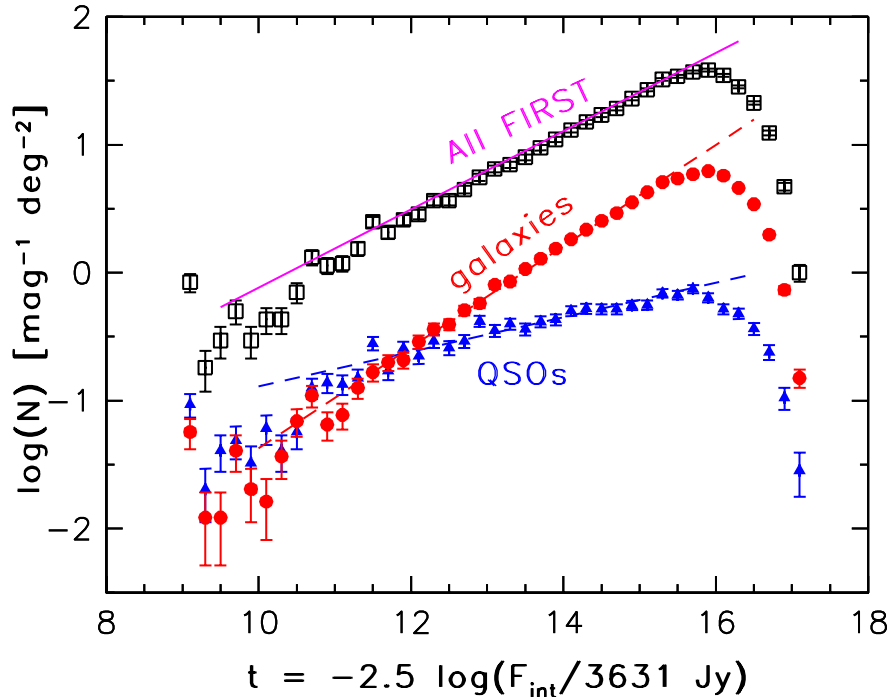

FIRST sources with SDSS detections

- About 20% of SDSS-FIRST sources (with $r < 21$) are optically unresolved
- The fraction of optically unresolved SDSS-FIRST sources decreases with radio flux
- SDSS quasars with FIRST detections are slightly (~ 0.1 mag) redder than other quasars

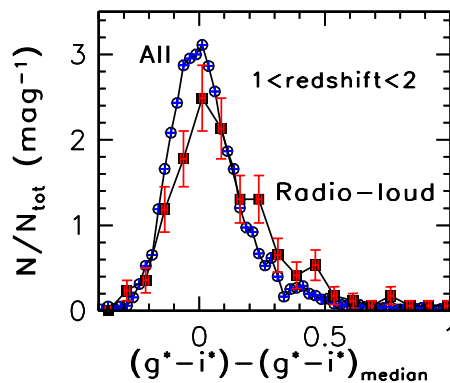
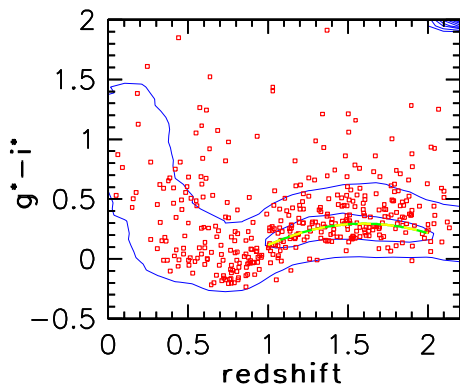

Outline

1. Introduction to Quasars and AGNs
2. Multi-wavelength Observations
3. The Unified AGN Model

How do We Find Quasars and AGNs?

SDSS has (just) produced the largest samples ever obtained.

The Sloan Digital Sky Survey (SDSS) Quasar Sample



Spectra of $\sim 100,000$ quasars in 10,000 sq. deg.

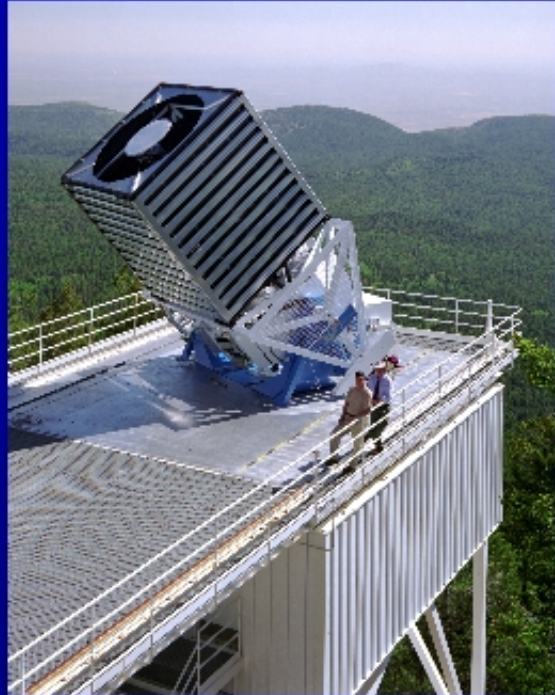

$i < 19.1$ for $z < 3.0$

$i < 20.2$ for $z > 3.0$

Both color and radio selection

See Richards et al. 2002, AJ, 123,
2945 for details

So far: $\sim 50,000$ quasars from $z=0$ to $z=6.4$

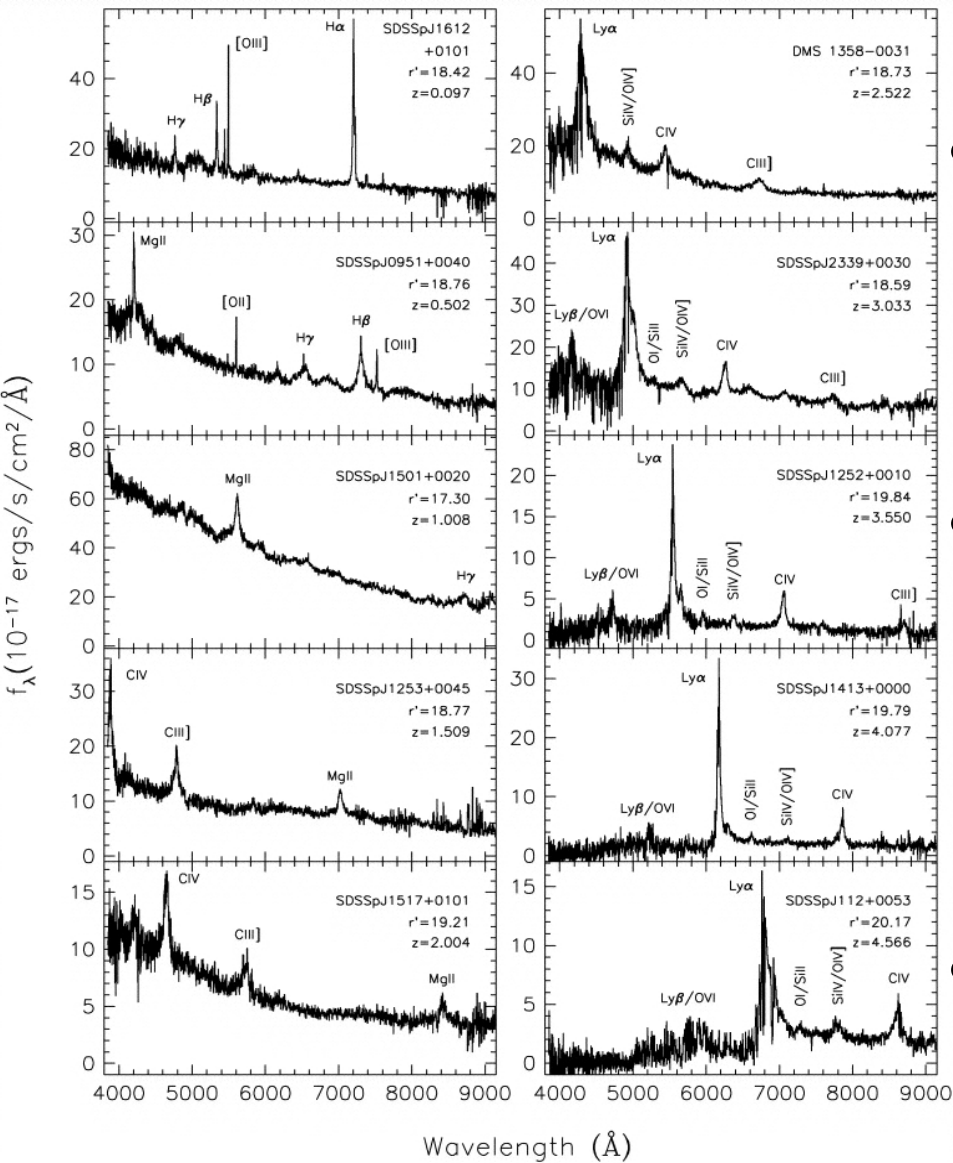

Quasar SEDs

- Quasars are typically at large redshifts (up to ~ 6); **observed** SEDs greatly differ because a given observed wavelength range samples different rest-frame wavelength range
- First QSOs were detected in radio observations, but only $\sim 10\%$ of QSOs are radio loud (the remaining 90% have radio fluxes about 100-1000 weaker, when normalized by optical flux)
- Most modern quasar surveys select candidates using optical colors

Quasar Color Selection

- Quasar SED may produce similar SDSS colors as blue stars.

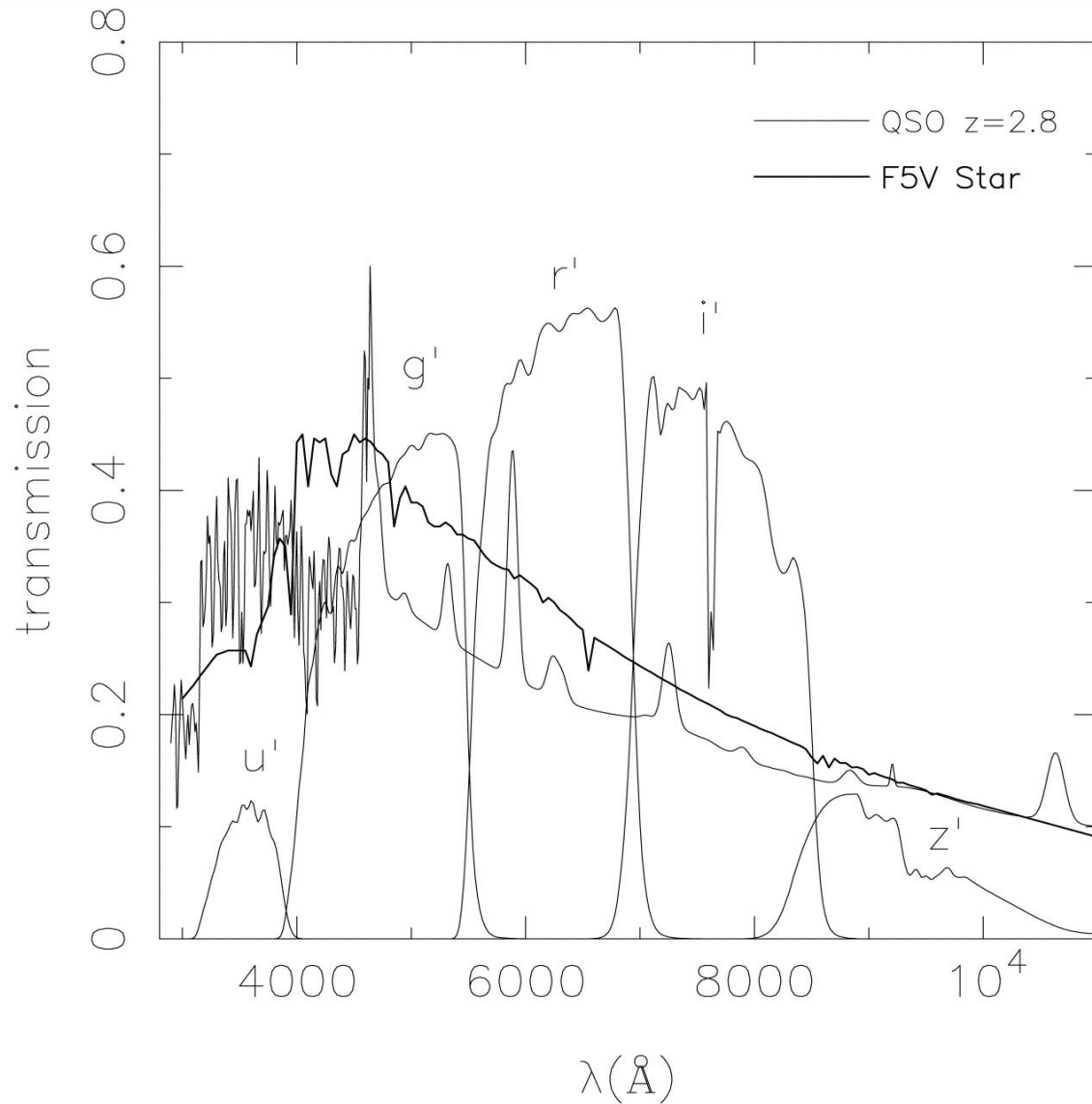

Quasar Color Selection

- K-correction helps to distinguish QSOs from stars

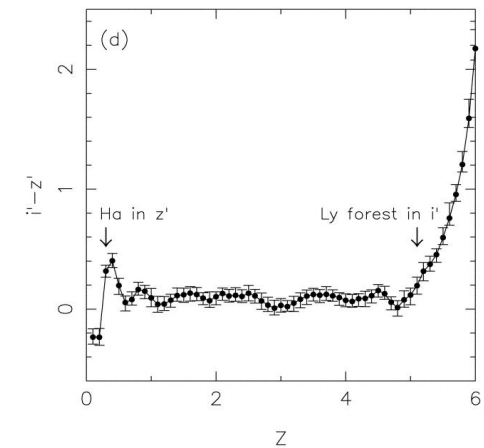
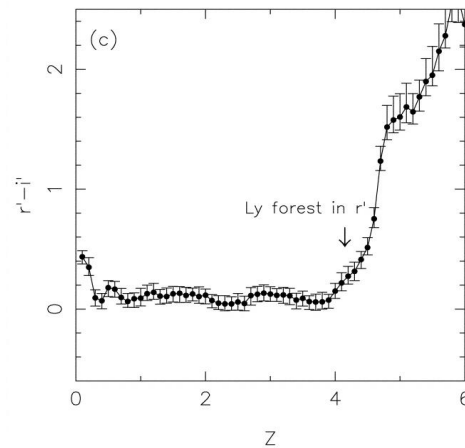
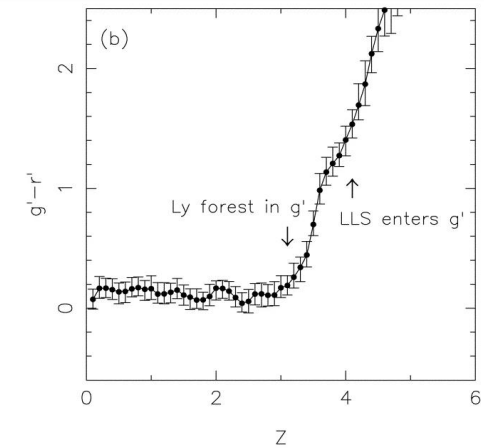
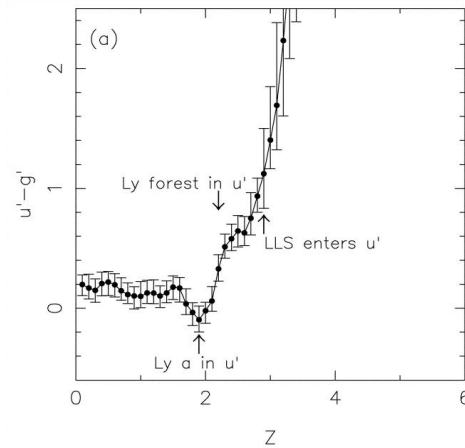
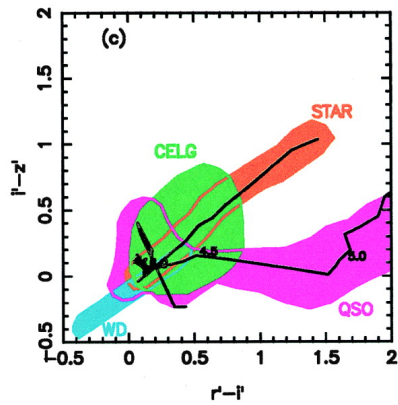
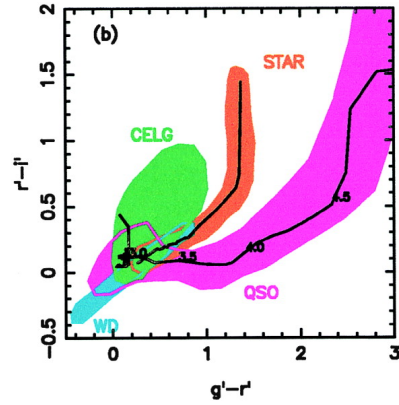
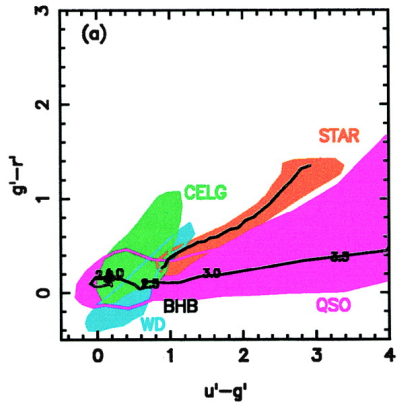

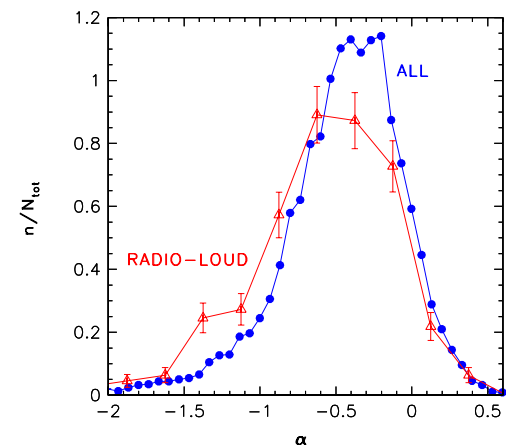
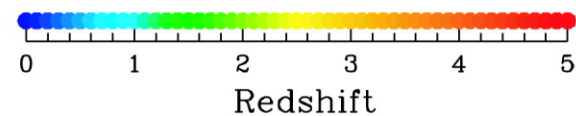
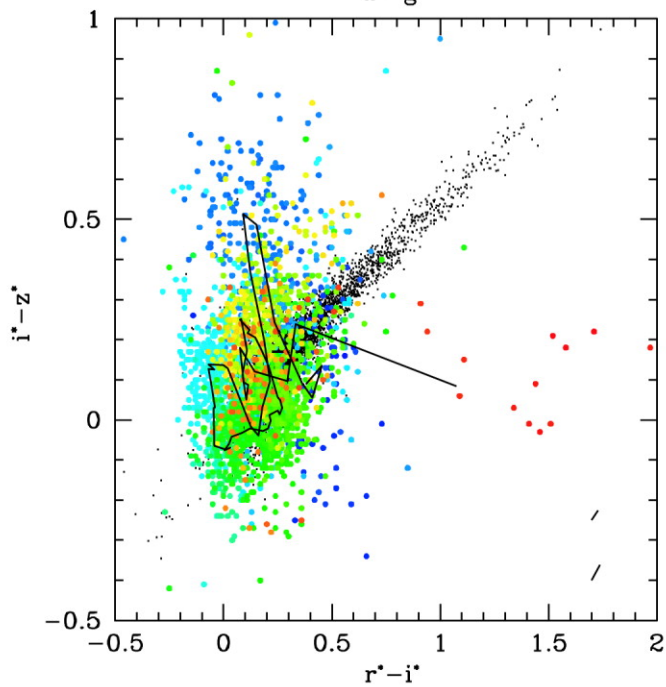
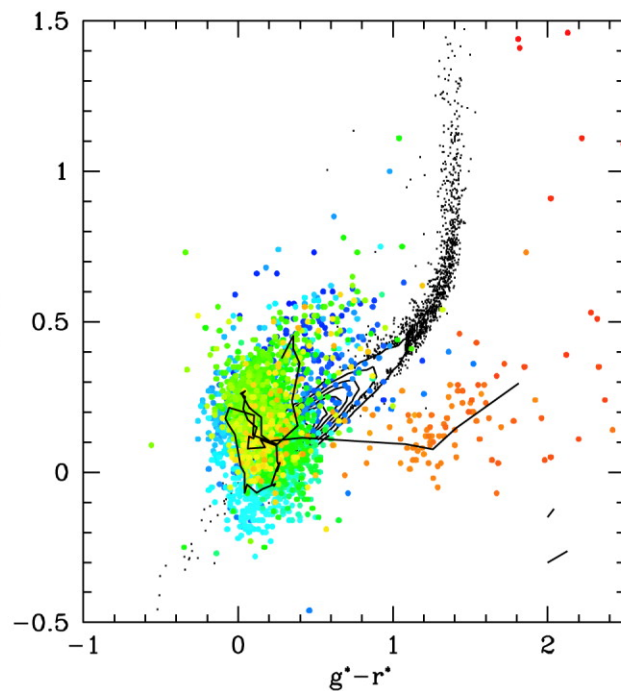
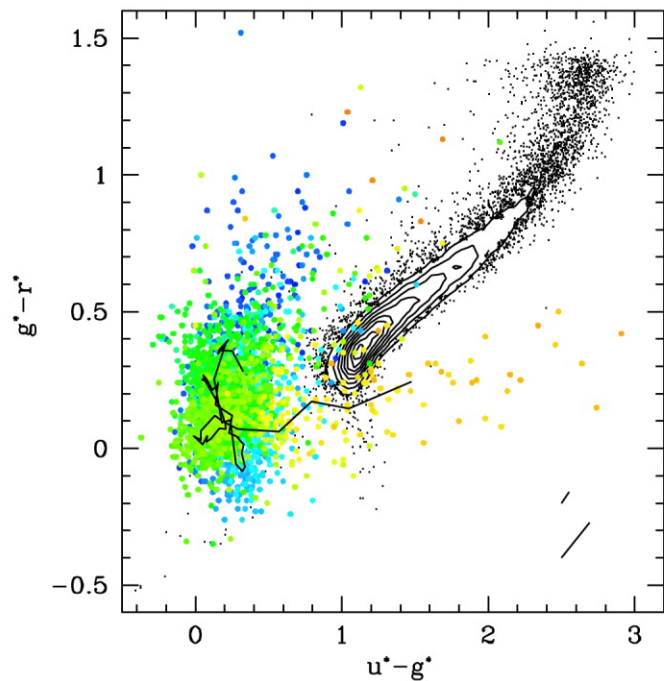

Colors of SDSS quasars

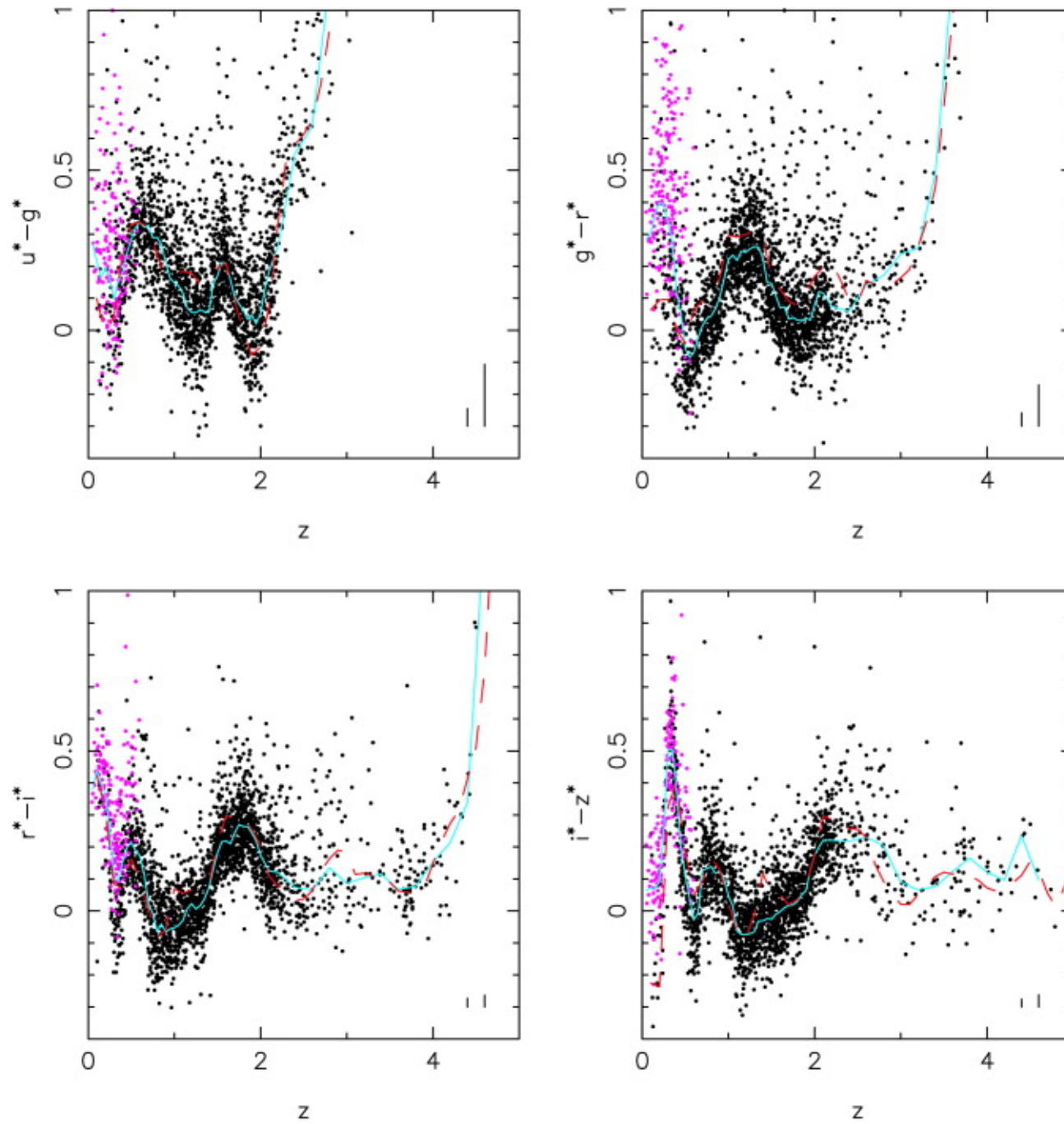

The wiggles are due to emission lines

Quasars and AGNs

1. Introduction to Quasars and AGNs
2. Multi-wavelength Observations
3. The Unified AGN Model
 - Observational Motivation
 - The Basic Predictions and Problems
 - Possible Solutions

The Unified AGN Model

- There is a whole zoo of different quasar/AGN types that differ in various observational properties
- The morphology of radio jets tells us that these are **not spherically symmetric objects** – the viewing angle must be important
- Types 1 and 2 (or I and II) differ a lot!
- The Unified AGN Model explains the difference between types 1 and 2 as due to **different viewing angle** towards fundamentally same type of source/physical system

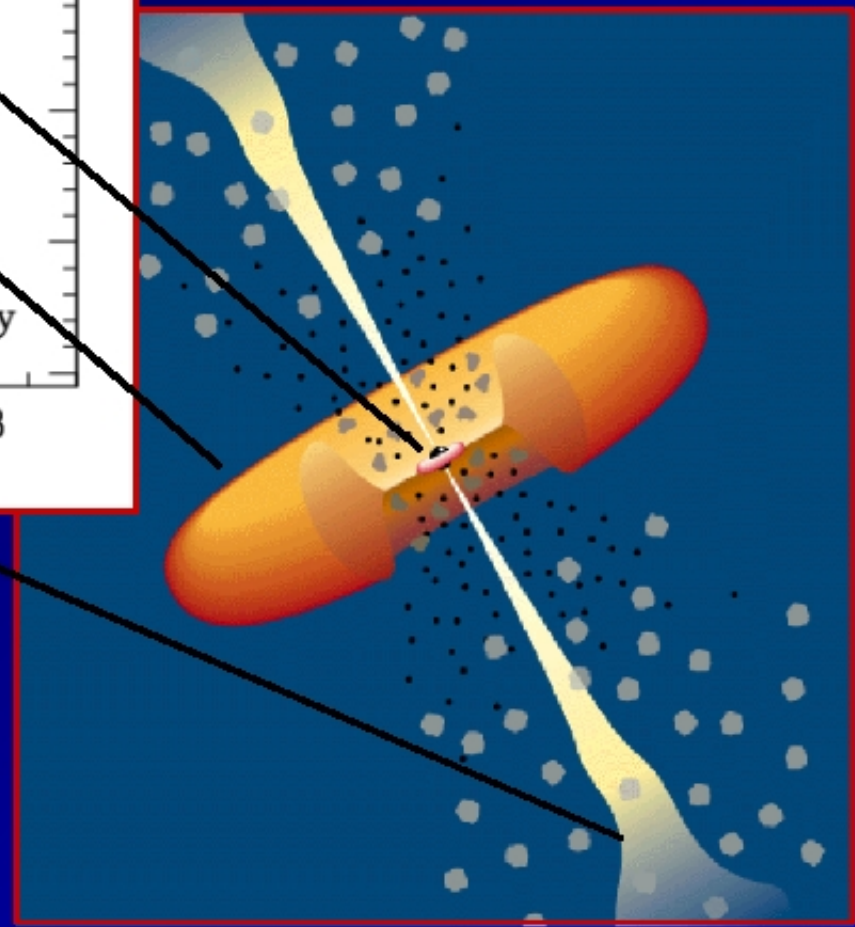
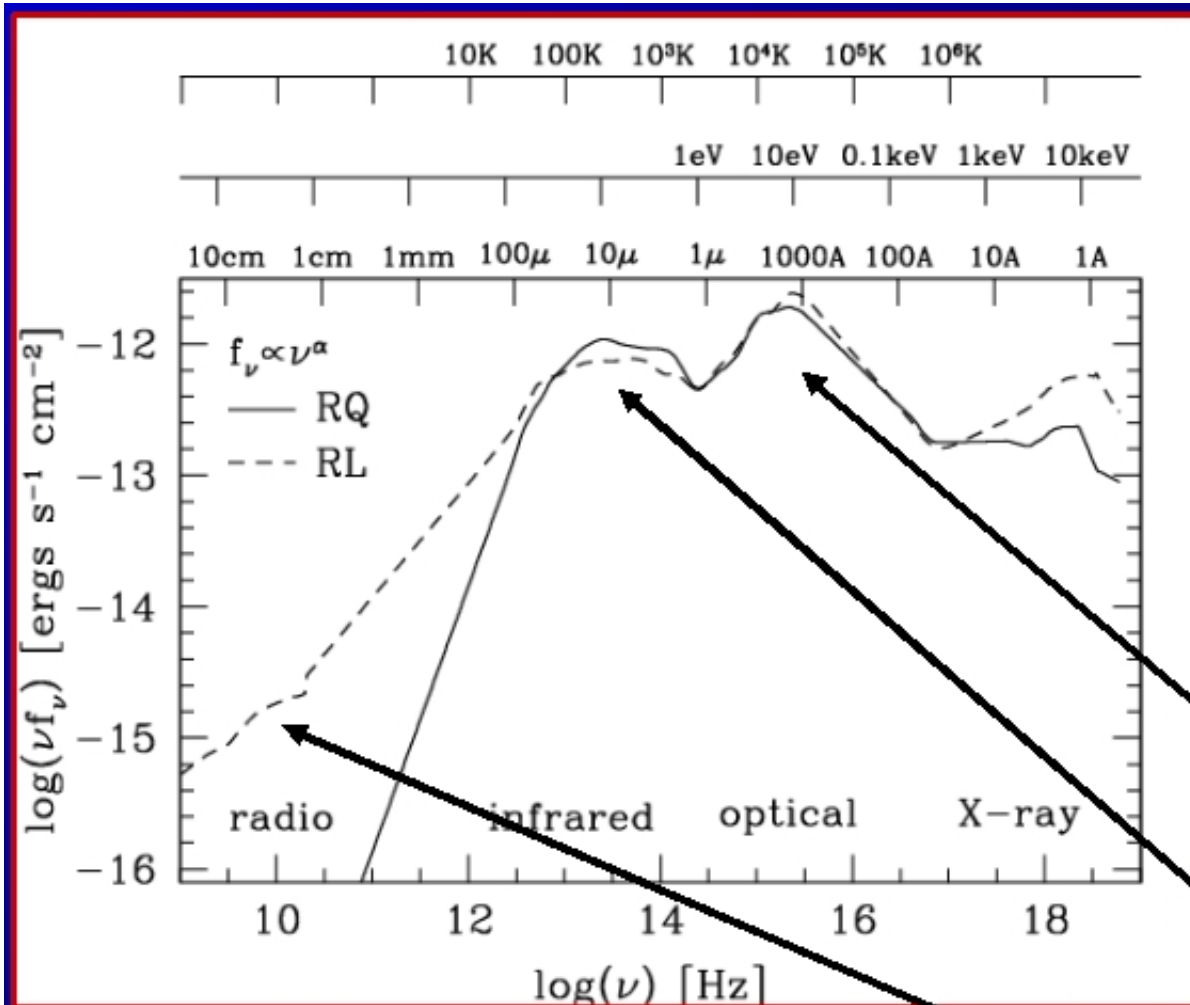

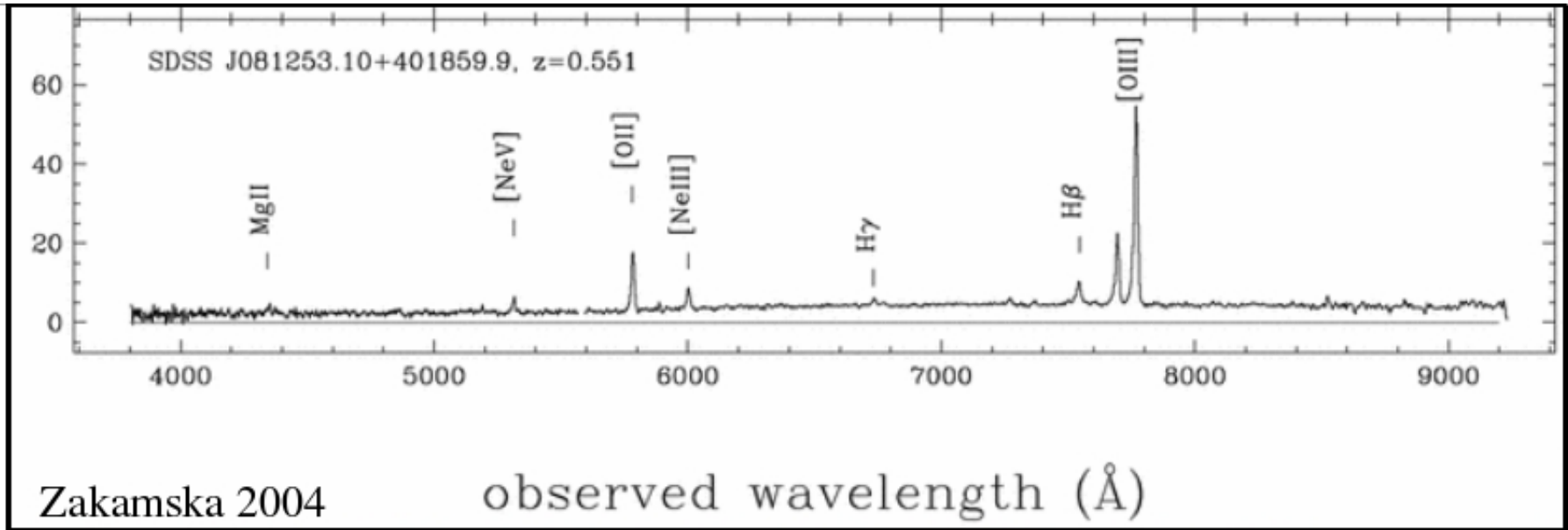

Zakamska 2004

US

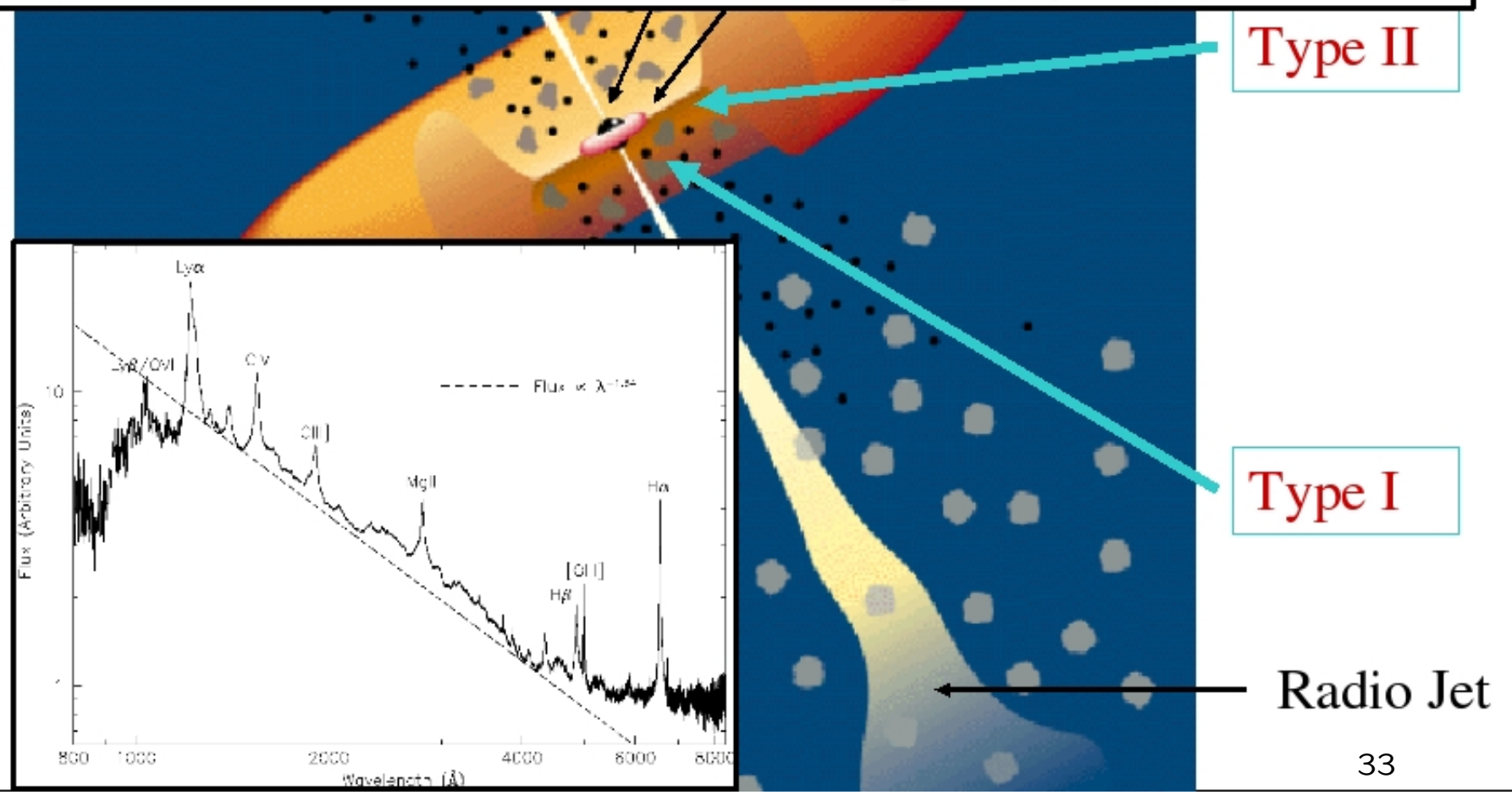

The Unified Model

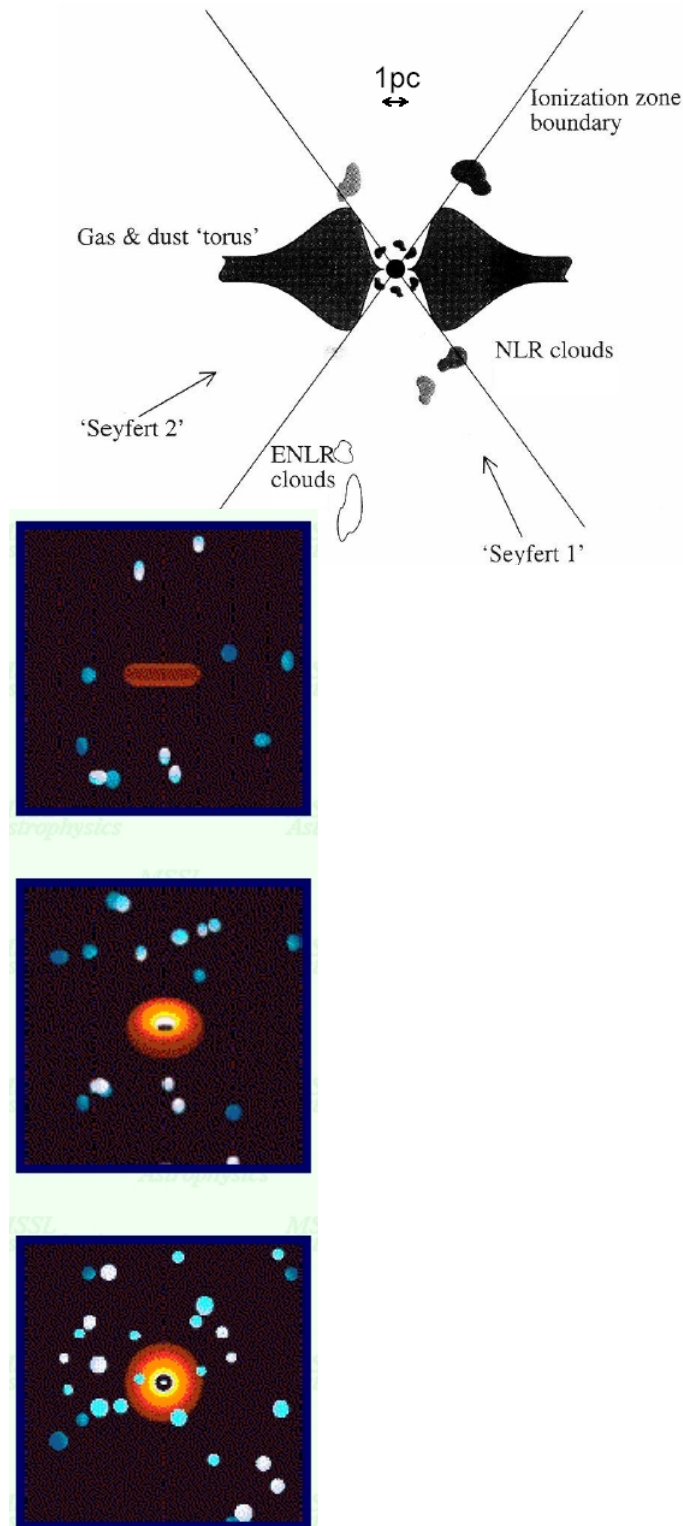

- The Unified Model states that apparently different objects, such as type 1/2 quasars and AGNs, radio galaxies, blazars, etc. are the same (complex) phenomenon seen at different viewing angles.
- If seen **pole on**, we can see all the components
- If seen **edge on**, the dusty torus completely obscures the UV and optical light from the accretion disk, the broad line region, and to some extent X-rays (more soft than hard X-rays)
- In optical, if **pole on** object, and not very luminous, we see the host galaxy, with narrow and broad emission lines indicating an AGN, and we call it Seyfert 1

The Unified Model

- In optical, if **pole on** object, and not very luminous, we see the host galaxy, with narrow and broad emission lines indicating an AGN, and we call it Seyfert 1
- In optical, if **pole on** object, and very luminous, it outshines the host galaxy, we see a quasar; sometimes ($\sim 10\%$) it also has radio emission
- In optical, if **edge on** object, we see the host galaxy, with only the narrow lines emission lines, and we call it Seyfert 2.
- Until recently, type II quasars, the high-luminosity analogs of Seyfert 2 galaxies, were not known. However, over the last decade several hundred objects were found (mostly by SDSS)

- Sometimes a galaxy doesn't show optical evidence for an AGN, but it has strong radio emission (often lobes indicating jets) – it is believed that this radio emission is coming from an AGN that is so strongly obscured in the optical that all the evidence is lost.
- Blazars are AGNs viewed along a line of sight close to that of the radio axis. They are usually optical variables.
- Some quasars/AGNs have a lot of radio emission (radio-loud) and some don't. Why this should be is not clear. The creation of jets which lead to the extended lobe emission is poorly understood. Strong magnetic fields are needed to create the amount of collimation seen at the highest resolutions. These are *believed* to be related to the rate of spin of the central blackhole, which are sped up by mergers.

Small print: although it is possible to find many objects that do not fit in to [the Unified Model](#), we at least have [a framework in which one can begin to understand AGN](#)

Line Spectra

Type 2: Narrow Lines

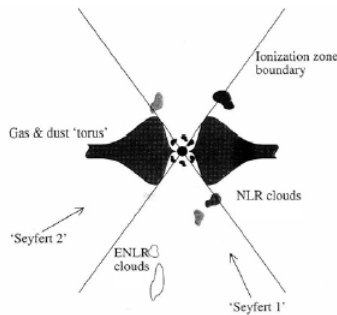

Type 1: Broad Lines

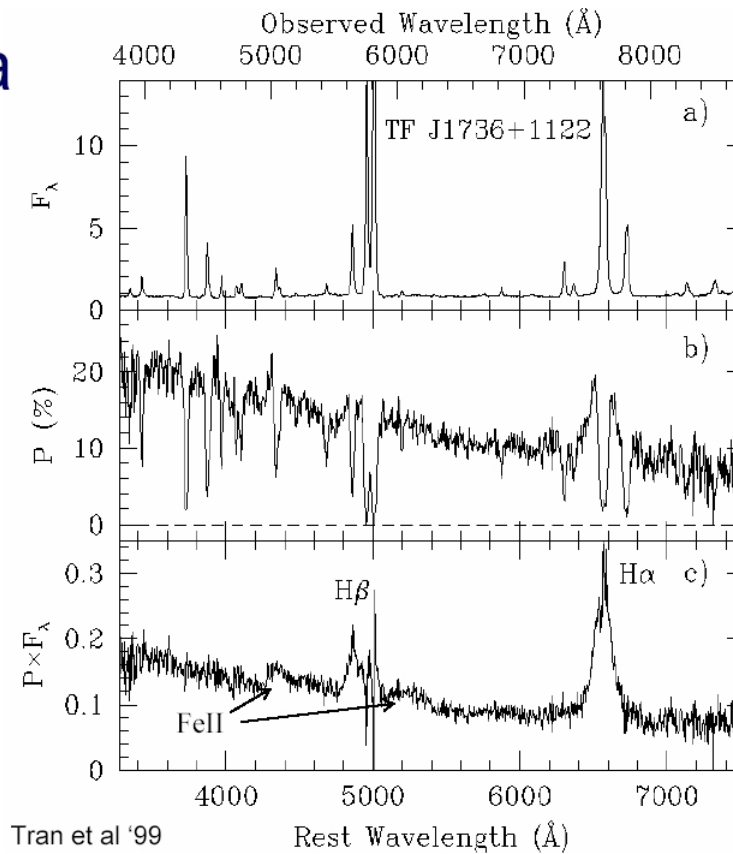

Tran et al '99

Polarization Measurements

- Strong evidence in favor of the Unified Model
- Polarized light implies scattering; it can be used to extract the scattered component which is tiny compared to the direct light: we can peek behind (or around?) the dusty torus!

- The scattered light (the total light times the polarization fraction) reveals broad lines! Explanation: **the broad-line region is hidden behind the torus, but some of its light is scattered towards us** (perhaps from narrow-line clouds, or perhaps diffuse medium)

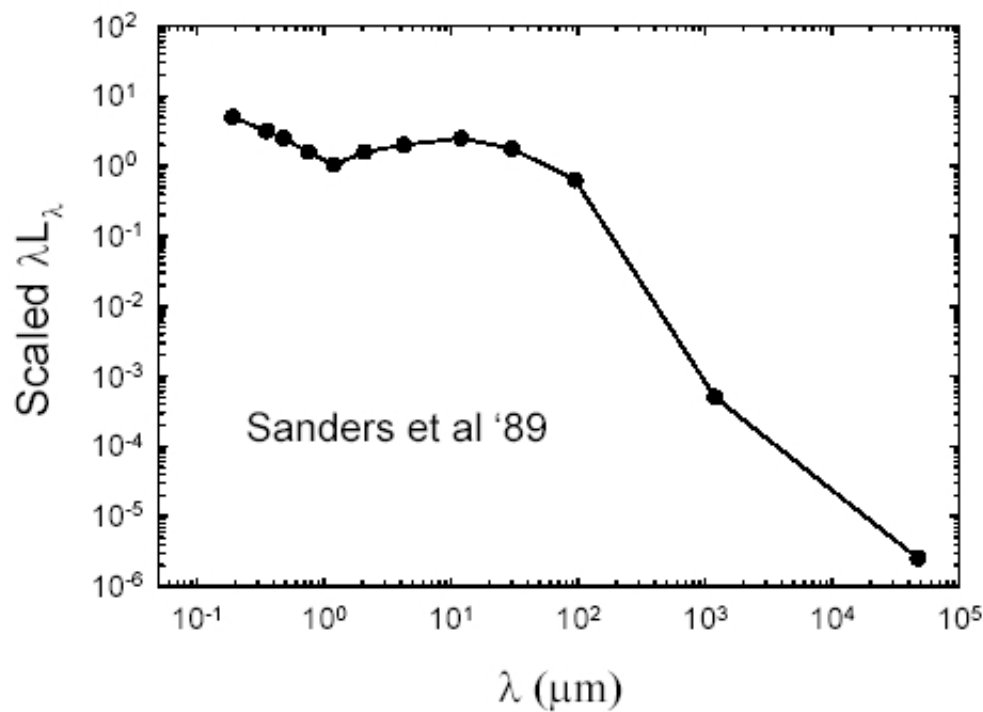

Type 1- Composite

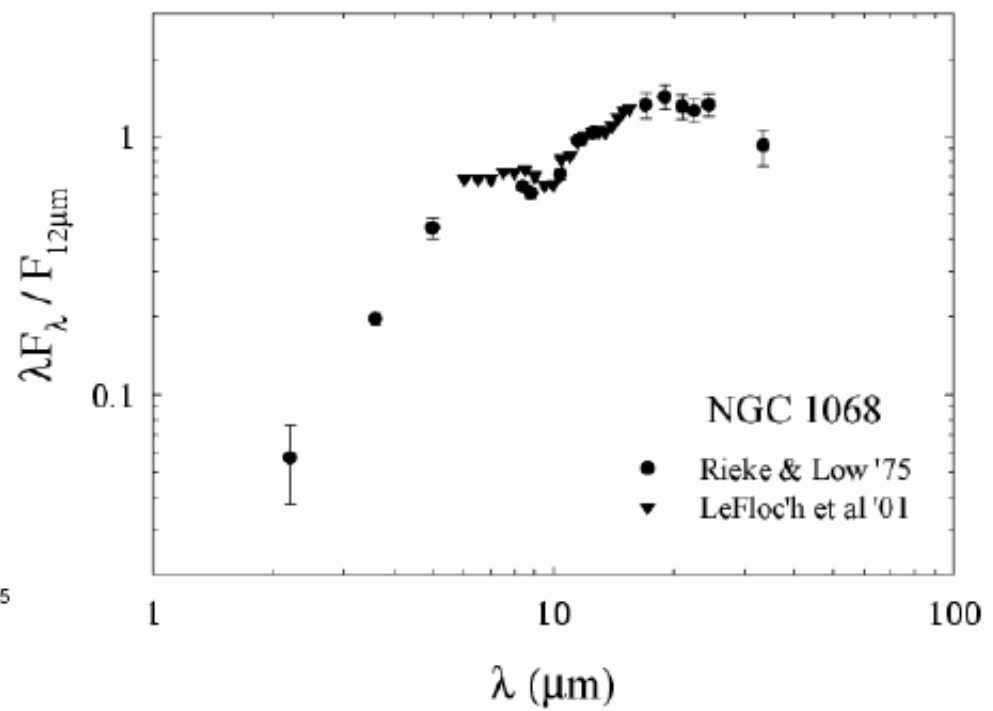

Type 2

Optical type I vs II distinction is well correlated with IR SEDs: flux from type II increases with wavelength and shows a silicate absorption feature at $10\mu\text{m}$

Pier & Krolik 92, 93:

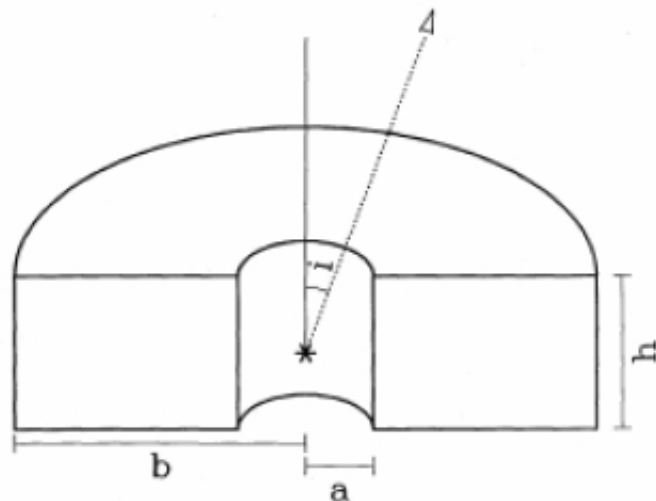
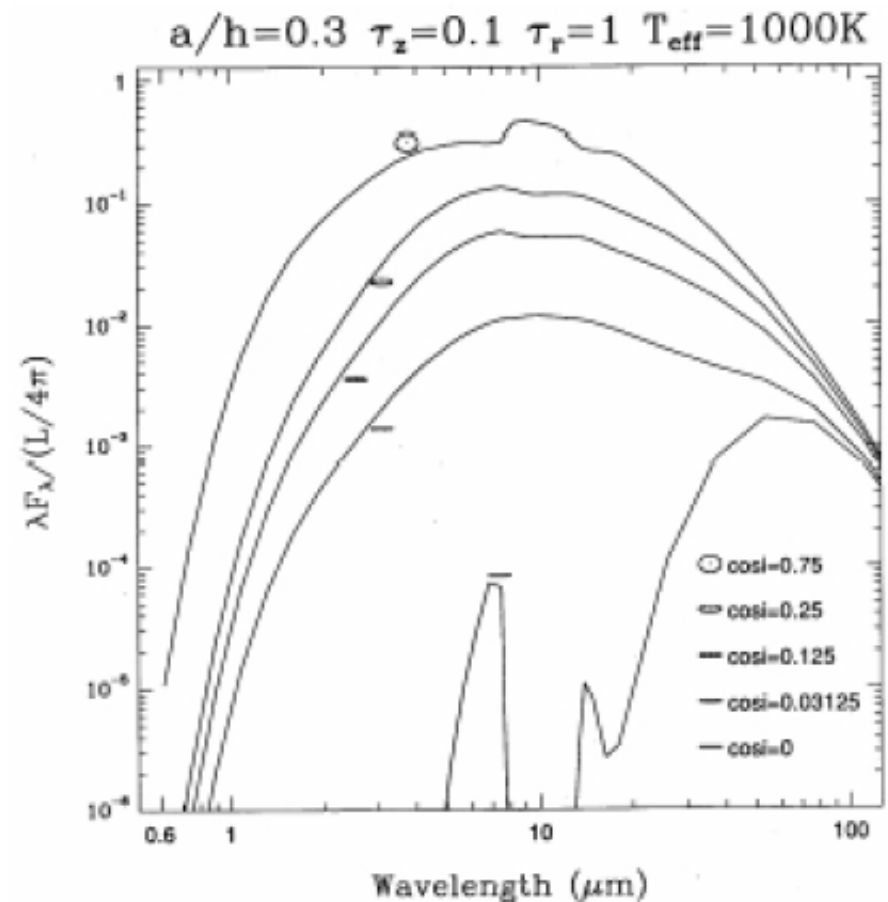

FIG. 1.—Our model dust torus, with inner radius, a , outer radius, b , and height, h viewed from angle i , measured as shown. The central nucleus is indicated by an asterisk. We have assumed constant density throughout the torus.

- Uniform density (even though clumpy)
- No scattering



$$\lambda = 10 \mu\text{m} \Leftrightarrow T \text{ ⌚ } 300\text{K}$$

- IR peak not broad enough
- $10 \mu\text{m}$ problem—fine tuning

Clumpy torus

- Motivation: **unsolved problems with smooth dusty torus**

- 10 μm feature is never very deep, and rarely seen in emission

- the model SEDs are too narrow



(Type 2)

- a great range of dust optical depth (inferred from X-ray observations), but IR SEDs are fairly similar

- **A solution** is to assume dust distributed in clumps (or clouds), Nenkova, Ivezić & Elitzur (2002)

- **Why does clumpy dust help?**

 (Type 1)

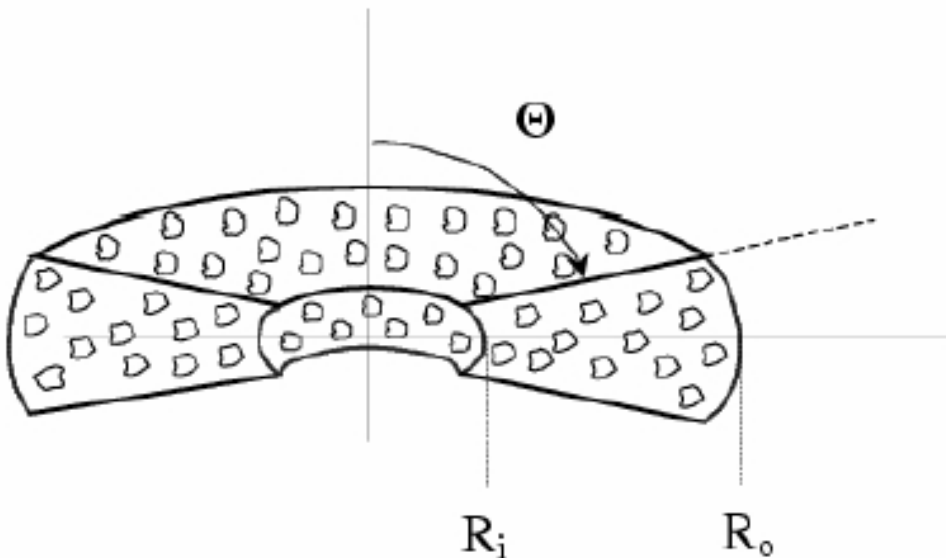

s1



s2



We can see both hot and cold side of clumps

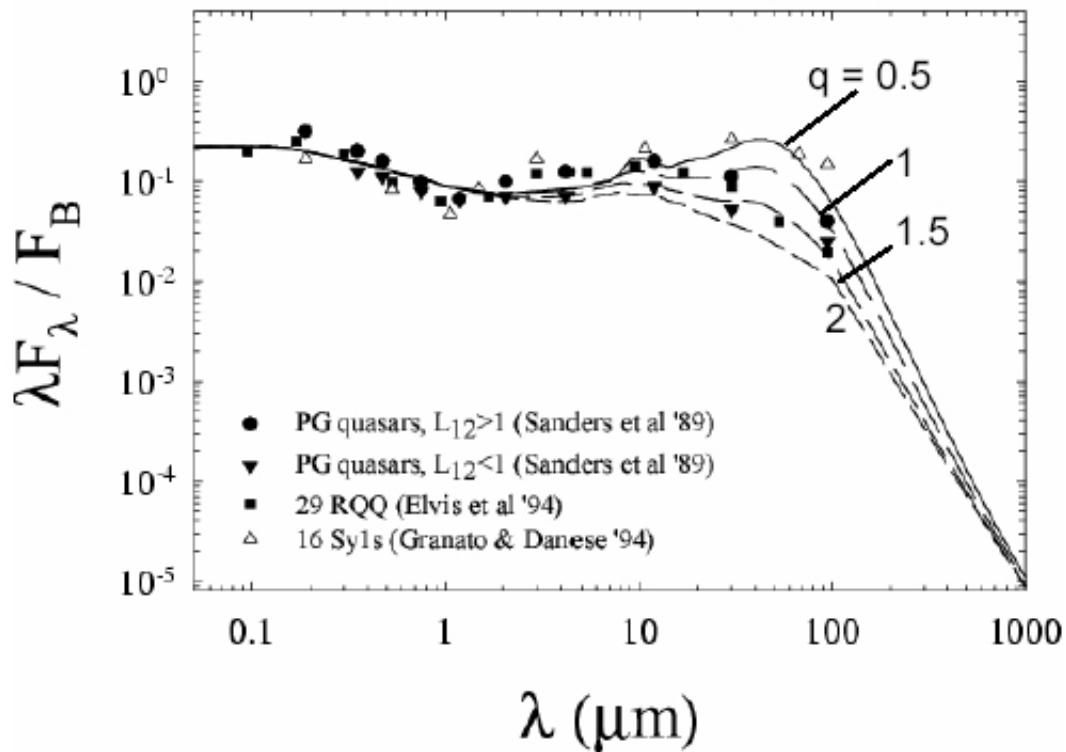

data: type 1 (composites)

models: face-on

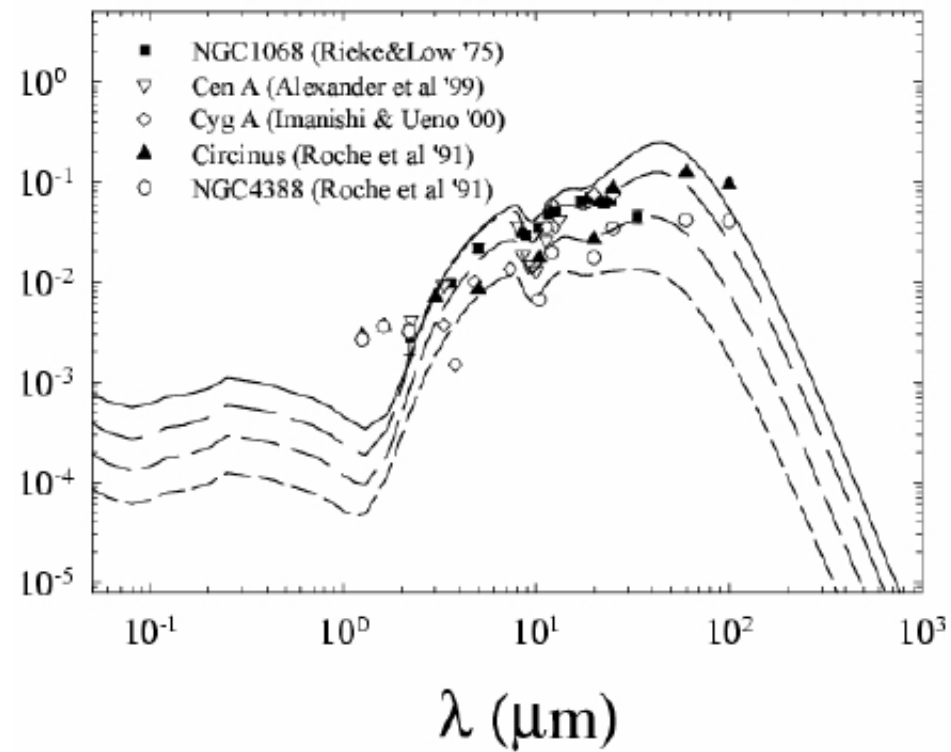

data: type 2 (individual)

models: edge-on

Nenkova et al. models vs. data comparison: much improved

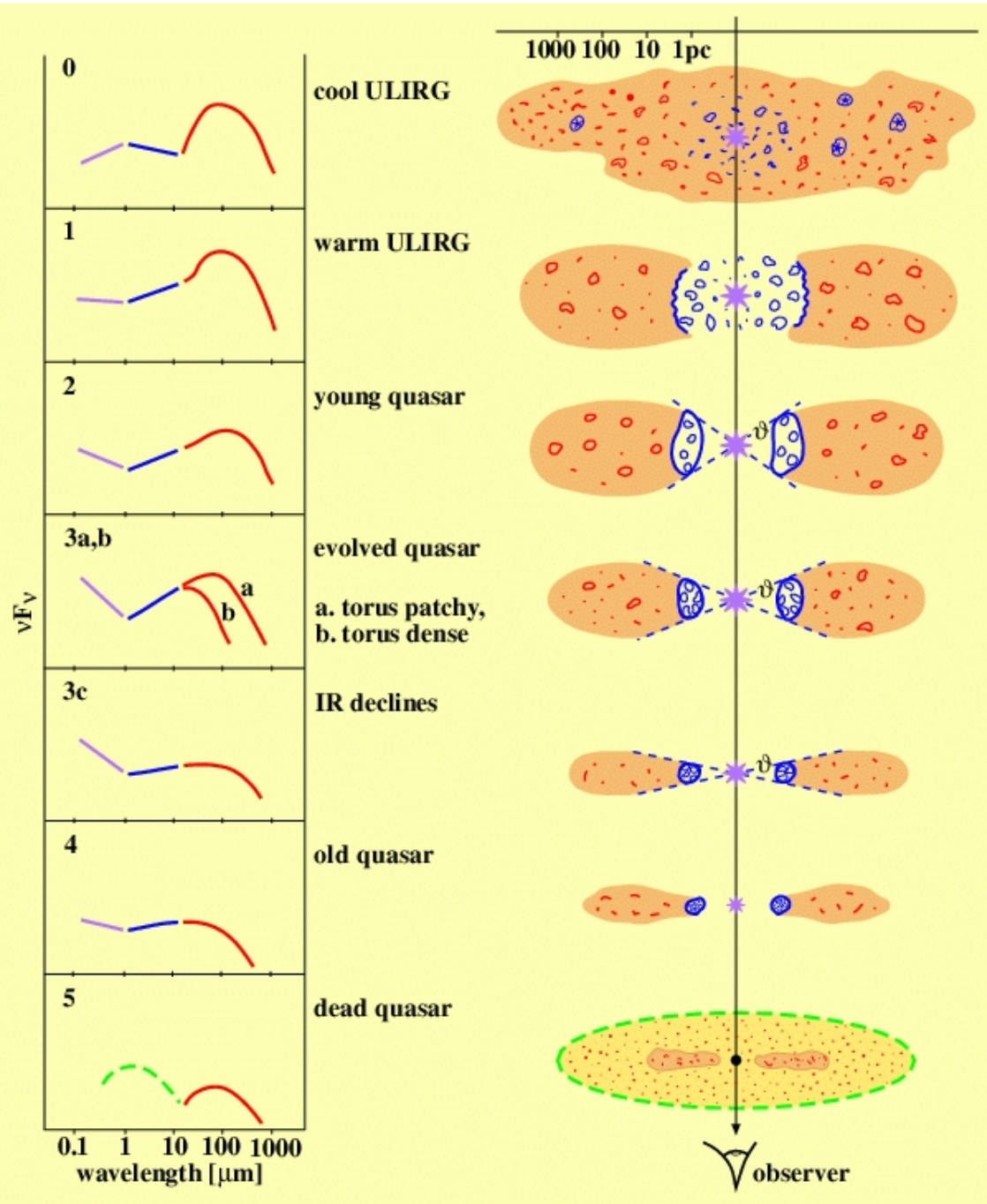

Torus evolution

- From Haas et al. (2003): constructed good SEDs for a large number of quasars; explained the SED diversity as an evolutionary sequence
- Evolution goes from top to bottom: the dust distribution rearranges, settling more into a torus/disk like configuration
- The SEDs show initially far-IR bump, then an increase in mid-IR emission, and then an overall decline in IR emission
- A neat addition to the Unified Model that nicely explains some data features