

Title no. 99-S55

Shear Strength of Steel Fiber-Reinforced Concrete Beams without Stirrups

by Yoon-Keun Kwak, Marc O. Eberhard, Woo-Suk Kim, and Jubum Kim

Twelve tests were conducted on reinforced concrete beams with three steel fiber-volume fractions (0, 0.5, and 0.75%), three shear span-depth ratios (2, 3, and 4), and two concrete compressive strengths (31 and 65 MPa). The results demonstrated that the nominal stress at shear cracking and the ultimate shear strength increased with increasing fiber volume, decreasing shear span-depth ratio, and increasing concrete compressive strength. As the fiber content increased, the failure mode changed from shear to flexure.

The results of 139 tests of fiber-reinforced concrete beams without stirrups were used to evaluate existing and proposed empirical equations for estimating shear strength. The test population included beams with a wide range of beam properties, but most of the beams were small. The evaluation indicated that the equations developed by Narayanan and Darwish and the equations proposed herein provided the most accurate estimates of shear strength and the onset of shear cracking. For the proposed procedure, the ratio of the measured strength to the calculated strength had a mean of 1.00 and a coefficient of variation of 15%.

Keywords: beam; cracking; shear strength.

INTRODUCTION

The addition of steel fibers to a reinforced concrete beam is known to increase its shear strength and, if sufficient fibers are added, a brittle shear failure can be suppressed in favor of more ductile behavior.^{1,2} The increased shear strength and ductility of fiber-reinforced beams stems from the post-cracking tensile strength of fiber-reinforced concrete. This residual strength also tends to reduce crack sizes and spacings. The use of steel fibers is particularly attractive for high-strength concrete, which can be relatively brittle without fibers, or if conventional stirrups can be eliminated, which reduces reinforcement congestion.

The literature describes numerous studies of rectangular, fiber-reinforced beams without stirrups,²⁻²¹ of which 16³⁻¹⁸ were reviewed by Adebar et al.² Batson, Jenkins, and Spatney performed the first large experimental study of such beams,⁴ which included 42 tests of fiber-reinforced beams without stirrups that failed in shear. Subsequent investigations of normal-strength concrete^{6,7,9-17} (primarily in the 1980s) and high-strength concrete^{3,5,19,21} (primarily in the 1990s) confirmed the effectiveness of adding steel fibers and identified key parameters that affect shear strength. The increase in shear strength can vary drastically depending on the beam geometry and material properties. For example, in tests reported by Narayanan and Darwish,¹³ the increase in shear strength attributable to steel fibers varied from 13 to 170%.

As with conventional reinforced concrete beams,²²⁻²⁴ the ultimate shear strength decreases with increasing shear span-depth ratio a/d ;^{3,4,5,9-13,21} increases with increasing flexural reinforcement ratio ρ ;^{3,5,13} and increases with increasing concrete compressive strength f'_c .^{13,21} These effects are attributable to the development of arch and dowel action in

beams with low values of a/d , and to the diagonal-tension failure mode (beam action) in beams with higher values of a/d . Li, Ward, and Hamza⁹ also report that, as has been observed in conventional beams, the average shear stress at failure decreases with increasing beam depth.

The increase in shear strength attributable to the fibers depends not only on the amount of fibers, usually expressed as the fiber volume fraction V_f , but also on the aspect ratio^{6,7,9,12,13} and anchorage conditions for the steel fibers.^{9,13,21} For example, from the point of view of workability, it may be convenient to use stocky and smooth fibers, but after the concrete cracks, such fibers will resist tension less well than elongated fibers with end deformations (hooked or crimped).

Investigators have also developed empirical expressions for calculating shear strength. For example, Sharma;¹⁶ Narayanan and Darwish;¹³ Ashour, Hasanain, and Wafa;³ and Imam et al.²⁵ have proposed equations for predicting the ultimate average shear stress v_u . Although the onset of shear cracking is difficult to establish reliably, Narayanan and Darwish¹³ also proposed a procedure for estimating the average shear stress at the onset of shear cracking v_{cr} .

Despite this research activity, the existing design expressions have not been evaluated with a large amount of test results and, in some cases, the data used to calibrate models of shear strength included tests of beams that failed in flexure rather than in shear. Proposed and existing design procedures for estimating shear strength need to be evaluated using a large collection of test results for beams that failed in shear.

RESEARCH SIGNIFICANCE

Previous studies have documented many tests of fiber-reinforced concrete beams without stirrups that failed in shear. The results of new tests, combined with the results of previous tests, provide the opportunity to evaluate the accuracy of existing and proposed design procedures. Such an evaluation is needed before building codes²² will recognize the contribution of steel fibers to the shear strength of reinforced concrete beams.

TEST PROGRAM

Twelve reinforced concrete beams were tested to failure to evaluate the influence of fiber-volume fraction a/d and concrete compressive strength on beam strength and ductility (Table 1). The first 9 beams, denoted by the letters FHB (fiber-reinforced, higher-strength concrete beams) were constructed

ACI Structural Journal, V. 99, No. 4, July-August 2002.

MS No. 01-402 received November 27, 2001, and reviewed under Institute publication policies. Copyright © 2002, American Concrete Institute. All rights reserved, including the making of copies unless permission is obtained from the copyright proprietors. Pertinent discussion will be published in the May-June 2003 *ACI Structural Journal* if received by January 1, 2003.

Yoon-Keun Kwak is a professor of architectural engineering at Kum-Oh National University of Technology, Gumi, Korea.

Marc O. Eberhard is an associate professor of civil and environmental engineering at the University of Washington, Seattle, Wash. He is a member of Joint ACI-ASCE Committee 445, Shear and Torsion.

Woo-Suk Kim is a graduate research assistant in the department of architectural engineering at Kum-Oh National University of Technology.

Jubum Kim is a graduate research assistant in the department of civil and environmental engineering at the University of Washington.

with concrete having a compressive strength near 65 MPa. These higher-strength beams included all combinations of three steel-fiber volume fractions ($V_f = 0, 0.5, \text{ and } 0.75\%$) and three a/d s ($a/d = 2, 3, \text{ and } 4$). The last three beams (Test Series FNB2), which had an average compressive strength of 31 MPa, were included to evaluate the effect of concrete compressive strength on shear strength. For these three beams, the steel fiber-volume fraction was kept constant at 0.5%, while a/d varied from 2 to 4.

Figure 1 shows the details of the test beams. All of the beams had nominally identical cross-sectional dimensions (125 x 250 mm), effective depths (212 mm), and flexural reinforcement (two D16 bars). These dimensions correspond to a flexural reinforcement ratio of 1.5%. The longitudinal bars were hooked upwards behind the supports and enclosed by three D10 stirrups at each end. This detail precluded the possibility of anchorage failure, which can be important in practice. No stirrups were included within the shear span.

To prevent the beam from developing significant axial forces, which could create artificial strut action, the beams were supported by a roller on one end and a hinge at the other as shown in Fig. 1. At both of these locations, the contact area between the concrete and the supports measured 125 mm (the width of the beam) x 150 mm. Two equal loads were applied to

the beam using a steel spreader beam and 80 mm-wide x 40 mm-thick loading plates. At the beginning of each test, deflections were imposed by increasing the load in small increments but, as the beam approached its capacity, the test was controlled by gradually increasing the beam deflection. The applied load and the beam deflection at midspan were recorded continuously until failure.

Material properties

Table 2 provides the mixture designs and slumps for the four mixtures. The water-cement ratio (w/c) was 0.33 for the

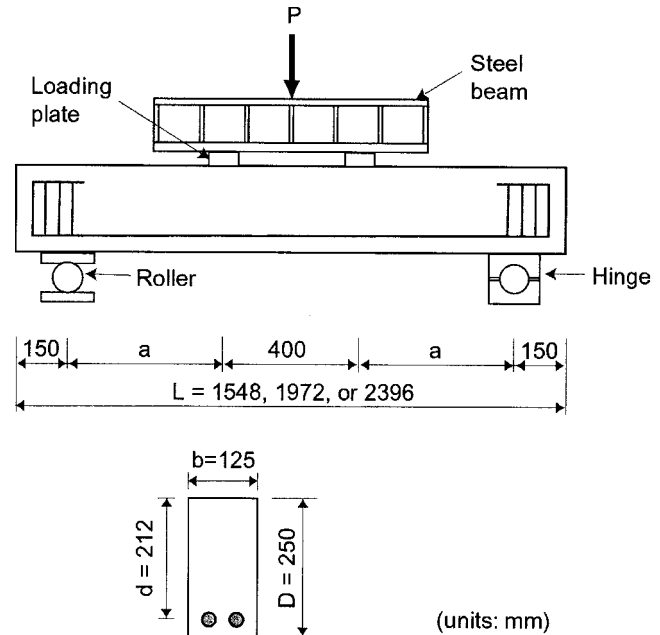

Fig. 1—Details of test beams.

Table 1—Summary of test program

Beam designation	Fiber-volume fraction V_f , %	Shear-span/depth ratio a/d	Concrete compressive strength f'_c , MPa	Average shear stress		Ultimate displacement, mm	Failure mode
				v_{cr} , MPa	v_u , MPa		
FHB1-2	0	2.0	62.6	1.67	3.02	6.08	Shear
FHB2-2	0.5	2.0	63.8	1.94	5.09	16.50	Shear-flexure
FHB3-2	0.75	2.0	68.6	2.22	5.44	34.35	Shear-flexure
FHB1-3	0	3.0	62.6	1.48	2.53	9.68	Shear
FHB2-3	0.5	3.0	63.8	1.67	3.09	18.2	Flexure
FHB3-3	0.75	3.0	68.6	1.80	3.40	33.59	Flexure
FHB1-4	0	4.0	62.6	1.26	1.98	13.86	Shear
FHB2-4	0.5	4.0	63.8	1.54	2.41	28.49	Flexure
FHB3-4	0.75	4.0	68.6	1.57	2.74	43.87	Flexure
FNB2-2	0.5	2.0	30.8	1.30	4.04	8.93	Shear
FNB2-3	0.5	3.0	30.8	1.11	2.55	10.81	Shear
FNB2-4	0.5	4.0	30.8	1.07	2.0	41.07	Flexure

Table 2—Concrete mixture designs

Type	V_f , %	Quantity of material				w/c , %	Slump, mm
		Cement, kg/m^3	Fine aggregate, kg/m^3	Coarse aggregate, kg/m^3	High-range water-reducing admixture, l		
FHB1 Series	0	480	560	1060	9.35	33	104
FHB2 Series	0.5	480	560	1060	10.5	33	96
FHB3 Series	0.75	480	560	1060	12.4	33	83
FNB2 Series	0.5	299	704	1098	—	62	131

higher-strength beams (FHB1, FHB2, and FHB3) and 0.62 for the normal-strength beams (FNB2). The concrete was made with Type I portland cement. The coarse aggregates were crushed gravel with a maximum size of 19 mm, and the fine aggregates were natural river sand with a fineness modulus of 2.17. A high-range water-reducing admixture was used to improve the workability of the higher-strength concrete.

The steel fibers were hooked, 50 mm long, and 0.8 mm in diameter, which corresponds to an aspect ratio of 62.5. The nominal yield strength of the steel fibers was 1079 MPa. The flexural steel had a yield stress of 442 MPa and an ultimate strength of 638 MPa.

The measured values of compressive strength f'_c , splitting tensile strength f_{sp} , modulus of rupture f_r , and modulus of elasticity E_c for the four mixtures are presented in Table 3. Compressive and splitting tensile strengths were measured with 100 x 200 mm cylinders. The modulus of rupture was evaluated for 150 x 150 x 530 mm concrete beams. As shown in Table 3, the addition of fibers increased the

Table 3—Measured properties of hardened concrete

Type	V_f , %	f'_c , MPa	f_{sp} , MPa	f_r , MPa	E_c , GPa
FHB1 Series	0	62.6	4.32	8.92	33.5
FHB2 Series	0.5	63.8	5.88	10.10	37.8
FHB3 Series	0.75	68.6	6.08	10.69	38.2
FNB2 Series	0.5	30.8	3.83	7.75	31.2

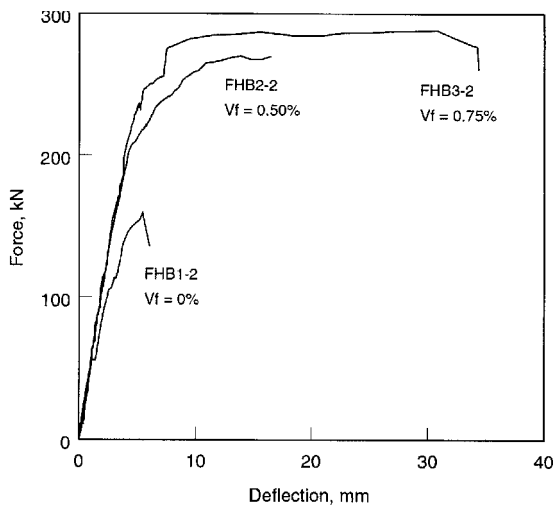

Fig. 2—Typical force-deflection histories ($a/d = 2$).

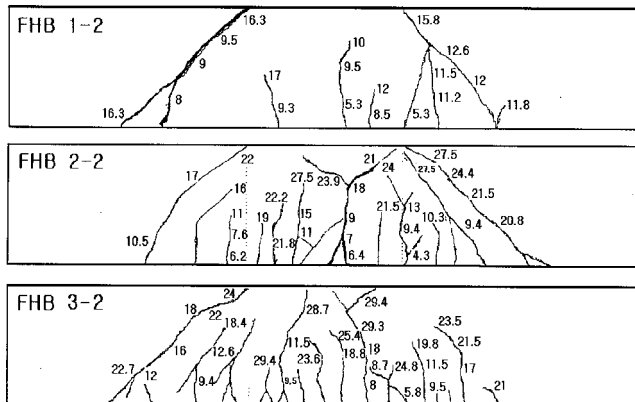

Fig. 3—Typical crack patterns ($a/d = 2$).

splitting strength and modulus of rupture much more than it increased the compressive strength. For example, the addition of 0.5% of fibers (Series FHB2) increased the splitting strength and modulus of rupture by 36 and 13%, respectively, but increased the compressive strength by only 2%.

TEST RESULTS

Typical force-deflection relationships are shown in Fig. 2 for the three higher-strength concrete beams with an a/d of 2.0. As the fiber content increased, both the maximum applied load and ultimate deflection increased also. This behavior was typical of the other beams.

Failure mode

The presence of steel fibers in the concrete greatly affected the observed cracking patterns, which are shown in Fig. 3 for three beams with $a/d = 2$. In this figure, the three beams are identical except for the addition of steel fibers. The numbers next to the cracks refer to the load (in metric tons) at which the cracks were first observed. In Specimen FHB1-2, which had no steel fibers, flexural cracks first formed within the constant-moment region (near midspan), and later, two shear cracks formed (one near each quarter-span point) within the regions of constant shear. The beam failed suddenly along a single shear crack.

As the steel fiber volume increased to 0.50 and 0.75% for FHB2-2 and FHB3-2, respectively, the failure mode changed to a combination of shear and flexure. In such failures, significant diagonal shear cracks and vertical flexural cracks both formed, and may have interacted to produce the failure. The flexural and shear cracks were spaced more closely as the volume of fibers increased (Fig. 3). For example, in the concrete beams without fibers,

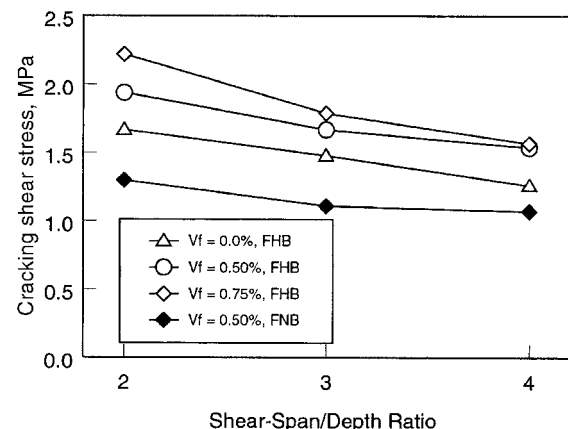
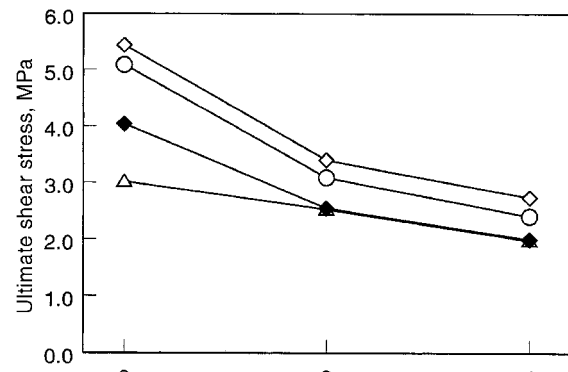

Fig. 4—Influence of a/d on shear resistance.

the crack spacing was typically 90 to 170 mm, whereas this spacing decreased to 70 to 90 mm when fibers were added.

The failure modes for all of the beams are listed in Table 1. All of the concrete beams without fibers failed in shear, which corresponded in each case to sudden failure along a single shear crack. As the fiber content increased, the failure mode changed from shear to shear-flexure ($a/d = 2$) or to flexure ($a/d = 3$ or 4). As shown in Table 1 and Fig. 2, the ultimate deflection increased by up to a factor of 5 (for constant L and a/d) with increasing fiber content. The ultimate deflection was defined as the deflection at which the load resistance dropped significantly.

Ultimate strength

The ultimate shear strengths of the 12 beams are reported in Table 1 in terms of the average shear stress at failure v_u , which is defined as the maximum shear force divided by the beam width and effective depth (that is, $v_u = V/bd$). Figure 4 shows that the average shear stress at failure consistently decreased with increasing a/d . Also, the difference in capacity between beams with $a/d = 2$ and $a/d = 3$ was significantly larger than the difference between beams with $a/d = 3$ and $a/d = 4$. Such behavior was expected because arching action and dowel action become less effective as a/d increases.²³ Similar trends would also be expected for beams failing in flexure. Specifically, if the flexural capacity of the beam M_{ult} controls the maximum shear, then the ultimate shear M_{ult}/a would be proportional to $1/a$.

The effects of fiber content on the strength of fiber concrete beams are illustrated in Fig. 5 for the higher-strength concrete beams. The strength of the fiber-reinforced beams ranged from 122 to 180% of the strength of the beams without fibers. The strength increase was particularly large (69 to 80%) for the beams with low a/d s ($a/d = 2.0$), which failed in a combination of shear and flexure (Table 1). For larger a/d s, which are more typical in practice, the increase in strength ranged from 22 to 38%. These beams failed in flexure, so the applied load at failure is not equal to the shear strength; instead, this load only provides a lower bound on the shear strength.

The effect of concrete strength can be evaluated by comparing six tests of beams with fiber contents of 0.5% (Test Series FHB2 and FNB2). As the concrete strength was approximately doubled (from 31 to 65 MPa), the strength increased (for a given fiber content and shear span) by 21 to 26%.

Onset of shear cracking

The values of average shear stress at shear cracking v_{cr} were computed based on the measured shear at the onset of such cracking (Table 1). As was observed for the ultimate shear, the average shear stress at the onset of shear cracking decreased with increasing a/d (Fig. 4); it increased with increasing fiber content (Fig. 5); and it increased with increasing concrete strength (Table 1). The fibers appeared to be effective in delaying the formation of cracks, or at least in arresting their initial growth.

The effect of steel fibers on cracking shear was smaller than the effect on shear strength. Specifically, the increase in cracking shear ranged from 13 to 33% of the cracking shear of similar beams without fibers (Fig. 5). In contrast, the concrete strength influenced the cracking shear more than the failure strength. Comparing Test Series FHB2 and FNB2, the increase in compressive strength increased the cracking shear by 44 to 50%.

As has been reported for beams without fibers,^{23,24} the beams with small a/d s carried more load after shear cracking than the beams with large a/d s. For example, at an a/d of 2.0, the ultimate shear of the fiber-reinforced beams ranged from 245 to 311% of the cracking shear. In comparison, the ultimate shear ranged from 157 to 230% of the cracking shear for beams with a/d s of 3.0 and 4.0. This difference can be attributed to the instability of the arch mechanism at large a/d s, and to the interaction between flexural and shear modes of failure.

POPULATION OF SHEAR FAILURES

The twelve tests presented in this paper illustrate the effects of adding steel fibers to reinforced concrete beams. By themselves, however, these data are insufficient to calibrate design expressions for shear strength because the number of tests was too small. Of the nine beams that contained steel fibers, only two failed in pure shear, and two failed in a combination of flexure and shear. The other five beams with fibers, which failed in flexure, provide only a lower bound on the shear strength.

Additional data was compiled from the literature²⁻²¹ to evaluate the existing and proposed equations for shear cracking and strength of rectangular fiber-reinforced concrete beams. Beam tests were added to the database only if the authors described the failures as shear failures, or if crack patterns indicated that this failure mode predominated. In addition, beams without fibers or with conventional transverse reinforcement were omitted; the a/d was limited to a range of 1.0 to 5.5; and the flexural reinforcement ratio needed to be at least 0.5%. For practical purposes, it was also necessary to eliminate a few other tests for which the available references did not provide sufficient information to calibrate expressions for shear strength.

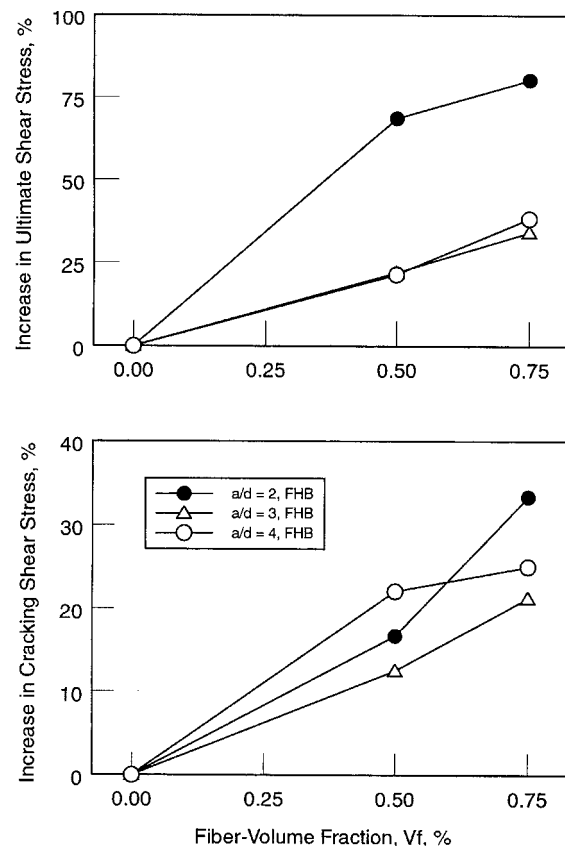

Fig. 5—Influence of fiber volume on increased shear resistance.

Based on these criteria, results were assembled for 139 tests from this study and 11 previous studies.^{3-5,7,9-13,19,21} For 46 of the test specimens, the investigators also reported the average shear stress at the onset of shear cracking.¹¹⁻¹³ Table 4 lists the number of tests that satisfied the screening criteria for each test series.

The test population included tests with a wide range of fiber-volume ratios (0.22 to 2%), a/d s (1.0 to 5.0), concrete compressive strengths (21 to 112 MPa), flexural reinforcement ratios (1.1 to 5.7), and depths (102 to 570 mm). Most of the beams were small, however, and only 12% of the 139 beams had effective depths greater than 250 mm. This observation is important, because the shear strength of a beam—especially one without web reinforcement—is known to decrease with increasing beam depth.^{9,23}

DESIGN EQUATIONS FOR SHEAR STRENGTH

A number of investigators have proposed empirical equations for estimating the average shear stress at shear failure v_u of a fiber-reinforced concrete beam. Statistics on the accuracy of six of these equations are provided in Table 4. For each series, and for the population of 139 tests, the table lists the mean and coefficient of variation of the ratio of the experimentally observed shear to the calculated shear $v_{u,exp}/v_{u,calc}$.

Sharma

Based on the results of his own tests and those of Batson, Jenkins, and Spatney,⁴ Sharma¹⁶ proposed a simple empirical equation for predicting the shear strength of fiber-reinforced concrete beams

$$v_u = kf'_t(d/a)^{0.25} \text{ (MPa)} \quad (1)$$

where

- v_u = average shear stress at shear failure;
- k = 2/3;
- a/d = shear span-depth ratio;
- f'_t = split-cylinder tensile strength of concrete, if known;
- f'_t = $0.79(f'_c)^{0.5}$, MPa, if the tensile strength is unknown; and
- f'_c = concrete cylinder compressive strength.

The simplicity of Eq. (1) makes it attractive, but this equation does not explicitly account for factors that are known to significantly influence the shear strength, including the fiber volume (Fig. 5), the shape of the fibers, and the flexural reinforcement ratio. In addition, Eq. (1) underestimates the effect of a/d . Consequently, Eq. (1) is excessively conservative for low values of a/d and unconservative for high values of a/d (Fig. 6). The mean of the ratio of measured shear strength to calculated shear strength was 1.26 for the 139 tests, and the coefficient of variation of this ratio was 37% (Table 4).

Narayanan and Darwish

Narayanan and Darwish¹³ proposed an empirical equation for the average shear stress at shear failure v_u

$$v_u = e \left[0.24f_{spfc} + 80\rho \frac{d}{a} \right] + v_b \text{ (MPa)} \quad (2)$$

where

- f_{spfc} = computed value of split-cylinder strength of fiber concrete;

$$= f_{cu} / (20 - \sqrt{F}) + 0.7 + 1.0\sqrt{F} \text{ (MPa)} \quad (3)$$

Table 4—Statistical evaluation of expressions for shear strength

Test series	No. of tests	Mean value of $v_{u,exp}/v_{u,calc}$ (coefficient of variation)					
		Sharma	Narayanan	Ashour		Imam	Proposed
		Eq. (1)	Eq. (2)	Eq. (5)	Eq. (6)	Eq. (7)	Eq. (9)
This investigation	4	1.59 (0.15)	1.70 (0.03)	1.83 (0.03)	1.34 (0.04)	1.30 (0.05)	1.33 (0.05)
Ashour, Hasanain, and Wafa ³	11	1.25 (0.40)	1.03 (0.15)	1.17 (0.12)	1.09 (0.10)	0.63 (0.32)	0.86 (0.13)
Batson, Jenkins, and Spatney ⁴	42	0.96 (0.46)	1.10 (0.10)	1.14 (0.11)	1.29 (0.18)	—	1.01 (0.09)
Casanova and Rossi ¹⁹	2	1.45 (0.00)	1.53 (0.00)	1.80 (0.00)	1.44 (0.00)	0.98 (0.00)	1.25 (0.00)
Imam, Vandewalle, and Mortelmans ⁵	5	0.79 (0.37)	1.20 (0.14)	1.53 (0.12)	1.23 (0.16)	0.97 (0.11)	0.99 (0.07)
Kaushik, Gupta, and Tarafdar ⁷	9	1.17 (0.05)	1.11 (0.12)	1.25 (0.11)	0.89 (0.16)	0.76 (0.14)	0.93 (0.08)
Li, Ward, and Hamza ⁹	6	1.26 (0.24)	1.47 (0.15)	1.61 (0.10)	1.20 (0.12)	—	1.32 (0.10)
Lim, Paramasivam, and Lee ¹⁰	7	1.01 (0.36)	0.97 (0.05)	1.08 (0.11)	0.85 (0.10)	0.67 (0.23)	0.82 (0.07)
Mansur, Ong, and Paramasivam ¹¹	9	1.50 (0.15)	1.19 (0.12)	1.29 (0.12)	0.94 (0.13)	0.88 (0.12)	0.98 (0.11)
Murty and Venkatacharyulu ¹²	4	1.30 (0.14)	1.07 (0.09)	1.11 (0.13)	0.82 (0.10)	—	0.85 (0.14)
Narayanan and Darwish ¹³	29	1.54 (0.27)	1.09 (0.15)	1.23 (0.16)	1.00 (0.15)	—	0.97 (0.12)
Noghabai ²¹	11	1.71 (0.17)	1.33 (0.16)	1.52 (0.16)	1.23 (0.16)	1.13 (0.17)	1.07 (0.15)
All tests	139	1.26 (0.37)	1.15 (0.18)	1.27 (0.19)	1.12 (0.21)	0.87 (0.29)	1.00 (0.15)

- ρ = flexural reinforcement ratio;
- F = fiber factor (L_f/D_f) $V_f d_f$;
- e = arch action factor: 1.0 for $a/d > 2.8$, and $2.8 d/a$ for $a/d \leq 2.8$;
- $f_{cu,f}$ = cube strength of fiber concrete, MPa;
- L_f = fiber length;
- D_f = fiber diameter;
- V_f = volume fraction of steel fibers;
- d_f = bond factor: 0.50 for round fibers, 0.75 for crimped fibers, and 1.00 for indented fibers;
- $v_b = 0.41 \tau F$; and
- τ = average fiber matrix interfacial bond stress, taken as 4.15 MPa, based on the recommendations of Swamy, Mangat, and Rao.²⁶

According to the authors, the first term in the brackets in Eq. (2) accounts for the fiber contribution in terms of the split-cylinder strength, the second term accounts for dowel action, and the third term accounts for the contribution of fibers across an inclined crack.¹³ The fiber factor F accounts not only for the fiber volume and aspect ratio but, with the bond factor d_f , also accounts for variations in anchorage conditions of the fibers.

The nondimensional factor e , which accounts for arching action, is similar to the factor in the shear equation proposed by Zsutty²⁴ for conventional beams without fibers

$$v_u = 11.4e(f'_c \rho \frac{d}{a})^{1/3} \text{ (MPa)} \quad (4)$$

where

$e = 1.0$ for $a/d > 2.5$, and $2.5 d/a$ for $a/d \leq 2.5$. In Eq. (2), the transition limit for d/a , which was increased from 2.5 to 2.8, and the values of other constants were determined by regression analysis.

Equation (2) considers the key parameters affecting shear strength, including the volume and shape of the fibers, a/d , the concrete strength, and the flexural reinforcement ratio. Moreover, the regression analysis was carried out only on shear failures so, as shown in Fig. 7, Eq. (2) provided reliable (but conservative) estimates of shear strength. The mean strength ratio was 1.15, and the corresponding coefficient of variation was 18%.

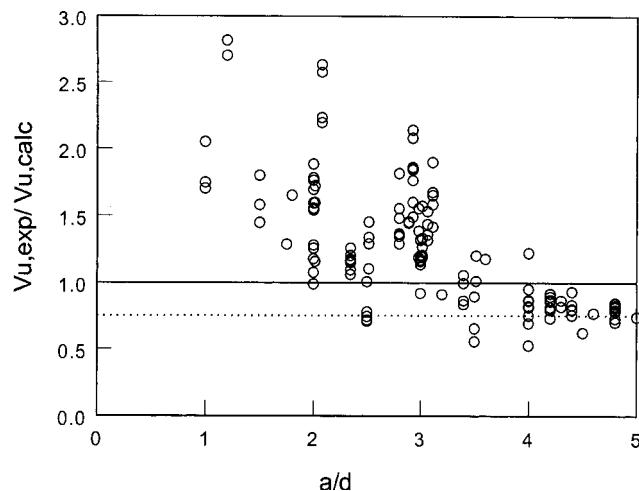

Fig. 6—Evaluation of Sharma's Eq. (1).

Ashour, Hasanain, and Wafa

Ashour, Hasanain and Wafa³ tested 18 beams made of high-strength fiber-reinforced concrete. Based on these results, they proposed two equations for predicting the strengths of such beams. The first set of expressions was similar to Zsutty's Eq. (4),²⁴ but was modified to account for the fibers For $a/d \geq 2.5$,

$$v_u = (2.11 \sqrt[3]{f'_c} + 7F) \left(\rho \frac{d}{a} \right)^{0.333} \text{ (MPa)} \quad (5a)$$

For $a/d < 2.5$,

$$v_u = [\text{Eq. (5a)}] \frac{2.5}{a/d} + v_b \left(2.5 - \frac{a}{d} \right) \text{ (MPa)} \quad (5b)$$

The second equation was similar to Eq. (11-4) in the ACI Building Code,²² but was modified to account for the effect of the fibers

$$v_u = (0.7 \sqrt{f'_c} + 7F) \frac{d}{a} + 17.2 \rho \frac{d}{a} \text{ (MPa)} \quad (6)$$

Equation (5) and (6) include the same parameters that were included in Eq. (2). The constants in Eq. (5) and (6) were determined by regression analysis on Ashour, Hasanain, and Wafa's³ test results and, according to the authors, these equations provided a better fit to their high-strength concrete data than did Narayanan and Darwish's Eq. (2). However, Eq. (5) and (6) were less accurate than Eq. (2) for the larger population of 139 tests. The discrepancy in accuracy stems from the difference in the data sets used to calibrate the equations. In particular, Ashour, Hasanain, and Wafa³ included test results for beams with a flexural reinforcement ratio of 0.37% or an a/d of 6.0, even though they reported that these beams failed in flexure.

Imam and Vandewalle

Imam et al.²⁵ modified an expression that Bažant and Sun²⁷ had developed to predict the shear strength of normal-strength conventional concrete beams. The Bažant and Sun expression was developed based on the results of nonlinear

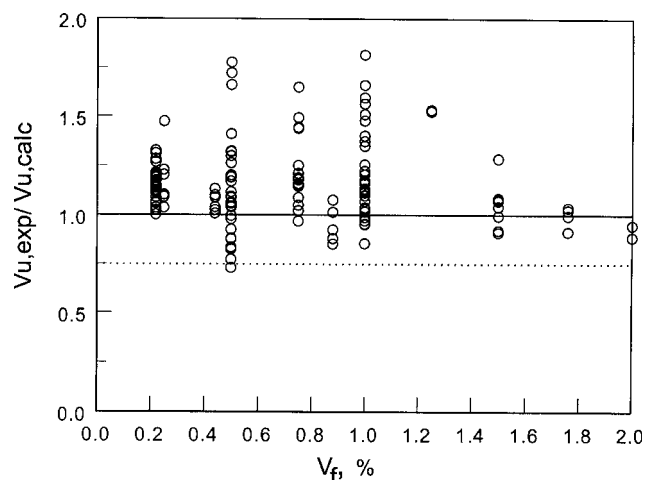

Fig. 7—Evaluation of Narayanan and Darwish's Eq. (2).

fracture mechanics, which indicate that the shear capacity varies with maximum aggregate size d_a and the ratio of beam depth to maximum aggregate size d/d_a . The Imam et al. equation differs from the Bažant and Sun equation only in that the reinforcement factor ω was substituted in place of the flexural reinforcement ratio ρ and the constants were adjusted as the result of statistical analysis.

$$v_u = 0.6\Psi^3\sqrt{\omega}\left[(f_c')^{0.44} + 275\sqrt{\frac{\omega}{(a/d)^5}}\right] \text{ (MPa)} \quad (7)$$

where

Ψ = size effect factor

$$= \frac{1 + \sqrt{(5.08/d_a)}}{\sqrt{1 + d/(25d_a)}};$$

ω = reinforcement factor $\rho(1 + 4F)$;

F = fiber factor $(L_f/D_f) V_f d_f$; and

d_f = bond factor, equal to 0.50 for smooth fibers, 0.9 for deformed fibers, and 1.0 for hooked fibers.

Equation (7) incorporates the key factors of other models,^{3,13} and adds the size effect. This equation, however, was calibrated with only 29 tests of fiber-reinforced concrete beams, of which some failed in flexure rather than shear. The resulting equation was less accurate than Eq. (2), and Eq. (7) was significantly unconservative for the Ashour, Hasanain, and Wafa³ and the Lim, Paramasivam, and Lee¹⁰ tests (Table 4).

Table 5—Statistical evaluation of expressions for cracking shear

Test series	No. of tests	Mean value of $v_{cr,exp}/v_{cr,calc}$ (COV)	
		Proposed Eq. (11)	Narayanan (Eq. (10))
This investigation	4	1.10 (0.08)	1.27 (0.06)
Mansur, Ong, and Paramasivam ¹¹	9	0.92 (0.04)	1.05 (0.07)
Murty and Venkatacharyulu ¹²	4	1.09 (0.12)	1.30 (0.15)
Narayanan and Darwish ¹³	29	1.00 (0.16)	1.12 (0.14)
All tests	46	1.00 (0.14)	1.13 (0.14)

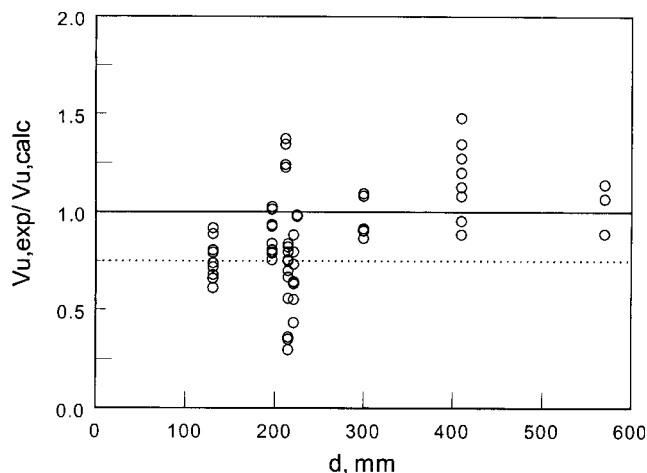

Fig. 8—Evaluation of Imam et al. Eq. (7).

The procedure appears to overcompensate for the effect of depth. As shown in Fig. 8, this equation tends to overestimate the strength of shallow beams and underestimate the strength of deep beams.

Proposed equation

A new equation for shear strength was developed by combining the form of Zsutty's equation to account for the influence of tensile strength on arching action with an additional fiber term to account for the direct contribution of the fibers to shear resistance

$$v_u = Aef_{spfc}^{\exp1}\left(\rho\frac{d}{a}\right)^{\exp2} + Bv_b^{\exp3} \text{ (MPa)} \quad (8)$$

where

v_b = $0.41\tau F$, as defined in Eq. (2).

In this equation, the value of e is equal to 1.0 for $a/d > a/d_{transition}$, and it is equal to $(a/d_{transition}d/a)$ for $a/d \leq a/d_{transition}$. This equation provided a mean of 1.00 for the ratio of measured shear strength to calculated shear strength, and it minimized the coefficient of variation (COV = 14.9%) for the following values of the constants: $A = 2.1$; $B = 0.8$; $a/d_{transition} = 3.5$; $\exp1 = 0.70$; $\exp2 = 0.22$; and $\exp3 = 0.97$.

With little loss of accuracy (COV = 15.3%), Eq. (8) can be written to closely resemble Zsutty's original equation

$$v_u = 3.7ef_{spfc}^{2/3}\left(\rho\frac{d}{a}\right)^{1/3} + 0.8v_b \text{ (MPa)} \quad (9)$$

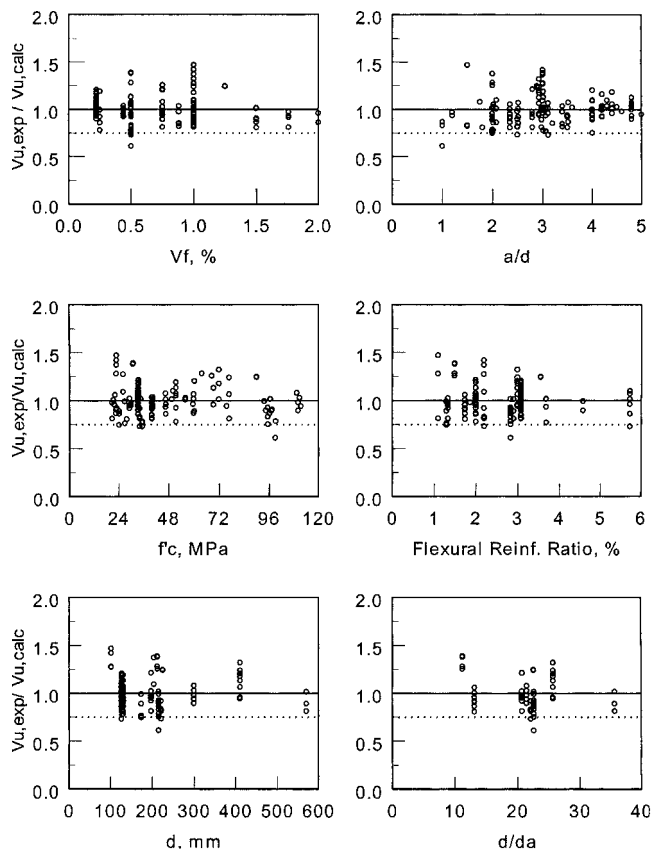

Fig. 9—Evaluation of proposed Eq. (9) for shear strength.

where

$e = 1.0$ for $a/d > 3.4$, and $3.4 d/a$ for $a/d \leq 3.4$.

The ratio of the measured shear strength to the calculated strength for Eq. (9) had a mean of 1.00 and a coefficient of variation of 15.3% (Table 4). In the main body of the ACI 318-99 Building Code,²² the capacity-reduction factor for shear is 0.85. Despite having a mean of 1.00, 84% of the test beams had capacities that exceeded 0.85 times the calculated capacity. According to the ACI 318-02 Building Code,²⁸ the capacity-reduction for shear is 0.75. Ninety-seven percent of the beams had capacities that exceeded 0.75 times the calculated capacity.

Figure 9 shows that the proposed equation accurately accounts for the effects of the fiber-volume percentage, a/d , concrete compressive strength, flexural reinforcement ratio, beam depth d , and beam-depth-to-aggregate size ratio d/d_a . In particular, the accuracy of Eq. (9) did not vary with d or d/d_a . Size effects may be less significant for fiber-reinforced concrete beams than for conventional beams, because the failure modes are more ductile in fiber-reinforced beams. It is also possible that size effects were not apparent in the results, because most of the beams were small.

For beams without fibers, Eq. (9) is similar to Zsutty's Eq. (4) and provides reasonable estimates of shear strength. For beams without fibers, Eq. (9) differs from Eq. (4) only in that tensile strength replaces compressive strength and the value of the empirical constant changes. Equation (9) was applied (setting V_f equal to 0.0) to 40 previous tests of beams without fibers^{4-6,11,13,17,20,21} and to the three beams without fibers described in Table 1. For these beams, the mean ratio of measured to calculated shear strength was 1.06, with a coefficient of variation of 32%.

EQUATIONS FOR SHEAR CRACKING

Narayanan and Darwish¹³ proposed an empirical equation for estimating the average shear stress at the onset of shear cracking v_{cr} , which is defined as the shear divided by the beam's width and effective depth

$$v_{cr} = 0.24f_{spfc} + 20\rho\frac{d}{a} + 0.5F \text{ (MPa)} \quad (10)$$

Following a procedure similar to that followed to develop Eq. (9), a simpler equation was proposed

$$v_{cr} = 3(f_{spfc})^{2/3}\left(\rho\frac{d}{a}\right)^{1/3} \text{ (MPa)} \quad (11)$$

Equation (10) and (11) were evaluated for the 46 tests for which observations of cracking shear were available (Table 5). The accuracy of both equations was similar, but the proposed equation is simpler.

SUMMARY AND CONCLUSIONS

The experimental results from 12 fiber-reinforced concrete beams demonstrate the influence of steel-fiber volume fraction; a/d ; and concrete compressive strength on the onset of shear cracking, shear strength, ultimate deflection, and failure mode. The increase in strength was particularly large (69 to 80%) for beams with the smallest a/d s ($a/d = 2$), which failed in a combination of shear and flexure. The increases in beam strength were smaller (22 to 38%) for beams with larger a/d s, which failed in flexure. The addition of steel fibers consistently

decreased crack spacings and sizes, increased deformation capacity, and changed a brittle mode to a ductile one.

The results of 139 tests of fiber-reinforced concrete beams that failed in shear were analyzed to evaluate the accuracy of six design equations for shear strength. Of the existing procedures, the procedure proposed by Narayanan and Darwish¹³ was the most accurate. The procedures proposed in this study (Eq. (9) and (11)) further improve the accuracy of estimates of the shear strength and the onset of shear cracking. For the proposed equation, the mean value of the ratio of the measured to calculated shear strength was 1.00, and the coefficient of variation was 15%. The proposed equation also provides reasonable results for beams without fibers.

The accuracy of the shear-strength estimate did not vary with beam depth (Fig. 9). This insensitivity may be attributable to the increased ductility of fiber-reinforced concrete as compared with conventional concrete. Alternatively, the apparent lack of size effect may be a consequence of the test population, which is dominated by small beams.

ACKNOWLEDGMENTS

The authors wish to thank the Kum-Oh National University of Technology for granting Professor Kwak a sabbatical leave to undertake this research at the University of Washington.

NOTATION

a/d	=	shear span-depth ratio
b	=	beam width, mm
d	=	effective depth of beam, mm
d_a	=	maximum aggregate size, mm
d_f	=	bond factor
D_f	=	fiber diameter, mm
E_c	=	modulus of elasticity of concrete, MPa
F	=	fiber factor
f'_c	=	cylinder compressive strength of concrete, MPa
f_{cuf}	=	cube strength of fiber concrete, MPa
f_r	=	modulus of rupture of concrete, MPa
f_{sp}	=	cylinder splitting strength of concrete, MPa
f_{spfc}	=	computed value of split-cylinder strength of fiber concrete, MPa
l_f	=	fiber length, mm
l_f/D_f	=	fiber aspect ratio
v_{cr}	=	average shear stress at shear cracking, MPa
v_u	=	average ultimate shear strength, MPa
ρ	=	flexural steel reinforcement ratio
τ	=	average fiber matrix interfacial bond stress (4.15 MPa)
ω	=	reinforcement factor
ψ	=	size effect factor

REFERENCES

1. ACI Committee 544, "State-of-the-Art Report on Fiber Reinforced Concrete (ACI 544.1R-96)," American Concrete Institute, Farmington Hills, Mich., 1997, pp. 1-60.
2. Adebar, P.; Mindess, S.; St.-Pierre, D.; and Olund, B., "Shear Tests of Fiber Concrete Beams without Stirrups," *ACI Structural Journal*, V. 94, No. 1, Jan.-Feb. 1997, pp. 68-76.
3. Ashour, S. A.; Hasanain, G. S.; and Wafa, F. F., "Shear Behavior of High-Strength Fiber Reinforced Concrete Beams," *ACI Structural Journal*, V. 89, No. 2, Mar.-Apr. 1992, pp. 176-184.
4. Batson, G.; Jenkins, E.; and Spatney, R., "Steel Fibers as Shear Reinforcement in Beams," *ACI JOURNAL, Proceedings* V. 69, No. 10, Oct. 1972, pp. 640-644.
5. Imam, M.; Vandewalle, L.; and Mortelmans, F., "Shear Capacity of Steel Fiber High-Strength Concrete Beams," *High-Performance Concrete*, SP-149, V. M. Malhotra, ed., American Concrete Institute, Farmington Hills, Mich., 1994, pp. 227-241.
6. Jindal, R. L., "Shear and Moment Capacities of Steel Fiber Reinforced Concrete Beams," *Fiber Reinforced Concrete*, SP-81, G. C. Hoff, ed., American Concrete Institute, Farmington Hills, Mich., 1984, pp. 1-16.
7. Kaushik, S. K.; Gupta, V. K.; and Tarafdar, N. K., "Behavior of Fiber Reinforced Concrete Beams in Shear," *Proceedings of the International Symposium on Fiber Reinforced Concrete*, Madras, India, Dec. 1987, pp. 1.133-1.149.
8. LaFraugh, R. W., and Moustafa, S. E., *Experimental Investigation of*

the Use of Steel Fibers for Shear Reinforcement, Concrete Technology Association, Tacoma, Jan. 1975, 53 pp.

9. Li, V. C.; Ward, R.; and Hamza, A. M., "Steel and Synthetic Fibers as Shear Reinforcement," *ACI Materials Journal*, V. 89, No. 5, Sept.-Oct. 1992, pp. 499-508.

10. Lim, T. Y.; Paramasivam, P.; and Lee, S. L., "Shear and Moment Capacity of Reinforced Steel Fiber Concrete Beams," *Magazine of Concrete Research*, V. 39, No. 140, Sept. 1987, pp. 148-160.

11. Mansur, M. A.; Ong, K. C. G.; and Paramasivam, P., "Shear Strength of Fibrous Concrete Beams without Stirrups," *Journal of Structural Engineering*, ASCE, V. 112, No. 9, Sept. 1986, pp. 2066-2079.

12. Murty, D. S. R., and Venkatacharyulu, T., "Fiber Reinforced Concrete Beams Subjected to Shear Force," *Proceedings of the International Symposium on Fiber Reinforced Concrete*, Madras, India, Dec. 1987, pp. 1.125-1.132.

13. Narayanan, R., and Darwish, I. Y. S., "Use of Steel Fibers as Shear Reinforcement," *ACI Structural Journal*, V. 84, No. 3, May-June 1987, pp. 216-227.

14. Narayanan, R., and Darwish, I. Y. S., "Fiber Concrete Deep Beams in Shear," *ACI Structural Journal*, V. 85, No. 2, Mar.-Apr. 1988, pp. 141-149.

15. Roberts, T. M., and Ho, N. L., "Shear Failure of Deep Fiber Reinforced Concrete Beams," *International Journal of Cement Composites and Lightweight Concrete*, V. 4, No. 3, Aug. 1982, pp. 145-152.

16. Sharma, A. K., "Shear Strength of Steel Fiber Reinforced Concrete Beams," *ACI JOURNAL, Proceedings* V. 83, No. 4, July-Aug. 1986, pp. 624-628.

17. Swamy, R. N., and Bahia, H. M., "The Effectiveness of Steel Fibers as Shear Reinforcement," *Concrete International*, V. 7, No. 3, Mar. 1985, pp. 35-40.

18. Williamson, G. R., and Knab, L. I., "Full Scale Fibre Concrete Beam Tests," *Proceedings, RILEM Symposium on Fiber Reinforced Cement*

Concrete, London, Construction Press, Lancaster, 1975, pp. 209-214.

19. Casanova, P., and Rossi, P., "High-Strength Concrete Beams Submitted to Shear: Steel Fibers versus Stirrups," *Structural Applications of Fiber Reinforced Concrete*, SP-182, N. Banthia, C. MacDonald, and P. Tatnall, eds., American Concrete Institute, Farmington Hills, Mich., 1999, pp. 53-67.

20. Lim, D. H., and Oh, B. H., "Experimental and Theoretical Investigation on the Shear of Steel Fibre Reinforced Concrete Beams," *Engineering Structures*, 1999, pp. 937-944.

21. Noghabai, K., "Beams of Fibrous Concrete in Shear and Bending: Experiment and Model," *Journal of Structural Engineering*, ASCE, V. 126, No. 2, Feb. 2000, pp. 243-251.

22. ACI Committee 318, "Building Code Requirements for Structural Concrete (ACI 318-99) and Commentary (318R-99)," American Concrete Institute, Farmington Hills, Mich., 1999, 391 pp.

23. MacGregor, J. G., *Reinforced Concrete: Mechanics and Design*, Prentice-Hall Inc., Upper Saddle River, N. J., 1997.

24. Zsutty, T., "Shear Strength Prediction for Separate Categories of Simple Beam Tests," *ACI JOURNAL, Proceedings* V. 68, No. 2, Feb. 1971, pp. 138-143.

25. Imam, M.; Vandewalle, L.; Mortelmans, F.; and Van Gemert, D., "Shear Domain of Fibre Reinforced High-Strength Concrete Beams," *Engineering Structures*, V. 19, No. 9, 1997, pp. 738-747.

26. Swamy, R. N.; Mangat, P. S.; and Rao, C. V. S. K., "The Mechanics of Fiber Reinforcement of Cement Matrices," *Fiber Reinforced Concrete*, SP-44, American Concrete Institute, Farmington Hills, Mich., 1974, pp. 1-28.

27. Bazant, Z. P., and Sun, H.-H., "Size Effect on Diagonal Shear Failure: Influence of Aggregate Size and Stirrups," *ACI Materials Journal*, V. 84, No. 4, July-Aug. 1987, pp. 259-272.

28. ACI Committee 318, "Building Code Requirements for Structural Concrete (ACI 318-02) and Commentary (318R-02)," American Concrete Institute, Farmington Hills, Mich., 2002, 443 pp.