

Discretization of State-Space System Models

Xu Chen

University of Washington



1TB vs 1,300 filing cabinets of paper

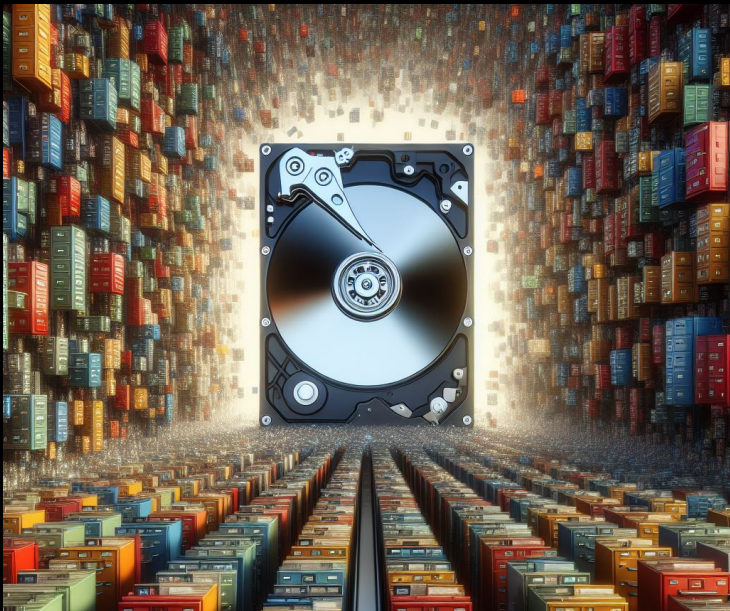

Inherent sampling in practice



$$\Delta t = \frac{1}{(\text{rpm}/60) \times \text{sector number}}$$

Practical control systems

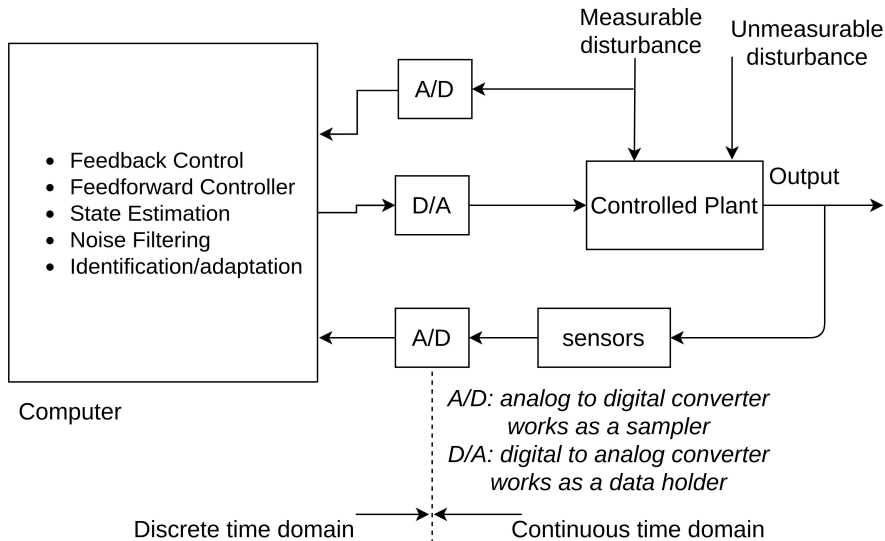

Sampler

- ▶ sampler: converts a time function into a discrete sequence,

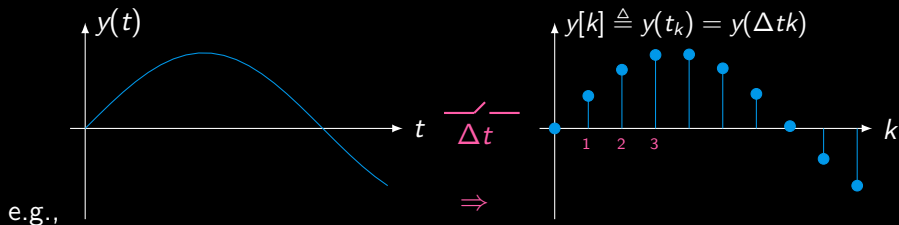

Signal holding

- ▶ Zero-order Hold (ZOH): converts a sequence into a “stair-case” time function, e.g.,

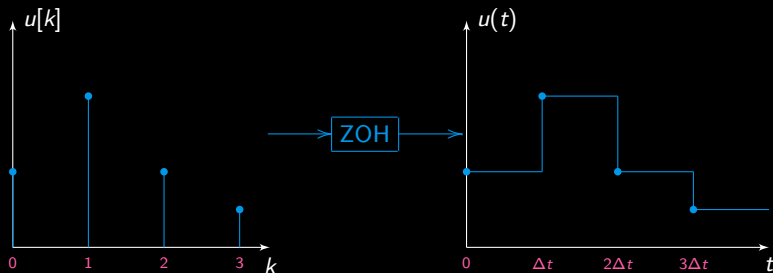

- ▶ $u(t) = u[k]$ for $t \in [k\Delta t, (k+1)\Delta t)$

Signal holding

- ▶ more faithful presentation with fast sampling

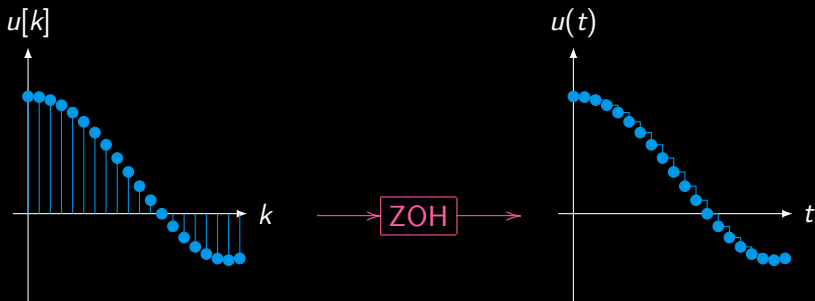

Problem definition

continuous-time system preceded by a ZOH:

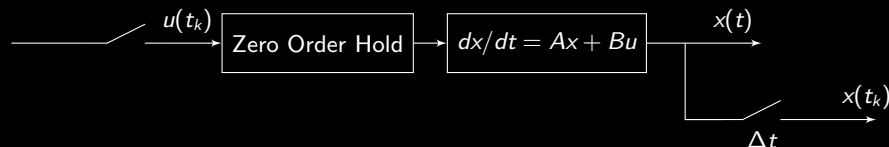

- ▶ $u(t_k)$: discrete-time input
- ▶ $x(t)$: continuous-time output
- ▶ $x(t_k)$: sampled discrete-time output
- ▶ Δt : sampling time
- ▶ goal: to obtain the model between $u(t_k)$ and $x(t_k)$

Solution

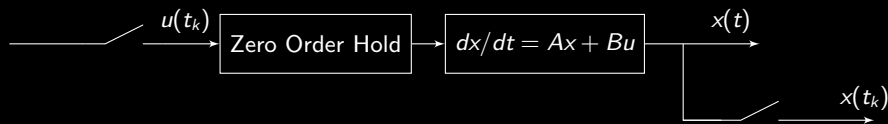

- ▶ starting from t_k , the solution of $\dot{x} = Ax + Bu$ at time t_{k+1} is

$$\begin{aligned}x(t_{k+1}) &= e^{A(t_{k+1}-t_k)}x(t_k) + \int_{t_k}^{t_{k+1}} e^{A(t_{k+1}-\tau_0)}Bu(\tau_0)d\tau_0 \\ &= e^{A\overbrace{(t_{k+1}-t_k)}^{\Delta t}}x(t_k) + u(t_k) \underbrace{\int_{t_k}^{t_{k+1}} e^{A\overbrace{(t_{k+1}-\tau_0)}^{\eta}}Bd\tau_0}_{= \int_{\Delta t}^0 e^{A\eta}Bd(-\eta) = -\int_{\Delta t}^0 e^{A\eta}Bd\eta}\end{aligned}$$

- ▶ noting $-\int_{\Delta t}^0 e^{A\eta}Bd\eta = \int_0^{\Delta t} e^{A\tau}Bd\tau$ and denoting t_k as k yield

$$x[k+1] = A_d x[k] + B_d u[k], \quad A_d = e^{A\Delta t}, \quad B_d = \int_0^{\Delta t} e^{A\tau} B d\tau$$

Mapping of eigenvalues

$$x[k+1] = A_d x[k] + B_d u[k], \quad A_d = e^{A\Delta t}, \quad B_d = \int_0^{\Delta t} e^{A\tau} B d\tau$$

- ▶ diagonalization / Jordan form: $A = T^{-1}\Lambda T$
- ▶ e^{At} has the same eigenvalues as $e^{\Lambda t}$
- ▶ \Rightarrow eigenvalues of $A_d = e^{A\Delta t}$ are $e^{\lambda_i \Delta t}$'s where λ_i is an eigenvalue of A

Example

$$\dot{x}(t) = \underbrace{\begin{bmatrix} 0 & 1 \\ 0 & 0 \end{bmatrix}}_A x(t) + \underbrace{\begin{bmatrix} 0 \\ 1 \end{bmatrix}}_B u(t)$$
$$y(t) = \underbrace{\begin{bmatrix} 1/m & 0 \end{bmatrix}}_C x(t)$$

discretization at a sampling time of $\Delta t \Rightarrow$

$$A_d = e^{A\Delta t} = \begin{bmatrix} 1 & \Delta t \\ 0 & 1 \end{bmatrix}, \quad B_d = \int_0^{\Delta t} e^{A\tau} B d\tau = \int_0^{\Delta t} \begin{bmatrix} \tau \\ 1 \end{bmatrix} d\tau = \begin{bmatrix} \frac{\Delta t^2}{2} \\ \Delta t \end{bmatrix}$$

$$C_d = C$$

Numerical example in Python

```
import control
import numpy
m = 1
dt = 0.1
A = [[0, 1], [0, 0]]
B = [[0], [1]]
C = [[1/m, 0]]
D = 0

G_s = control.ss(A, B, C, D)
G_z = control.c2d(G_s, dt, 'zoh')
print(G_z.A)

# eigenvalues of continuous-time system
eigA, eigvecA = numpy.linalg.eig(A)
print(eigA)
# eigenvalues of discretized system
eigAd, eigvecAd = numpy.linalg.eig(G_z.A)
print(eigAd)
```

Spectral mapping theorem

- ▶ eigenvalues of $A_d = e^{AT}$ are $e^{\lambda_i T}$'s where λ_i is an eigenvalue of A
- ▶ more generally: take any $X \in \mathbb{C}^{n \times n}$ and a polynomial function $f(\cdot)$ (more generally, analytic functions)
- ▶ e.g.:

$$A = \begin{bmatrix} 99.8 & 2000 \\ -2000 & 99.8 \end{bmatrix} = 99.8I + 2000 \overbrace{\begin{bmatrix} 0 & 1 \\ -1 & 0 \end{bmatrix}}^X$$

- ▶ then

$$\text{eig}(f(X)) = f(\text{eig}(X))$$

- ▶ e.g.:

$$A = \begin{bmatrix} 99.8 & 2000 \\ -2000 & 99.8 \end{bmatrix} = 99.8I + 2000 \begin{bmatrix} 0 & 1 \\ -1 & 0 \end{bmatrix}$$
$$\lambda(A) = 99.8 + 2000\lambda \left\{ \begin{bmatrix} 0 & 1 \\ -1 & 0 \end{bmatrix} \right\} = 99.8 \pm 2000i$$

Spectral mapping theorem

$$A = \begin{bmatrix} 99.8 & 2000 \\ -2000 & 99.8 \end{bmatrix}$$

```
import numpy
A = [[99.8, 2000], [-2000, 99.8]]

eigA, eigvecA = numpy.linalg.eig(A)
print(eigA)
```

```
[99.8+2000.j 99.8-2000.j]
```