

Canonical Forms of State-Space Systems

Xu Chen

University of Washington



Goal

the realization problem:

$$\boxed{G(s) = \frac{B(s)}{A(s)}} \xrightarrow{?} \boxed{\Sigma = \left[\begin{array}{c|c} A & B \\ \hline C & D \end{array} \right]}$$

- ▶ existence and uniqueness: the same system can have infinite amount of state-space representations: e.g.

$$\begin{cases} \dot{x} = Ax + Bu \\ y = Cx \end{cases} \quad \begin{cases} \dot{x} = Ax + \frac{1}{2}Bu \\ y = 2Cx \end{cases}$$

- ▶ canonical realizations exist
- ▶ relationship between different realizations?
- ▶ unit problem:

$$G(s) = \frac{b_2s^2 + b_1s + b_0}{s^3 + a_2s^2 + a_1s + a_0}$$

Recall

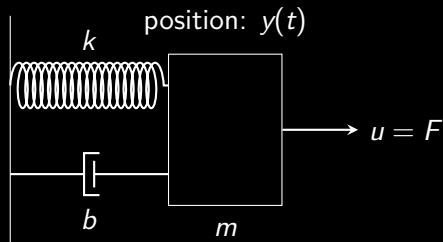

- ▶ $G(s) = \frac{1}{ms^2 + bs + k}$
- ▶ chose position $y(t)$ and velocity $\dot{y}(t)$ as state variables

From spring mass damper to modules with unity numerator

$$u \longrightarrow \boxed{\frac{1}{s^3 + a_2 s^2 + a_1 s + a_0}} \longrightarrow y$$

► choose similarly:

$$x_1 = y, \quad x_2 = \dot{x}_1 = \dot{y}, \quad x_3 = \dot{x}_2 = \ddot{y}$$

► \Rightarrow

$$\frac{d}{dt} \begin{bmatrix} x_1 \\ x_2 \\ x_3 \end{bmatrix} = \begin{bmatrix} 0 & 1 & 0 \\ 0 & 0 & 1 \\ -a_0 & -a_1 & -a_2 \end{bmatrix} \begin{bmatrix} x_1 \\ x_2 \\ x_3 \end{bmatrix} + \begin{bmatrix} 0 \\ 0 \\ 1 \end{bmatrix} u$$

$$y = \begin{bmatrix} 1 & 0 & 0 \end{bmatrix} \begin{bmatrix} x_1 \\ x_2 \\ x_3 \end{bmatrix}$$

Controllable canonical form (ccf)

$$u \longrightarrow \boxed{\frac{b_2 s^2 + b_1 s + b_0}{s^3 + a_2 s^2 + a_1 s + a_0}} \longrightarrow y$$

- ▶ choose x_1 such that

$$u \longrightarrow \boxed{\frac{1}{s^3 + a_2 s^2 + a_1 s + a_0}} \xrightarrow{x_1} \boxed{b_2 s^2 + b_1 s + b_0} \longrightarrow y$$

- ▶ the first part

$$u \longrightarrow \boxed{\frac{1}{s^3 + a_2 s^2 + a_1 s + a_0}} \longrightarrow \tilde{y} (= x_1)$$

is now familiar

Controllable canonical form (ccf)

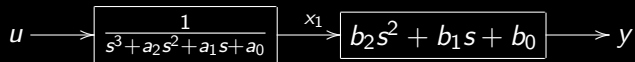

$$X_1(s) = \frac{U(s)}{s^3 + a_2s^2 + a_1s + a_0} \Rightarrow \ddot{x}_1 + a_2\dot{x}_1 + a_1x_1 + a_0x_1 = u$$

► let $x_2 = \dot{x}_1$, $x_3 = \dot{x}_2 \Rightarrow \dot{x}_3 = -a_2x_3 - a_1x_2 - a_0x_1 + u$

► \Rightarrow

$$\frac{d}{dt} \begin{bmatrix} x_1(t) \\ x_2(t) \\ x_3(t) \end{bmatrix} = \begin{bmatrix} 0 & 1 & 0 \\ 0 & 0 & 1 \\ -a_0 & -a_1 & -a_2 \end{bmatrix} \begin{bmatrix} x_1(t) \\ x_2(t) \\ x_3(t) \end{bmatrix} + \begin{bmatrix} 0 \\ 0 \\ 1 \end{bmatrix} u(t)$$

Controllable canonical form (ccf)

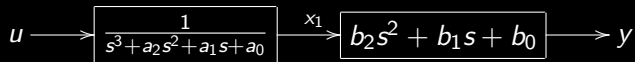

$$X_1(s) = \frac{U(s)}{s^3 + a_2s^2 + a_1s + a_0} \Rightarrow \ddot{x}_1 + a_2\dot{x}_1 + a_1x_1 + a_0x_1 = u$$

- ▶ let $x_2 = \dot{x}_1$, $x_3 = \dot{x}_2 \Rightarrow \dot{x}_3 = -a_2x_3 - a_1x_2 - a_0x_1 + u$
- ▶ for the output:

$$Y(s) = (b_2s^2 + b_1s + b_0) X_1(s) \Rightarrow y = b_2 \underbrace{\ddot{x}_1}_{x_3} + b_1 \underbrace{\dot{x}_1}_{x_2} + b_0x_1$$

▶ \Rightarrow

$$y(t) = \begin{bmatrix} b_0 & b_1 & b_2 \end{bmatrix} \begin{bmatrix} x_1(t) \\ x_2(t) \\ x_3(t) \end{bmatrix}$$

Controllable canonical form (ccf)

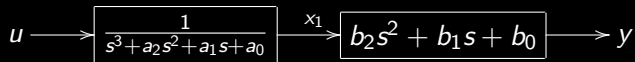

- ▶ $x_2 = \dot{x}_1, x_3 = \dot{x}_2$
- ▶ $y = b_2 \underbrace{\ddot{x}_1}_{x_3} + b_1 \underbrace{\dot{x}_1}_{x_2} + b_0 x_1$
- ▶ putting everything in matrix form:

$$\frac{d}{dt} \begin{bmatrix} x_1(t) \\ x_2(t) \\ x_3(t) \end{bmatrix} = \begin{bmatrix} 0 & 1 & 0 \\ 0 & 0 & 1 \\ -a_0 & -a_1 & -a_2 \end{bmatrix} \begin{bmatrix} x_1(t) \\ x_2(t) \\ x_3(t) \end{bmatrix} + \begin{bmatrix} 0 \\ 0 \\ 1 \end{bmatrix} u(t)$$
$$y(t) = \begin{bmatrix} b_0 & b_1 & b_2 \end{bmatrix} \begin{bmatrix} x_1(t) \\ x_2(t) \\ x_3(t) \end{bmatrix}$$

Block diagram realization of ccf

$$\frac{d}{dt} \begin{bmatrix} x_1(t) \\ x_2(t) \\ x_3(t) \end{bmatrix} = \begin{bmatrix} 0 & 1 & 0 \\ 0 & 0 & 1 \\ -a_0 & -a_1 & -a_2 \end{bmatrix} \begin{bmatrix} x_1(t) \\ x_2(t) \\ x_3(t) \end{bmatrix} + \begin{bmatrix} 0 \\ 0 \\ 1 \end{bmatrix} u(t)$$

$$y(t) = \begin{bmatrix} b_0 & b_1 & b_2 \end{bmatrix} \begin{bmatrix} x_1(t) \\ x_2(t) \\ x_3(t) \end{bmatrix}$$

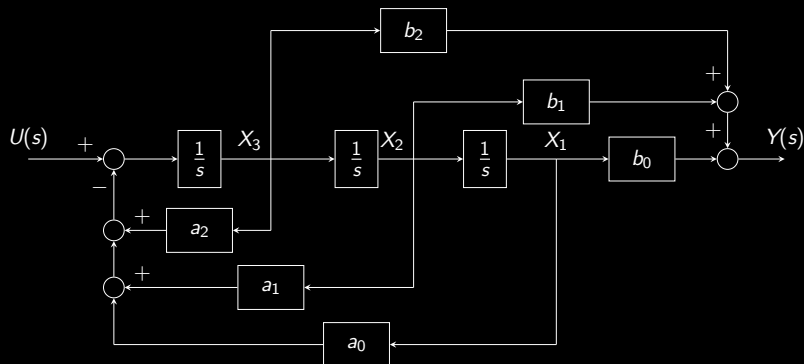

General ccf

general single-input single-output transfer function:

$$G(s) = \frac{b_{n-1}s^{n-1} + \dots + b_1s + b_0}{s^n + a_{n-1}s^{n-1} + \dots + a_1s + a_0} + d$$

► the following realizes $G(s)$

$$\Sigma_c = \left[\begin{array}{c|c} A_c & B_c \\ \hline C_c & D_c \end{array} \right] = \left[\begin{array}{ccccc|c} 0 & 1 & 0 & \dots & 0 & 0 \\ 0 & 0 & \ddots & \ddots & \vdots & 0 \\ \vdots & \vdots & \ddots & \ddots & 0 & \vdots \\ 0 & 0 & \dots & 0 & 1 & 0 \\ -a_0 & -a_1 & \dots & -a_{n-2} & -a_{n-1} & 1 \\ \hline b_0 & b_1 & \dots & b_{n-2} & b_{n-1} & d \end{array} \right]$$

► this realization is called the *controllable canonical form*

ccf example

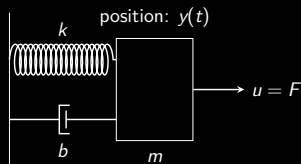

$$\frac{d}{dt} \underbrace{\begin{bmatrix} y(t) \\ v(t) \end{bmatrix}}_{x(t)} = \underbrace{\begin{bmatrix} 0 & 1 \\ -\frac{k}{m} & -\frac{b}{m} \end{bmatrix}}_A \underbrace{\begin{bmatrix} y(t) \\ v(t) \end{bmatrix}}_{x(t)} + \underbrace{\begin{bmatrix} 0 \\ \frac{1}{m} \end{bmatrix}}_B u(t)$$
$$y(t) = \underbrace{\begin{bmatrix} 1 & 0 \end{bmatrix}}_C \underbrace{\begin{bmatrix} y(t) \\ v(t) \end{bmatrix}}_{x(t)}$$

a slightly modified form of the ccf \Rightarrow

$$G(s) = \frac{1}{m} \frac{1}{s^2 + \frac{b}{m}s + \frac{k}{m}} = \frac{1}{ms^2 + bs + k}$$

Observable canonical form (ocf)

$$Y(s) = \frac{b_2 s^2 + b_1 s + b_0}{s^3 + a_2 s^2 + a_1 s + a_0} U(s)$$

$$\Rightarrow Y(s) = -\frac{a_2}{s} Y(s) - \frac{a_1}{s^2} Y(s) - \frac{a_0}{s^3} Y(s) + \frac{b_2}{s} U(s) + \frac{b_1}{s^2} U(s) + \frac{b_0}{s^3} U(s)$$

in a block diagram, the above looks like

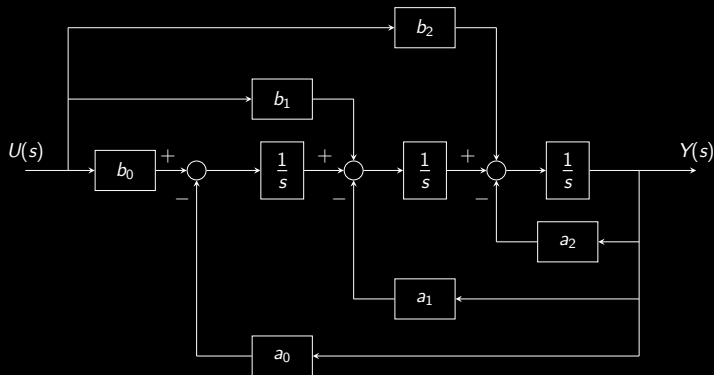

Observable canonical form

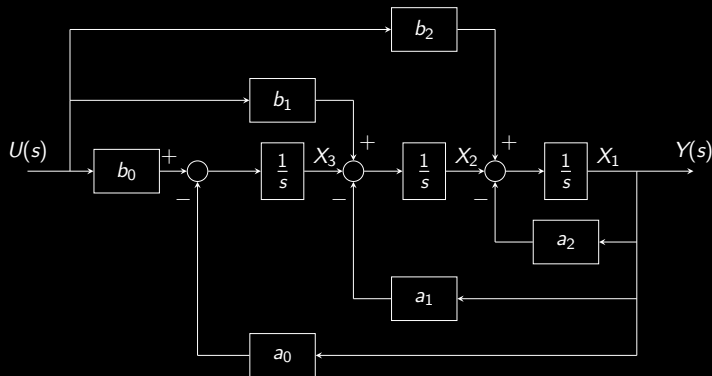

here, the states are connected by

$$\begin{aligned} Y(s) &= X_1(s) & y(t) &= x_1(t) \\ sX_1(s) &= -a_2X_1(s) + X_2(s) + b_2U(s) & \dot{x}_1(t) &= -a_2x_1(t) + x_2(t) + b_2u(t) \\ sX_2(s) &= -a_1X_1(s) + X_3(s) + b_1U(s) & \dot{x}_2(t) &= -a_1x_1(t) + x_3(t) + b_1u(t) \\ sX_3(s) &= -a_0X_1(s) + b_0U(s) & \dot{x}_3(t) &= -a_0x_1(t) + b_0u(t) \end{aligned} \Rightarrow$$

Observable canonical form

$$\begin{cases} \dot{x}_1(t) &= -a_2 x_1(t) + x_2(t) + b_2 u(t) \\ \dot{x}_2(t) &= -a_1 x_1(t) + x_3(t) + b_1 u(t) \\ \dot{x}_3(t) &= -a_0 x_1(t) + b_0 u(t) \\ y(t) &= x_1(t) \end{cases}$$

$$\Rightarrow \dot{x}(t) = \underbrace{\begin{bmatrix} -a_2 & 1 & 0 \\ -a_1 & 0 & 1 \\ -a_0 & 0 & 0 \end{bmatrix}}_{A_o} x(t) + \underbrace{\begin{bmatrix} b_2 \\ b_1 \\ b_0 \end{bmatrix}}_{B_o} u(t)$$

$$y(t) = \underbrace{\begin{bmatrix} 1 & 0 & 0 \end{bmatrix}}_{C_o} x(t)$$

this is called the *observable canonical form* realization of $G(s)$

General ocf

general case for:

$$G(s) = \frac{b_{n-1}s^{n-1} + \dots + b_1s + b_0}{s^n + a_{n-1}s^{n-1} + \dots + a_1s + a_0} + d$$

observable canonical form:

$$\Sigma_o = \left[\begin{array}{c|c} A_o & B_o \\ \hline C_o & D_o \end{array} \right] = \left[\begin{array}{ccccc|c} -a_{n-1} & 1 & 0 & \dots & 0 & b_{n-1} \\ -a_{n-2} & 0 & \ddots & \ddots & \vdots & b_{n-2} \\ \vdots & \vdots & \ddots & \ddots & 0 & \vdots \\ -a_1 & 0 & \dots & 0 & 1 & b_1 \\ -a_0 & 0 & \dots & 0 & 0 & b_0 \\ \hline 1 & 0 & \dots & 0 & 0 & d \end{array} \right]$$

ocf in Python

```
import control as ct
Gs = ct.tf2ss([1,0,1],[1,2,10])
Gc, T = ct.canonical_form(Gs, 'observable')

Gc.A
Gc.B
Gc.C
Gc.D
```

ccf and ocf: no direct Matlab commands

Diagonal form

$$G(s) = \frac{B(s)}{A(s)} = \frac{b_2s^2 + b_1s + b_0}{s^3 + a_2s^2 + a_1s + a_0}$$

when the poles $p_1 \neq p_2 \neq p_3$, partial fractional expansion yields

$$G(s) = \frac{k_1}{s - p_1} + \frac{k_2}{s - p_2} + \frac{k_3}{s - p_3}, \quad k_i = \lim_{p \rightarrow p_i} (s - p_i) \frac{B(s)}{A(s)}$$

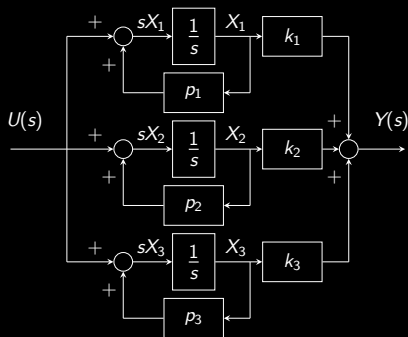

Diagonal form

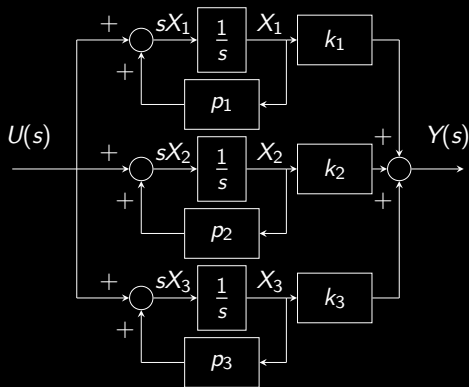

state-space realization:

$$A = \begin{bmatrix} p_1 & 0 & 0 \\ 0 & p_2 & 0 \\ 0 & 0 & p_3 \end{bmatrix}, \quad B = \begin{bmatrix} 1 \\ 1 \\ 1 \end{bmatrix}, \quad C = [k_1 \quad k_2 \quad k_3], \quad D = 0$$

Jordan form

if poles repeat, say,

$$G(s) = \frac{b_2 s^2 + b_1 s + b_0}{s^3 + a_2 s^2 + a_1 s + a_0} = \frac{b_2 s^2 + b_1 s + b_0}{(s - p_1)(s - p_m)^2}, \quad p_1 \neq p_m \in \mathbb{R}$$

then partial fraction expansion gives

$$G(s) = \frac{k_1}{s - p_1} + \frac{k_2}{(s - p_m)^2} + \frac{k_3}{s - p_m} \quad \text{w/} \quad \begin{cases} k_1 &= \lim_{s \rightarrow p_1} G(s)(s - p_1) \\ k_2 &= \lim_{s \rightarrow p_m} G(s)(s - p_m)^2 \\ k_3 &= \lim_{s \rightarrow p_m} \frac{d}{ds} \{G(s)(s - p_m)^2\} \end{cases}$$

Jordan form

$$G(s) = \frac{k_1}{s - p_1} + \frac{k_2}{(s - p_m)^2} + \frac{k_3}{s - p_m}$$

has the block diagram realization:

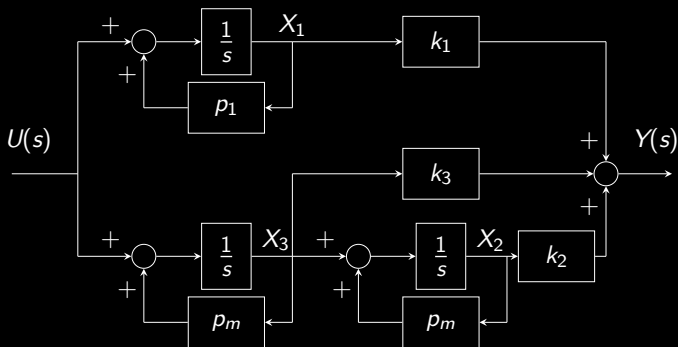

Jordan form

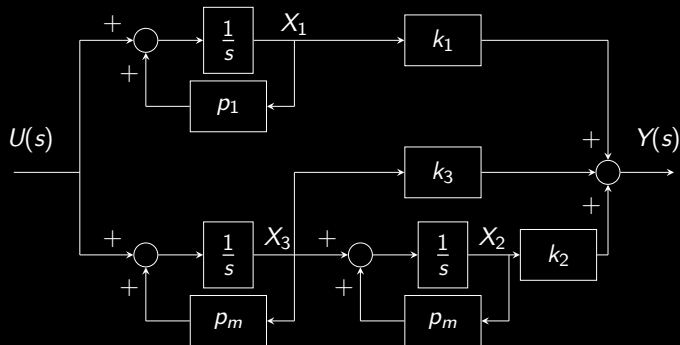

state-space realization (called the Jordan canonical form):

$$A = \begin{bmatrix} p_1 & 0 & 0 \\ 0 & p_m & 1 \\ 0 & 0 & p_m \end{bmatrix}, \quad B = \begin{bmatrix} 1 \\ 0 \\ 1 \end{bmatrix}, \quad C = [k_1 \quad k_2 \quad k_3], \quad D = 0$$

Modified canonical form

if the system has complex poles, say,

$$G(s) = \frac{b_2 s^2 + b_1 s + b_0}{s^3 + a_2 s^2 + a_1 s + a_0} = \frac{k_1}{s - p_1} + \frac{\alpha s + \beta}{(s - \sigma)^2 + \omega^2}$$

then

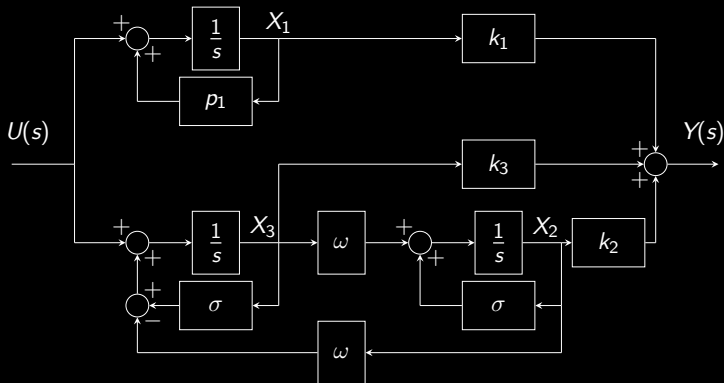

where $k_2 = (\beta + \alpha\sigma)/\omega$ and $k_3 = \alpha$

Modified canonical form

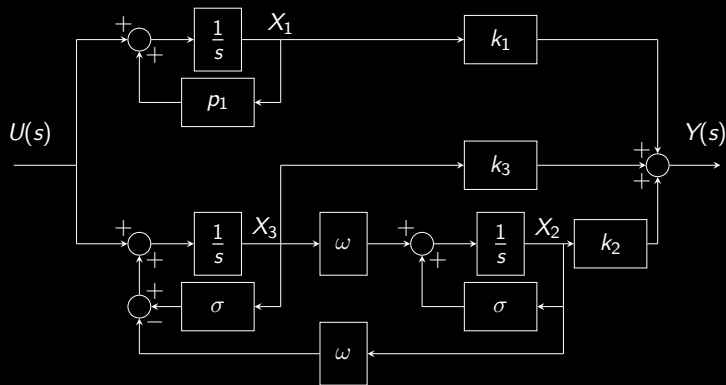

⇒ *modified Jordan form:*

$$A = \begin{bmatrix} p_1 & 0 & 0 \\ 0 & \sigma & \omega \\ 0 & -\omega & \sigma \end{bmatrix}, \quad B = \begin{bmatrix} 1 \\ 0 \\ 1 \end{bmatrix}, \quad C = [k_1 \quad k_2 \quad k_3], \quad D = 0$$

Continuous- and discrete-time state-space descriptions

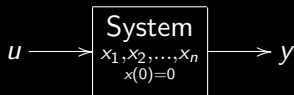

$$\dot{x}(t) = Ax(t) + Bu(t)$$

$$y(t) = Cx(t) + Du(t)$$

$$sX(s) = AX(s) + BU(s)$$

$$Y(s) = CX(s) + DU(s)$$

$$x(k+1) = Ax(k) + Bu(k)$$

$$y(k) = Cx(k) + Du(k)$$

$$zX(z) = AX(z) + BU(z)$$

$$Y(z) = CX(z) + DU(z)$$

- ▶ previous procedure applies to discrete-time systems
- ▶ replace t with k , and $\dot{x}(t)$ with $x(k+1)$
- ▶ replace s with z , and $\boxed{\frac{1}{s}}$ with $\boxed{z^{-1}}$ in block diagrams

DT controllable canonical form

$$G(z) = \frac{b_2 z^2 + b_1 z + b_0}{z^3 + a_2 z^2 + a_1 z + a_0}$$

- ▶ same transfer-function structure
- ▶ \Rightarrow same A , B , C , D matrices as those in CT
- ▶ controllable canonical form:

$$\begin{bmatrix} x_1(k+1) \\ x_2(k+1) \\ x_3(k+1) \end{bmatrix} = \begin{bmatrix} 0 & 1 & 0 \\ 0 & 0 & 1 \\ -a_0 & -a_1 & -a_2 \end{bmatrix} \begin{bmatrix} x_1(k) \\ x_2(k) \\ x_3(k) \end{bmatrix} + \begin{bmatrix} 0 \\ 0 \\ 1 \end{bmatrix} u(k)$$

$$y(k) = \begin{bmatrix} b_0 & b_1 & b_2 \end{bmatrix} \begin{bmatrix} x_1(k) \\ x_2(k) \\ x_3(k) \end{bmatrix}$$

DT controllable canonical form

$$G(z) = \frac{b_2 z^2 + b_1 z + b_0}{z^3 + a_2 z^2 + a_1 z + a_0}$$

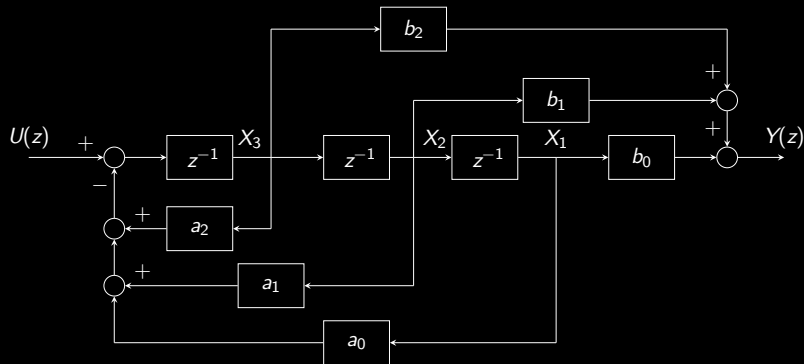

DT observable canonical form

$$G(z) = \frac{b_2 z^2 + b_1 z + b_0}{z^3 + a_2 z^2 + a_1 z + a_0}$$

► observable canonical form:

$$\begin{bmatrix} x_1(k+1) \\ x_2(k+1) \\ x_3(k+1) \end{bmatrix} = \begin{bmatrix} -a_2 & 1 & 0 \\ -a_1 & 0 & 1 \\ -a_0 & 0 & 0 \end{bmatrix} \begin{bmatrix} x_1(k) \\ x_2(k) \\ x_3(k) \end{bmatrix} + \begin{bmatrix} b_2 \\ b_1 \\ b_0 \end{bmatrix} u(k)$$

$$y(k) = \begin{bmatrix} 1 & 0 & 0 \end{bmatrix} \begin{bmatrix} x_1(k) \\ x_2(k) \\ x_3(k) \end{bmatrix}$$

DT diagonal form

$$G(z) = \frac{b_2 z^2 + b_1 z + b_0}{z^3 + a_2 z^2 + a_1 z + a_0}$$

► diagonal form (distinct poles):

$$G(z) = \frac{k_1}{z - p_1} + \frac{k_2}{z - p_2} + \frac{k_3}{z - p_3}$$

$$\begin{bmatrix} x_1(k+1) \\ x_2(k+1) \\ x_3(k+1) \end{bmatrix} = \begin{bmatrix} p_1 & 0 & 0 \\ 0 & p_2 & 0 \\ 0 & 0 & p_3 \end{bmatrix} \begin{bmatrix} x_1(k) \\ x_2(k) \\ x_3(k) \end{bmatrix} + \begin{bmatrix} 1 \\ 1 \\ 1 \end{bmatrix} u(k)$$

$$y(k) = \begin{bmatrix} k_1 & k_2 & k_3 \end{bmatrix} \begin{bmatrix} x_1(k) \\ x_2(k) \\ x_3(k) \end{bmatrix}$$

DT Jordan form 1

$$G(z) = \frac{b_2 z^2 + b_1 z + b_0}{z^3 + a_2 z^2 + a_1 z + a_0}$$

► Jordan form (2 repeated poles):

$$G(z) = \frac{k_1}{z - p_1} + \frac{k_2}{(z - p_m)^2} + \frac{k_3}{z - p_m}$$

$$\begin{bmatrix} x_1(k+1) \\ x_2(k+1) \\ x_3(k+1) \end{bmatrix} = \begin{bmatrix} p_1 & 0 & 0 \\ 0 & p_m & 1 \\ 0 & 0 & p_m \end{bmatrix} \begin{bmatrix} x_1(k) \\ x_2(k) \\ x_3(k) \end{bmatrix} + \begin{bmatrix} 1 \\ 0 \\ 1 \end{bmatrix} u(k)$$

$$y(k) = \begin{bmatrix} k_1 & k_2 & k_3 \end{bmatrix} \begin{bmatrix} x_1(k) \\ x_2(k) \\ x_3(k) \end{bmatrix}$$

DT Jordan form 2

$$G(z) = \frac{b_2 z^2 + b_1 z + b_0}{z^3 + a_2 z^2 + a_1 z + a_0}$$

► Jordan form (2 complex poles):

$$G(s) = \frac{k_1}{z - p_1} + \frac{\alpha z + \beta}{(z - \sigma)^2 + \omega^2}$$

$$\begin{bmatrix} x_1(k+1) \\ x_2(k+1) \\ x_3(k+1) \end{bmatrix} = \begin{bmatrix} p_1 & 0 & 0 \\ 0 & \sigma & \omega \\ 0 & -\omega & \sigma \end{bmatrix} \begin{bmatrix} x_1(k) \\ x_2(k) \\ x_3(k) \end{bmatrix} + \begin{bmatrix} 1 \\ 0 \\ 1 \end{bmatrix} u(k)$$

$$y(k) = \begin{bmatrix} k_1 & k_2 & k_3 \end{bmatrix} \begin{bmatrix} x_1(k) \\ x_2(k) \\ x_3(k) \end{bmatrix}$$

where $k_2 = (\beta + \alpha\sigma)/\omega$, $k_3 = \alpha$.

Exercise

obtain the controllable canonical form:

$$\blacktriangleright G(s) = \frac{z^{-1} - z^{-3}}{1 + 2z^{-1} + z^{-2}}$$

Relation between different realizations

- ▶ given one realization Σ and a nonsingular $T \in \mathbb{R}^{n \times n}$
- ▶ can define *new* states: $Tx^* = x$
- ▶ then

$$\dot{x}(t) = Ax(t) + Bu(t) \Rightarrow \frac{d}{dt} (Tx^*(t)) = ATx^*(t) + Bu(t),$$

$$\Rightarrow \Sigma^* : \begin{cases} \dot{x}^*(t) &= T^{-1}ATx^*(t) + T^{-1}Bu(t) \\ y(t) &= CTx^*(t) + Du(t) \end{cases}$$

- ▶ namely

$$\Sigma^* = \left[\begin{array}{c|c} T^{-1}AT & T^{-1}B \\ \hline CT & D \end{array} \right]$$

also realizes $G(s)$ and is said to be *similar* to Σ

Relation between different realizations

verify that the following realize the same system

$$\Sigma = \left[\begin{array}{ccc|c} -a_2 & 1 & 0 & b_2 \\ -a_1 & 0 & 1 & b_1 \\ -a_0 & 0 & 0 & b_0 \\ \hline 1 & 0 & 0 & d \end{array} \right], \quad \Sigma^* = \left[\begin{array}{ccc|c} 0 & 0 & -a_0 & b_0 \\ 1 & 0 & -a_1 & b_1 \\ 0 & 1 & -a_2 & b_2 \\ \hline 0 & 0 & 1 & d \end{array} \right]$$