

## ON THE RELATIONSHIP BETWEEN MINIMAL LATTICE KNOTS AND MINIMAL CUBE KNOTS

CASEY MANN AND JENNIFER MCLOUD-MANN

*The University of Texas at Tyler*  
3900 University Blvd, Department of Mathematics, HPR 102, Tyler, TX 75799

Received (Leave 1 inch blank space for publisher.)

Revised

### ABSTRACT

Lattice knots have been studied in recent years, especially in  $\mathbb{Z}^3$  and with respect to how many edges are required to form a knot. Knots formed from cubes have also been investigated for their ability to tessellate space. In this article, we demonstrate that there is a relationship between the minimum number of edges required to form a lattice knot and the minimum number of cubes required to form the same kind of knot. We further investigate the relationship in the face-centered cubic lattice.

### 1. Introduction

The *cubic lattice* is the point set  $\mathbb{Z}^3 = \{(x, y, z) \mid x, y, z \in \mathbb{Z}\}$ . We define *steps* in  $\mathbb{Z}^3$  to be unit segments with endpoints in  $\mathbb{Z}^3$ . A  $\mathbb{Z}^3$ -*lattice knot* of type  $K$  is a simple closed polygonal cycle of steps in  $\mathbb{Z}^3$  that forms a knot of type  $K$ . For each knot type  $K$ , there is a minimum number of steps required to form a  $\mathbb{Z}^3$ -lattice knot of type  $K$ ; we call this number the  $\mathbb{Z}^3$ -*minimal step number* of knot type  $K$ .<sup>a</sup> Surprisingly, not much is known about minimal step numbers. In [1], Diao showed that the trefoil knot has  $\mathbb{Z}^3$ -minimal step number 24, and it is conjectured in [2] that the figure eight knot has  $\mathbb{Z}^3$ -minimal step number 30. Figure 1 shows a  $\mathbb{Z}^3$ -minimal cubic lattice trefoil knot formed from 24 steps.

We will also discuss lattice knots in other lattices. Let  $\mathcal{L}$  be a three-dimensional lattice. Some care must be taken in defining  $\mathcal{L}$ -steps; rather than introducing too much terminology here, let us just state that there is a notion of points in  $\mathcal{L}$  being *adjacent*.  $\mathcal{L}$ -steps are then just segments whose endpoints are adjacent points of  $\mathcal{L}$ .  $\mathcal{L}$ -lattice knots and  $\mathcal{L}$ -minimal step numbers of knot type  $K$  are defined analogously to the  $\mathbb{Z}^3$  case. Even less is known about minimal step numbers if we look at other lattices; the only work known to the authors is in [3], where it is conjectured that the

---

<sup>a</sup>The terminology for the minimal step number of a knot type varies in the literature; it is sometimes called the *lattice number* of a knot type, or the *minimal edge number* of a knot type. We propose the new term *minimal step number* to avoid confusion over the term “edge” which appears in multiple contexts.

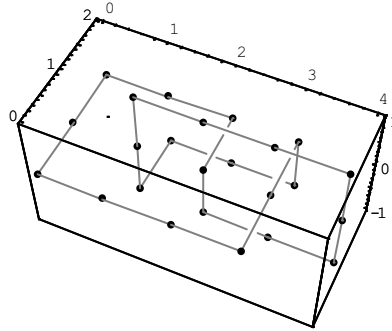

Fig. 1. A minimal trefoil knot in the cubic lattice.

trefoil knot has minimal step number 16 in the face-centered cubic lattice. Figure 2 shows such trefoil made from 16 steps [4].

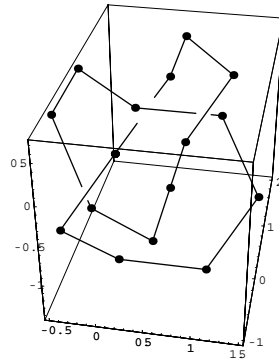

Fig. 2. A trefoil knot in the face-centered cubic lattice of step size 16

The main result of this paper concerns the relationship between  $\mathbb{Z}^3$ -lattice knots and objects we call *cube knots*. The cubes used to form these cube knots are unit cubes whose centers lie in the cubic lattice and whose faces are parallel to the coordinate planes. Let us call such cubes *lattice cubes*. A *cube knot* of type  $K$  is then a connected cycle of lattice cubes  $\{C_1, C_2, \dots, C_n\}$  such that

1. consecutive  $C_i$  meet face-to-face,
2. centers of consecutive  $C_i$ , when pairwise joined together by steps, form a  $\mathbb{Z}^3$ -lattice knot of type  $K$  (called the *core knot*), and
3. distinct bars (that is, straight sequences of cubes) intersect if and only if they are consecutive.

In essence, a cube knot of type  $K$  is defined to be a cycle of cubes that has a  $\mathbb{Z}^3$ -lattice knot of type  $K$  at its core and in which consecutive “bars” of cubes may only intersect at a common corner cube. Nonconsecutive bars may not intersect at all. Figure 3 shows a well-formed cube knot.

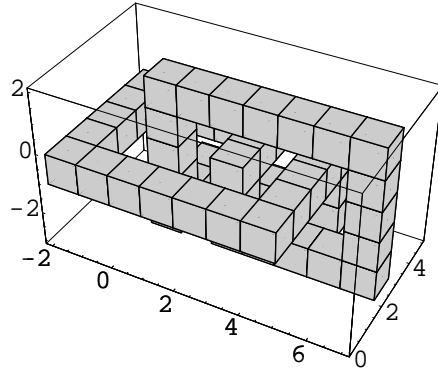

Fig. 3. A cube trefoil knot

For each knot type  $K$ , there is a minimum number of cubes required to form a cube knot of type  $K$ ; let this number be called the *minimal cube number* for knot type  $K$ . The main result of this paper points out that there is a relationship between the  $\mathbb{Z}^3$ -minimal step number and the minimal cube number for knot type  $K$ , which is that *for any knot type  $K$ , the minimal cube number is twice the  $\mathbb{Z}^3$ -minimal step number*.

Cube knots have been studied in recent papers. Adams discovered a way to form a trefoil knot that tessellates a larger cube with four-fold symmetry [5]. In particular, Adams posed a question asking about the minimal size cube that may be decomposed into exactly four intertwined trefoil cube knots. In trying to answer this question, one wonders how many cubes are required to build a trefoil knot. Additional work related to cube knots was done in [6].

Later in this paper, other lattices are considered, such as the face-centered cubic lattice, and associated solids which may be formed into knots, such as the rhombic dodecahedron. We conclude the paper with some open problems.

## 2. Definitions

The  $\mathbb{Z}^3$ -minimal step number of a knot type  $K$  will be denoted by  $m_K$  and the minimal cube number will be denoted by  $M_K$ .

**Definition 1.** Let  $D$  be a cube knot. For each integer  $i$ , consider the cubes of  $D$  whose centers have  $z$ -coordinate  $i$ . In each of these collections of cubes, there may be several connected components with volume greater than 1. We call these

components with volume greater than 1 the  $z_i$ -components of  $D$ . Generically, we'll refer to these components as *slab components*. Similarly we define the  $x_i$ - and  $y_i$ -components.

Intuitively, the  $z_i$ -components of  $D$  are the pieces of  $D$  at height  $i$  that “meander” in horizontal slabs at height  $i$ . The components of volume 1 come from vertical bars of the cube knot that are just passing through the slab.

### 3. Main Result

**Theorem 1.** For any knot type  $K$ , the minimal cube number is twice the  $\mathbb{Z}^3$ -minimal step number. That is,  $M_K = 2 \cdot m_K$ .

*Proof.* It is easy to prove that  $M_K \leq 2 \cdot m_K$ . Starting with a minimal lattice knot of type  $K$  with length  $m_K$ , we can scale this knot by a factor of 2 to construct a cube knot  $C$  of type  $K$  whose volume is  $2 \cdot m_K$  in the following way. First, in scaling the lattice knot by a factor of 2, we introduce  $m_K$  additional vertices between the existing vertices. To construct the corresponding cube knot, we place lattice cubes with their centers at the vertices of the scaled lattice knot. The scaled lattice knot will then be at the core of the cube knot. The cube knot formed in the process is well formed, since distinct and nonconsecutive straight sequences of steps in the original lattice knot must have been separated from each other by at least one step, and hence nonconsecutive bars in the cube knot do not intersect. As an example, it is known that  $m_K = 24$  if  $K$  is the trefoil knot [1]. In Figure 4 we see a minimal trefoil knot in the cubic lattice along with its scaled-up cube knot that consists of 48 cubes.

Since we can always form a cube knot  $C$  of type  $K$  of volume  $2 \cdot m_K$  in this way, we know then that  $M_K \leq 2 \cdot m_K$ . In general, we don't know at this point that  $C$  is of minimal volume for knot type  $K$ ; but in fact, as we will prove next,  $C$  is always of minimal volume.

To prove that  $M_K \geq 2 \cdot m_K$ , let  $D$  be an arbitrary cube knot of type  $K$ . An outline of our proof is as follows:

1. Arrange  $D$ , without changing its knot type or increasing its volume, in such a way that the end cubes of every slab component (that is, the corner cubes) have centers on the even integer lattice.
2. Scale the core lattice knot of this rearranged version of  $D$  by  $1/2$  to get a lattice knot whose length is less than or equal to  $1/2$  of the volume of  $D$ .
3. Observe that if  $D$  is of volume less than  $2 \cdot m_K$ , then we would get a lattice knot of length less than  $m_K$ , which is impossible.
4. Therefore, if any cube knot  $D$  can be arranged as described in step 1, we would then know that  $M_K \geq 2 \cdot m_K$ , which would complete our proof.

It remains to be shown that any cube knot  $D$  can be arranged in the aforementioned manner.

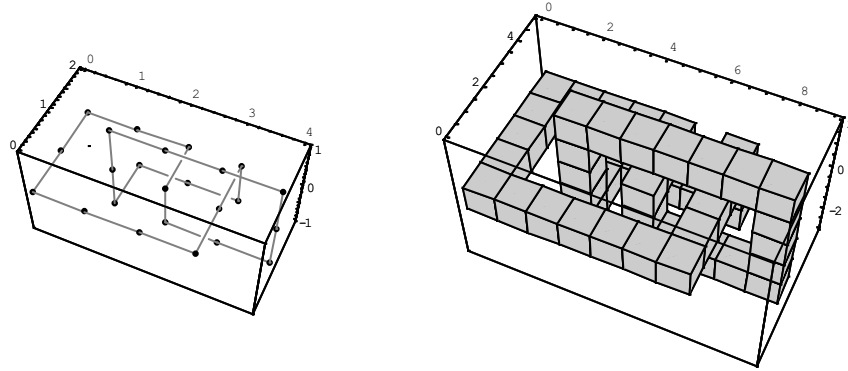

Fig. 4. At left is a minimal trefoil knot in the cubic lattice. At right is the cube knot whose core is the same trefoil knot scaled by 2.

Our first task is to describe certain moves that one can perform on the cube knot without altering the knot type or creating a cube knot that is not well formed. To do this, let us focus for a moment on individual  $z_i$ -components of  $D$ . There are three basic types of  $z_i$ -components with regard to the ends of these components:

- Type I:** both ends of the component connect upward to the other parts of the knot.
- Type II:** both ends of the component connect downward to the other parts of the knot.
- Type III:** one end of the component connects upward and the other connects downward.

In the figures that follow, we describe moves that will be performed on slab components for each of these types and make some observations about them. We describe only upward moves below; the downward moves are similar.

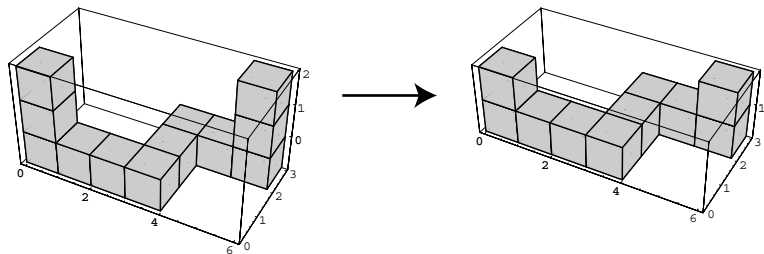

Fig. 5. A Type I component moved upward. Note that this move decreases the volume of a cube knot. Moving a Type I component downward would increase the volume.

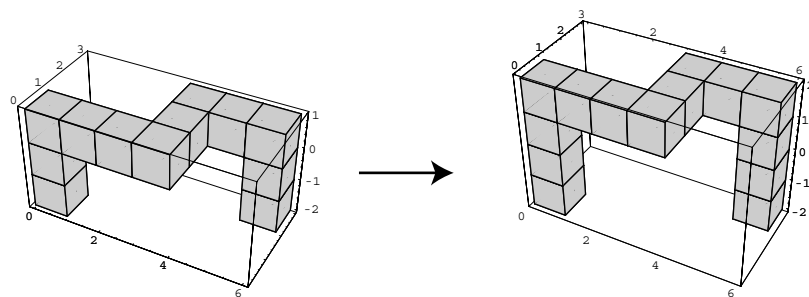

Fig. 6. A Type II component moved upward. Note that this move increases the volume of a cube knot, and a similar downward movement would decrease the volume.

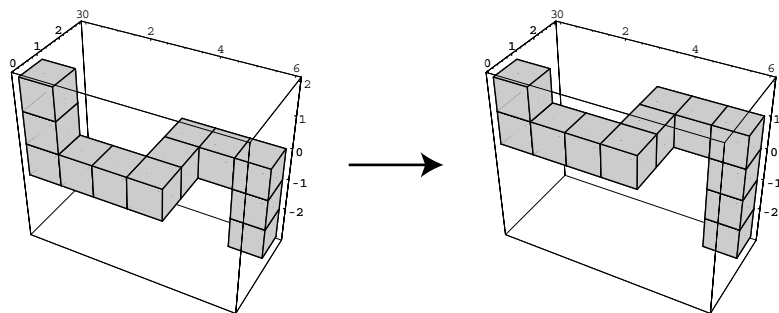

Fig. 7. A Type III component moved upward. Note that this move does not change the volume of a cube knot and neither does a downward movement.

In Figure 8, we give an example that illustrates how the previously described moves are used to arrange a cube knot, without changing its knot type or increasing its volume, so that its corner cubes' centers are on the even integer lattice.

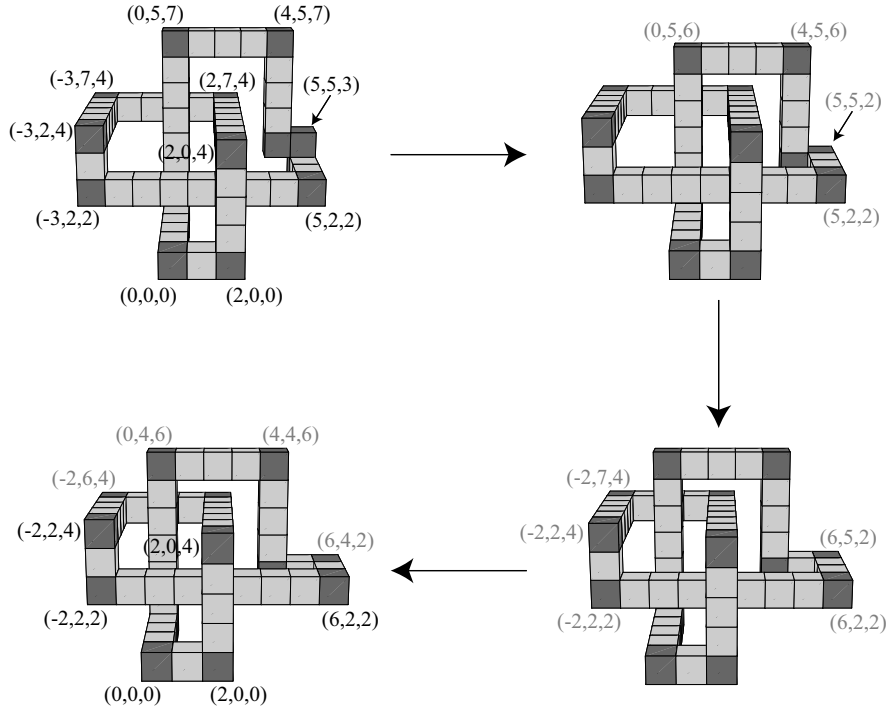

Fig. 8. A sequence of moves applied to a cube knot. From upper left, clockwise: A cube knot, the knot with moves applied parallel to the  $z$ -axis, the knot with moves applied parallel to the  $x$ -axis, and the knot with moves applied parallel to the  $y$ -axis.

Now let us make various observations about these local slab component moves. For simplicity, let  $S_1$  be a  $z_1$ -component. Moving  $S_1$  upward can result in a new  $z_2$ -component or it may join with an existing  $z_2$ -component to form an even longer  $z_2$ -component. Either way, call this new  $z_2$ -component  $S_2$ . Observe that in the former case,  $S_1$  does not intersect or abut any existing  $z_2$ -component, for if  $S_1$  abutted with another  $z_2$ -component  $S'$ , then there would exist a cube in  $S_1$  and a cube in  $S'$  that intersect along their boundaries, meaning the cube knot was not well formed in the first place. Notice that there can be abutting that occurs between a new  $z_2$ -component and an existing  $z_3$ -component. To resolve this we move all odd slab components upward simultaneously. This will ensure in the above situation that there are no nontrivial  $z_3$ -components after shifting upward and thus the abutting problem cannot occur. At this point we have successfully arranged the cube knot without changing the knot type so that the end cubes of every slab component

have centers where all  $z$ -coordinates are even and other coordinates are unchanged. Make note that we could make this arrangement with downward movements too. Now it is time to see that we can make this arrangement without increasing the volume of the cube knot.

Moving a slab component of type I upward decreases the volume of the cube knot by 2, and moving it down increases the volume by 2. Similarly for type II slab components. Moving a slab component of type III either upward or downward does not change the volume of the cube knot. Let  $N_I$  denote the number of *odd* slab components of type I and  $N_{II}$  the number of *odd* slab components of type II. Moving *every* odd slab component up one unit results in a volume change of  $-2N_I + 2N_{II}$  while moving *every* odd slab component down one unit results in a volume change of  $2N_I - 2N_{II}$ . Either an upward or downward move will result in a volume change less than or equal to zero. Thus we can successfully arrange the cube knot without changing the knot type so that the end cubes of every slab component have centers where all  $z$ -coordinates are even and other coordinates are unchanged *and* without increasing the volume of the cube knot as desired in our aforementioned goal.

If this process is repeated for the other two coordinate directions, the result is a cube knot  $D'$  that satisfies the following:

- The knot type of  $D'$  is the same as the knot type of  $D$ , since at no step did the knot self-intersect.
- The volume of  $D'$  is less than or equal to the volume of the original cube knot  $D$ .
- The points at the centers of the cubes at the ends of all slab components are on the even integer lattice.

This then completes the proof.  $\square$

#### 4. Generalizations and Open Problems

It is natural to wonder if analogous results to our main theorem hold for other lattices. The generalized version of our problem would be based on knots in general lattices and the corresponding knots that can be formed from the Voronoï cells of the lattice [7]. A *point lattice* generated by a linearly independent set of vectors  $\{v_1, v_2, v_3\} \subset \mathbb{R}^3$  is the set of points  $\mathcal{L} = \{\sum a_i v_i \mid a_i \in \mathbb{Z}\}$ . Then, given a lattice  $\mathcal{L}$ , we define the *Voronoï cell* of a point  $p \in \mathcal{L}$  to be the set of points of  $\mathbb{R}^3$  that lie at least as close to  $p$  as to any other points of  $\mathcal{L}$ ; that is, the Voronoï cell of  $p \in \mathcal{L}$  is

$$V(p) = \{x \in \mathbb{R}^n \mid |p - x| \leq |q - x| \text{ for all } q \in \mathcal{L}\}.$$

For each lattice, the corresponding Voronoï cells are all congruent and tessellate  $\mathbb{R}^3$  meeting face-to-face and vertex-to-vertex. For example, the cubic lattice  $\mathbb{Z}^3$  has unit cubes as Voronoï cells, and these cubes tessellate  $\mathbb{R}^3$ . Another example is the face-centered cubic lattice, which is generated by the vectors  $(1, 0, 0)$ ,  $(0, 1, 0)$ ,



and  $(\frac{1}{2}, \frac{1}{2}, \frac{1}{\sqrt{2}})$ . The Voronoi cell of this lattice is the rhombic dodecahedron, and again, these solids tessellate  $\mathbb{R}^3$ . As it turns out, Fedorov [8] gave a classification of all possible Voronoi cells, and there are only five combinatorial types (the so-called *parallelohedra*); they are the cube, hexagonal prism, rhombic dodecahedron, hexarhombic dodecahedron, and truncated octahedron.

**Open Question 1.** For a given lattice  $\mathcal{L}$  and nontrivial knot type  $K$ , let  $m_K$  be the minimum number of  $\mathcal{L}$ -steps required to form a knot of type  $K$ , and let  $M_K$  be the minimum number of Voronoi cells of  $\mathcal{L}$  needed to form a knot of the same type. For every lattice  $\mathcal{L}$ , does there exist a real number  $C_{\mathcal{L}}$  such that  $M_K = C_{\mathcal{L}} \cdot m_K$ ?

The authors have experimented with forming knots made from rhombic dodecahedra. We conjecture that a trefoil knot formed from rhombic dodecahedra requires a minimum of 40 cells (Figure 9), and a figure eight knot requires a minimum of 50 rhombic dodecahedra (Figure 10).

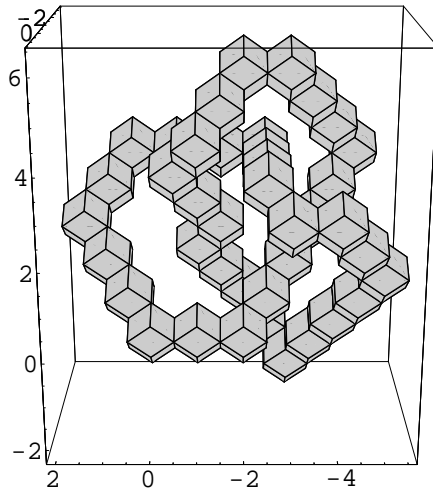

Fig. 9. A well-formed trefoil knot formed from 40 rhombic dodecahedra.

The core knots of these rhombic dodecahedra are not minimal when scaled by  $1/2$ , for examples of trefoil lattice knots in the face-centered of step size 16 have been found (the conjectured minimum [3]) and examples of figure eight lattice knots of step size 20 have been found (we conjecture this is minimal as well). Thus it seems that  $C_{\mathcal{L}} \neq 2$  in the face centered cubic lattice. To illustrate this, we have formed a trefoil made from 16 steps in the face-centered cubic lattice, scaled this knot by a factor of 2, and tried to use this scaled knot as the core knot of a rhombic dodecahedron knot. This did not yield a well-formed knot, as it self-intersected at vertices of nonconsecutive bars (Figure 11).

Based on these examples, we offer the following conjecture:

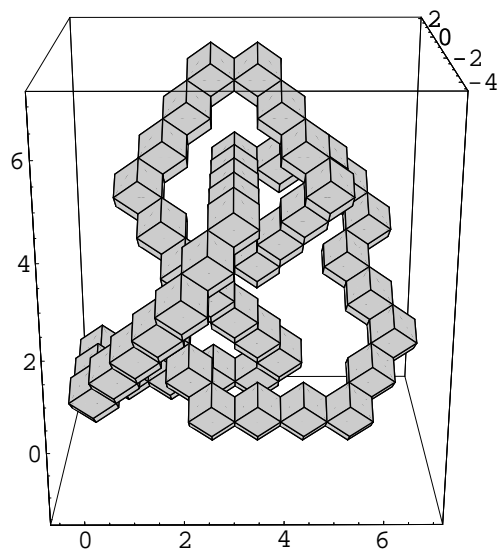

Fig. 10. A well-formed figure eight knot formed from 50 rhombic dodecahedra.

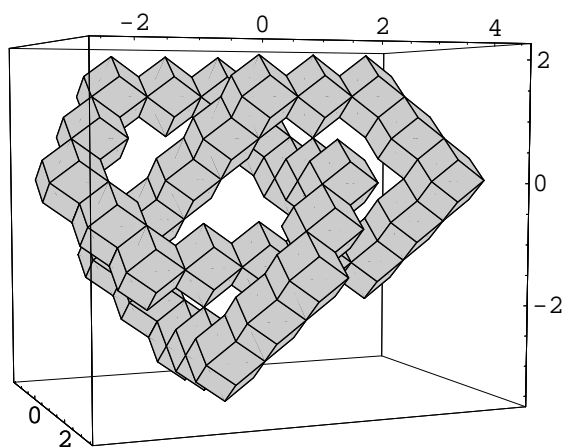

Fig. 11. A trefoil knot formed from 32 rhombic dodecahedra that is not well formed. The knot self-intersects at vertices.

**Conjecture 1.** For the face centered cubic lattice,  $M_K = \lceil 2.5 \cdot m_K \rceil$ .

If we consider lattice knots alone, not much is known, even in  $\mathbb{Z}^3$ , much less knots in other lattices. For example the following problems are open.

**Open Question 2.** What is the minimal step number of the figure eight knot in  $\mathbb{Z}^3$  and in the face-centered cubic lattice?

It is conjectured that the  $\mathbb{Z}^3$ -minimal step number of the figure eight knot is 30 [2]. We conjecture that the minimal step number is 20 in the face-centered cubic lattice.

**Open Question 3.** For lattices corresponding to the hexagonal prism, rhombic dodecahedron, hexarhombic dodecahedron, and truncated octahedron, what is the minimal step number of the trefoil knot?

### Acknowledgements

The authors would like thank Colin Adams for all of his help and useful suggestions. This work was partially funded by the Faculty Research Grant at the University of Texas at Tyler for both authors.

- [1] Y. Diao, *Minimal Knotted Polygons on the Cubic Lattice*, J. of Knot Theory and its Ramifications **2** (1993) 413–425.
- [2] E. J. Janse van Rensburg, *Minimal Knots in the Cubic Lattice*, J. of Knot Theory and its Ramifications **4** (1995) 115–130.
- [3] E.J. Janse van Rensburg and S.G. Whittington, *The Knot Probability in Lattice Polygons*, J. Phys. A: Math. and Gen. **23** (1990) 3573–3590.
- [4] E.J. Janse van Rensburg, *Minimal Lattice Knots*, Ideal Knots, 88–106, Ser. Knots Everything **19**, World Sci. Publishing, River Edge, NJ (1998).
- [5] C. Adams, *Tiling Three-Space with Knotted Tiles*, The Mathematical Intelligencer, **17** No. 2 (1995) 41–51.
- [6] S. Oh, *Knotted Solid Tori Decompositions of  $B^3$  and  $S^3$* , Journal of Knot Theory and Its Ramifications, **5** No. 3 (1996) 405–416.
- [7] M. Senechal, *Quasicrystals and geometry*, Cambridge University Press, New York (1995).
- [8] E.S. Fedorov, *Nachala Ucheniya o Figurakh*, Notices of the Imperial St. Petersburg Mineralogical Society, 2nd series, Vol. 21, 1–279.