

TCSS 462/562: (SOFTWARE ENGINEERING FOR) CLOUD COMPUTING

Introduction to Cloud Computing

Wes J. Lloyd
School of Engineering and Technology
University of Washington - Tacoma
TR 5:50-7:50 PM



1

OBJECTIVES - 10/12

- **Questions from 10/10**
- Properties of Distributed Systems, Modularity
- Introduction to Cloud Computing –based on book #1:
Cloud Computing Concepts, Technology & Architecture
 - Why study cloud computing?
 - History of cloud computing
 - Business drivers
 - Cloud enabling technologies
 - Terminology
 - Benefits of cloud adoption
 - Risks of cloud adoption
- Background on AWS Lambda for the Term Project

October 12, 2023	TCSS462/562:(Software Engineering for) Cloud Computing [Fall 2023] School of Engineering and Technology, University of Washington - Tacoma	L5.2
------------------	---	------

2

OFFICE HOURS – FALL 2023

- **Tuesdays:**
 - 2:30 to 3:30 pm - CP 229 and Zoom
- **Fridays**
 - 11:00 am to 12:00 pm – ONLINE via Zoom*
- Or email for appointment

➤ Office Hours set based on Student Demographics survey feedback

➤ * - Periodically friday office hours may need to be adjusted due to conflicts with faculty meetings. I will also review turnout, and consider adjusting the time on Fridays if turnout is low.

October 12, 2023	TCSS462/562:(Software Engineering for) Cloud Computing [Fall 2023] School of Engineering and Technology, University of Washington - Tacoma	L5.3
------------------	---	------

3

ONLINE DAILY FEEDBACK SURVEY

- Daily Feedback Quiz in Canvas – Take After Each Class
- Extra Credit for completing

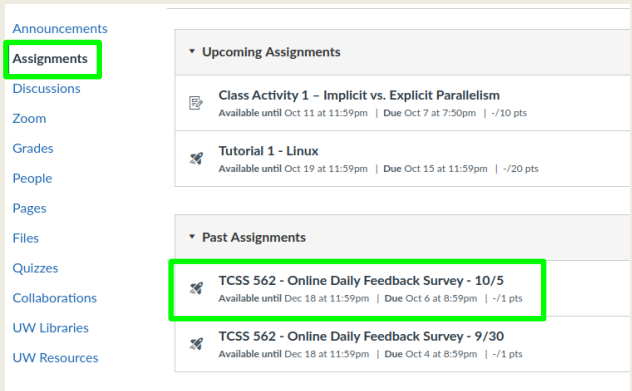

October 12, 2023	TCSS462/562:(Software Engineering for) Cloud Computing [Fall 2023] School of Engineering and Technology, University of Washington - Tacoma	L5.4
------------------	---	------

4

TCSS 562 - Online Daily Feedback Survey - 10/5
Started: Oct 7 at 1:13am
Quiz Instructions

Question 1 0.5 pts

On a scale of 1 to 10, please classify your perspective on material covered in today's class:

1 2 3 4 5 6 7 8 9 10
Mostly Review To Me Equal New and Review Mostly New to Me

Question 2 0.5 pts

Please rate the pace of today's class:

1 2 3 4 5 6 7 8 9 10
Slow Just Right Fast

October 12, 2023 TCSS462/562:(Software Engineering for) Cloud Computing [Fall 2023] School of Engineering and Technology, University of Washington - Tacoma L5.5

5

MATERIAL / PACE

- Please classify your perspective on material covered in today's class (58 respondents):
 - 1-mostly review, 5-equal new/review, 10-mostly new
 - **Average - 6.53 (↓ - previous 6.80)**
- Please rate the pace of today's class:
 - 1-slow, 5-just right, 10-fast
 - **Average - 5.55 (↓ - previous 5.64)**
- **Response rates:**
 - TCSS 462: 38/45 - 84.4%
 - TCSS 562: 20/24 - 83.3%

October 12, 2023 TCSS462/562:(Software Engineering for) Cloud Computing [Fall 2023] School of Engineering and Technology, University of Washington - Tacoma L5.6

6

FEEDBACK FROM 10/10

■ ..

October 12, 2023	TCSS462/562:(Software Engineering for) Cloud Computing [Fall 2023] School of Engineering and Technology, University of Washington - Tacoma	L5.7
------------------	---	------

7

AWS CLOUD CREDITS UPDATE

- Our AWS cloud credit request was submitted Thursday, Oct 5th, and we received acknowledgement Monday afternoon Oct 9th that the request has been submitted to the higher-ups.
- We hope that cloud credits will be available soon
- Once available, the credit codes must be securely exchanged
 - This can be in person (or by zoom), in the class, during the breaks, after class, or during office hours
 - Credits can also be requested by email by sending an email with the subject **"AWS CREDIT REQUEST"** to wlloyd@uw.edu
 - Please use this exact subject so the email is not missed
 - 12 requests are presently queued
 - To track credit code distribution, codes will not be shared via discord

October 10, 2023	TCSS462/562: (Software Engineering for) Cloud Computing [Fall 2023] School of Engineering and Technology, University of Washington - Tacoma	L4.8
------------------	--	------

8

TUTORIAL 0

- Getting Started with AWS
- http://faculty.washington.edu/wlloyd/courses/tcss562/tutorials/TCSS462_562_f2023_tutorial_0.pdf
- Create an AWS account
- Create account credentials for working with the CLI
- Install awsconfig package
- Setup awsconfig for working with the AWS CLI

October 12, 2023

TCSS462/562:(Software Engineering for) Cloud Computing [Fall 2023]
School of Engineering and Technology, University of Washington - Tacoma

L5.9

9

TUTORIAL 1

- **Introduction to Linux & the Command Line**
- https://faculty.washington.edu/wlloyd/courses/tcss562/tutorials/TCSS462_562_f2023_tutorial_1.pdf
- **Tutorial Sections:**
 1. The Command Line
 2. Basic Navigation
 3. More About Files
 4. Manual Pages
 5. File Manipulation
 6. VI - Text Editor
 7. Wildcards
 8. Permissions
 9. Filters
 10. Grep and regular expressions
 11. Piping and Redirection
 12. Process Management

October 11, 2022

TCSS462/562:(Software Engineering for) Cloud Computing [Fall 2023]
School of Engineering and Technology, University of Washington - Tacoma

L4.10

10

TUTORIAL 2

- **Introduction to Bash Scripting**
- https://faculty.washington.edu/wlloyd/courses/tcss562/tutorials/TCSS462_562_f2023_tutorial_2.pdf
- Review tutorial sections:
- Create a BASH webservice client
 1. What is a BASH script?
 2. Variables
 3. Input
 4. Arithmetic
 5. If Statements
 6. Loops
 7. Functions
 8. User Interface
- Call service to obtain IP address & lat/long of computer
- Call weatherbit.io API to obtain weather forecast for lat/long

October 11, 2022

TCSS462/562:(Software Engineering for) Cloud Computing [Fall 2023]
School of Engineering and Technology, University of Washington - Tacoma

L4.11

11

TUTORIAL 3

- **Best Practices for Working with Virtual Machines on Amazon EC2**
- http://faculty.washington.edu/wlloyd/courses/tcss562/tutorials/TCSS462_562_f2023_tutorial_3.pdf
- Creating a spot VM
- Creating an image from a running VM
- Persistent spot request
- Stopping (pausing) VMs
- EBS volume types
- Ephemeral disks (local disks)
- Mounting and formatting a disk
- Disk performance testing with Bonnie++
- Cost Saving Best Practices

October 12, 2023

TCSS462/562:(Software Engineering for) Cloud Computing [Fall 2023]
School of Engineering and Technology, University of Washington - Tacoma

L5.12

12

OBJECTIVES - 10/12

- **Questions from 10/10**
- **Properties of Distributed Systems, Modularity**
- **Introduction to Cloud Computing –based on book #1: Cloud Computing Concepts, Technology & Architecture**
 - Why study cloud computing?
 - History of cloud computing
 - Business drivers
 - Cloud enabling technologies
 - Terminology
 - Benefits of cloud adoption
 - Risks of cloud adoption
- **Background on AWS Lambda for the Term Project**

October 12, 2023	TCSS462/562:(Software Engineering for) Cloud Computing [Fall 2023] School of Engineering and Technology, University of Washington - Tacoma	L5.13
------------------	---	-------

13

DISTRIBUTED SYSTEMS

- Collection of autonomous computers, connected through a network with distribution software called “middleware” that enables coordination of activities and sharing of resources
- **Key characteristics:**
- Users perceive system as a single, integrated computing facility.
- Compute nodes are autonomous
- Scheduling, resource management, and security implemented by every node
- Multiple points of control and failure
- Nodes may not be accessible at all times
- System can be scaled by adding additional nodes
- Availability at low levels of HW/software/network reliability

October 12, 2023	TCSS462/562:(Software Engineering for) Cloud Computing [Fall 2023] School of Engineering and Technology, University of Washington - Tacoma	L5.14
------------------	---	-------

14

DISTRIBUTED SYSTEMS - 2

- Key non-functional attributes
 - Known as “ilities” in software engineering
- Availability – 24/7 access?
- Reliability - Fault tolerance
- Accessibility – reachable?
- Usability – user friendly
- Understandability – can understand
- Scalability – responds to variable demand
- Extensibility – can be easily modified, extended
- Maintainability – can be easily fixed
- Consistency – data is replicated correctly in timely manner

October 12, 2023

TCSS462/562:(Software Engineering for) Cloud Computing [Fall 2023]
School of Engineering and Technology, University of Washington - Tacoma

L5.15

15

TRANSPARENCY PROPERTIES OF DISTRIBUTED SYSTEMS

- **Access transparency:** local and remote objects accessed using identical operations
- **Location transparency:** objects accessed w/o knowledge of their location.
- **Concurrency transparency:** several processes run concurrently using shared objects w/o interference among them
- **Replication transparency:** multiple instances of objects are used to increase reliability
 - *users are unaware if and how the system is replicated*
- **Failure transparency:** concealment of faults
- **Migration transparency:** objects are moved w/o affecting operations performed on them
- **Performance transparency:** system can be reconfigured based on load and quality of service requirements
- **Scaling transparency:** system and applications can scale w/o change in system structure and w/o affecting applications

October 12, 2023

TCSS462/562:(Software Engineering for) Cloud Computing [Fall 2023]
School of Engineering and Technology, University of Washington - Tacoma

L5.16

16

OBJECTIVES - 10/12

- **Questions from 10/10**
- **Properties of Distributed Systems, Modularity**
- **Introduction to Cloud Computing –based on book #1: Cloud Computing Concepts, Technology & Architecture**
 - **Why study cloud computing?**
 - **History of cloud computing**
 - **Business drivers**
 - **Cloud enabling technologies**
 - **Terminology**
 - **Benefits of cloud adoption**
 - **Risks of cloud adoption**
- **Background on AWS Lambda for the Term Project**

October 12, 2023	TCSS462/562:(Software Engineering for) Cloud Computing [Fall 2023] School of Engineering and Technology, University of Washington - Tacoma	L5.17
------------------	---	-------

17

TYPES OF MODULARITY

- **Soft modularity: TRADITIONAL**
 - **Divide a program into modules (classes) that call each other and communicate with shared-memory**
 - **A procedure calling convention is used (or method invocation)**
- **Enforced modularity: CLOUD COMPUTING**
 - **Program is divided into modules that communicate only through message passing**
 - **The ubiquitous client-server paradigm**
 - **Clients and servers are independent decoupled modules**
 - **System is more robust if servers are stateless**
 - **May be scaled and deployed separately**
 - **May also FAIL separately!**

October 12, 2023	TCSS462/562:(Software Engineering for) Cloud Computing [Fall 2023] School of Engineering and Technology, University of Washington - Tacoma	L5.18
------------------	---	-------

18

CLOUD COMPUTING – HOW DID WE GET HERE? SUMMARY OF KEY POINTS

- Multi-core CPU technology and hyper-threading
- What is a
 - Heterogeneous system?
 - Homogeneous system?
 - Autonomous or self-organizing system?
- **Fine grained vs. coarse grained parallelism**
- Parallel message passing code is easier to debug than shared memory (e.g. p-threads)
- Know your application's max/avg **Thread Level Parallelism (TLP)**
- **Data-level parallelism:** Map-Reduce, (SIMD) Single Instruction Multiple Data, Vector processing & GPUs

October 12, 2023	TCSS462/562:(Software Engineering for) Cloud Computing [Fall 2023] School of Engineering and Technology, University of Washington - Tacoma	L5.19
------------------	---	-------

19

CLOUD COMPUTING – HOW DID WE GET HERE? SUMMARY OF KEY POINTS - 2

- **Bit-level parallelism**
- **Instruction-level parallelism** (CPU pipelining)
- **Flynn's taxonomy:** computer system architecture classification
 - **SISD** – Single Instruction, Single Data (modern core of a CPU)
 - **SIMD** – Single Instruction, Multiple Data (Data parallelism)
 - **MIMD** – Multiple Instruction, Multiple Data
 - **MISD** is RARE; application for fault tolerance...
- **Arithmetic intensity:** ratio of calculations vs memory RW
- **Roofline model:**
Memory bottleneck with low arithmetic intensity
- **GPUs:** ideal for programs with high arithmetic intensity
 - SIMD and Vector processing supported by many large registers

October 12, 2023	TCSS462/562:(Software Engineering for) Cloud Computing [Fall 2023] School of Engineering and Technology, University of Washington - Tacoma	L5.20
------------------	---	-------

20

CLOUD COMPUTING - HOW DID WE GET HERE? SUMMARY OF KEY POINTS - 3

- **Speed-up (S)**
 $S(N) = T(1) / T(N)$
- **Amdahl's law:**
 $S = 1 / ((1-f) + f/N)$
f= fraction of work that is parallel (e.g. 0.25)
N= proposed speed up of the parallel part (e.g. 5x)
- **Gustafson's Scaled speedup with N processes:**
 $S(N) = N + (1 - N) \alpha$
N: Number of processors
 α : fraction of program run time which can't be parallelized
- Moore's Law
- Symmetric core, Asymmetric core, Dynamic core CPU
- Distributed Systems Non-function quality attributes
- Distributed Systems - Types of Transparency
- Types of modularity- Soft, Enforced

October 12, 2023	TCSS462/562:(Software Engineering for) Cloud Computing [Fall 2023] School of Engineering and Technology, University of Washington - Tacoma	L5.21
------------------	---	-------

21

INTRODUCTION TO CLOUD COMPUTING



October 12, 2023	TCSS462/562:(Software Engineering for) Cloud Computing [Fall 2023] School of Engineering and Technology, University of Washington - Tacoma	L5.22
------------------	---	-------

22

OBJECTIVES - 10/12

- Questions from 10/10
- Properties of Distributed Systems, Modularity
- Introduction to Cloud Computing –based on book #1:
Cloud Computing Concepts, Technology & Architecture
 - Why study cloud computing?
 - History of cloud computing
 - Business drivers
 - Cloud enabling technologies
 - Terminology
 - Benefits of cloud adoption
 - Risks of cloud adoption
- Background on AWS Lambda for the Term Project

October 12, 2023	TCSS462/562:(Software Engineering for) Cloud Computing [Fall 2023] School of Engineering and Technology, University of Washington - Tacoma	L5.23
------------------	---	-------

23

OBJECTIVES - 10/12

- Questions from 10/10
- Properties of Distributed Systems, Modularity
- Introduction to Cloud Computing –based on book #1:
Cloud Computing Concepts, Technology & Architecture
 - Why study cloud computing?
 - History of cloud computing
 - Business drivers
 - Cloud enabling technologies
 - Terminology
 - Benefits of cloud adoption
 - Risks of cloud adoption
- Background on AWS Lambda for the Term Project

October 12, 2023	TCSS462/562:(Software Engineering for) Cloud Computing [Fall 2023] School of Engineering and Technology, University of Washington - Tacoma	L5.24
------------------	---	-------

24

WHY STUDY CLOUD COMPUTING?

- **LINKEDIN - TOP IT Skills** from job app data
 - #1 Cloud and Distributed Computing
 - <https://learning.linkedin.com/week-of-learning/top-skills>
 - #2 Statistical Analysis and Data Mining

- **FORBES Survey – 6 Tech Skills That’ll Help You Earn More**
 - #1 Data Science
 - #2 Cloud and Distributed Computing
 - <http://www.forbes.com/sites/laurencebradford/2016/12/19/6-tech-skills-thatll-help-you-earn-more-in-2017/>

October 12, 2023	TCSS462/562:(Software Engineering for) Cloud Computing [Fall 2023] School of Engineering and Technology, University of Washington - Tacoma	L5.25
------------------	---	-------

25

WHY STUDY CLOUD COMPUTING? - 2

- **Computerworld Magazine**

October 12, 2023	TCSS462/562:(Software Engineering for) Cloud Computing [Fall 2023] School of Engineering and Technology, University of Washington - Tacoma	L5.26
------------------	---	-------

26

OBJECTIVES - 10/12

- **Questions from 10/10**
- **Properties of Distributed Systems, Modularity**
- **Introduction to Cloud Computing –based on book #1: Cloud Computing Concepts, Technology & Architecture**
 - **Why study cloud computing?**
 - **History of cloud computing**
 - **Business drivers**
 - **Cloud enabling technologies**
 - **Terminology**
 - **Benefits of cloud adoption**
 - **Risks of cloud adoption**
- **Background on AWS Lambda for the Term Project**

October 12, 2023	TCSS462/562:(Software Engineering for) Cloud Computing [Fall 2023] School of Engineering and Technology, University of Washington - Tacoma	L5.27
------------------	---	-------

27

A BRIEF HISTORY OF CLOUD COMPUTING

- **John McCarthy, 1961**
 - **Turing award winner for contributions to AI**
- **“If computers of the kind I have advocated become the computers of the future, then computing may someday be organized as a public utility just as the telephone system is a public utility... The computer utility could become the basis of a new and important industry...”**



October 12, 2023	TCSS462/562:(Software Engineering for) Cloud Computing [Fall 2023] School of Engineering and Technology, University of Washington - Tacoma	L5.28
------------------	---	-------

28

CLOUD HISTORY - 2

- Internet based computer utilities
- Since the mid-1990s
- Search engines: Yahoo!, Google, Bing
- Email: Hotmail, Gmail

- 2000s
- Social networking platforms: MySpace, Facebook, LinkedIn
- Social media: Twitter, YouTube

- Popularized core concepts
- Formed basis of cloud computing

October 12, 2023	TCSS462/562:(Software Engineering for) Cloud Computing [Fall 2023] School of Engineering and Technology, University of Washington - Tacoma	L5.29
------------------	---	-------

29

CLOUD HISTORY: SERVICES - 1

- Late 1990s – Early Software-as-a-Service (SaaS)
 - Salesforce: Remotely provisioned services for the enterprise

- 2002 -
 - Amazon Web Services (AWS) platform: Enterprise oriented services for remotely provisioned storage, computing resources, and business functionality

- 2006 – **Infrastructure-as-a-Service (IaaS)**
 - Amazon launches Elastic Compute Cloud (EC2) service
 - Organization can “lease” computing capacity and processing power to host enterprise applications
 - Infrastructure

October 12, 2023	TCSS462/562:(Software Engineering for) Cloud Computing [Fall 2023] School of Engineering and Technology, University of Washington - Tacoma	L5.30
------------------	---	-------

30

CLOUD HISTORY: SERVICES - 2

- 2006 - **Software-as-a-Service (SaaS)**
 - Google: Offers Google DOCS, “MS Office” like fully-web based application for online documentation creation and collaboration
- 2009 - **Platform-as-a-Service (PaaS)**
 - Google: Offers Google App Engine, publicly hosted platform for hosting scalable web applications on google-hosted datacenters

October 12, 2023

TCSS462/562:(Software Engineering for) Cloud Computing [Fall 2023]
School of Engineering and Technology, University of Washington - Tacoma

L5.31

31

CLOUD COMPUTING NIST GENERAL DEFINITION

“Cloud computing is a model for enabling convenient, on-demand network access to a shared pool of configurable computing resources (networks, servers, storage, applications and services) that can be rapidly provisioned and reused with minimal management effort or service provider interaction”...



October 12, 2023

TCSS462/562:(Software Engineering for) Cloud Computing [Fall 2023]
School of Engineering and Technology, University of Washington - Tacoma

L5.32

32

MORE CONCISE DEFINITION

“Cloud computing is a specialized form of distributed computing that introduces utilization models for remotely provisioning scalable and measured resources.”

From *Cloud Computing Concepts, Technology, and Architecture*
Z. Mahmood, R. Puttini, Prentice Hall, 5th printing, 2015

October 12, 2023

TCSS462/562:(Software Engineering for) Cloud Computing [Fall 2023]
School of Engineering and Technology, University of Washington - Tacoma

L5.33

33

OBJECTIVES – 10/12

- **Questions from 10/10**
- **Properties of Distributed Systems, Modularity**
- **Introduction to Cloud Computing –based on book #1: Cloud Computing Concepts, Technology & Architecture**
 - **Why study cloud computing?**
 - **History of cloud computing**
 - **Business drivers**
 - **Cloud enabling technologies**
 - **Terminology**
 - **Benefits of cloud adoption**
 - **Risks of cloud adoption**
- **Background on AWS Lambda for the Term Project**

October 12, 2023

TCSS462/562:(Software Engineering for) Cloud Computing [Fall 2023]
School of Engineering and Technology, University of Washington - Tacoma

L5.34

34

BUSINESS DRIVERS FOR CLOUD COMPUTING		
<ul style="list-style-type: none">■ Capacity planning■ Cost reduction■ Operational overhead■ Organizational agility		
October 12, 2023	TCSS462/562:(Software Engineering for) Cloud Computing [Fall 2023] School of Engineering and Technology, University of Washington - Tacoma	L5.35

35

BUSINESS DRIVERS FOR CLOUD COMPUTING		
<ul style="list-style-type: none">■ Capacity planning<ul style="list-style-type: none">■ Process of determining and fulfilling future demand for IT resources■ Capacity vs. demand<ul style="list-style-type: none">■ Discrepancy between capacity of IT resources and actual demand■ Over-provisioning: resource capacity exceeds demand■ Under-provisioning: demand exceeds resource capacity■ Capacity planning aims to minimize the discrepancy of available resources vs. demand		
October 12, 2023	TCSS462/562:(Software Engineering for) Cloud Computing [Fall 2023] School of Engineering and Technology, University of Washington - Tacoma	L5.36

36

THE GLASS IS HALF FULL
OR HALF EMPTY?
NEITHER. IT'S AT 50%
CAPACITY

DIYLOL.COM

Dwight, The Office TV sitcom

October 12, 2023

TCSS462/562:(Software Engineering for) Cloud Computing [Fall 2023]
School of Engineering and Technology, University of Washington - Tacoma

L5.37

37

BUSINESS DRIVERS FOR CLOUD - 2

- Capacity planning
 - Over-provisioning: is costly due to too much infrastructure
 - Under-provisioning: is costly due to potential for business loss from poor quality of service
- Capacity planning strategies
 - Lead strategy: add capacity in anticipation of demand (pre-provisioning)
 - Lag strategy: add capacity when capacity is fully leveraged
 - Match strategy: add capacity in small increments as demand increases
- Load prediction
 - Capacity planning helps anticipate demand fluctuations

October 12, 2023

TCSS462/562:(Software Engineering for) Cloud Computing [Fall 2023]
School of Engineering and Technology, University of Washington - Tacoma

L5.38

38

CAPACITY PLANNING

Capacity vs. Usage (Traditional Data Center)

October 12, 2023 TCSS462/562:(Software Engineering for) Cloud Computing [Fall 2023]
School of Engineering and Technology, University of Washington - Tacoma L5.39

39

CAPACITY PLANNING - 2

■ Ca

Predictions Cost Money... Capacity-Cost Performance

October 12, 2023 TCSS462/562:(Software Engineering for) Cloud Computing [Fall 2023]
School of Engineering and Technology, University of Washington - Tacoma L5.40

40

BUSINESS DRIVERS FOR CLOUD - 3

- **Cost reduction**
 - IT Infrastructure acquisition
 - IT Infrastructure maintenance

- **Operational overhead**
 - Technical personnel to maintain physical IT infrastructure
 - System upgrades, patches that add testing to deployment cycles
 - Utility bills, capital investments for power and cooling
 - Security and access control measures for server rooms
 - Admin and accounting staff to track licenses, support agreements, purchases

October 12, 2023	TCSS462/562:(Software Engineering for) Cloud Computing [Fall 2023] School of Engineering and Technology, University of Washington - Tacoma	L5.41
------------------	---	-------

41

BUSINESS DRIVERS FOR CLOUD - 4

- **Organizational agility**
 - Ability to adapt and evolve infrastructure to face change from internal and external business factors

 - Funding constraints can lead to insufficient on premise IT

 - Cloud computing enables IT resources to scale with a lower financial commitment

October 12, 2023	TCSS462/562:(Software Engineering for) Cloud Computing [Fall 2023] School of Engineering and Technology, University of Washington - Tacoma	L5.42
------------------	---	-------

42

OBJECTIVES - 10/12

- **Questions from 10/10**
- **Properties of Distributed Systems, Modularity**
- **Introduction to Cloud Computing –based on book #1: Cloud Computing Concepts, Technology & Architecture**
 - **Why study cloud computing?**
 - **History of cloud computing**
 - **Business drivers**
 - **Cloud enabling technologies**
 - **Terminology**
 - **Benefits of cloud adoption**
 - **Risks of cloud adoption**
- **Background on AWS Lambda for the Term Project**

October 12, 2023	TCSS462/562:(Software Engineering for) Cloud Computing [Fall 2023] School of Engineering and Technology, University of Washington - Tacoma	L5.43
------------------	---	-------

43

TECHNOLOGY INNOVATIONS LEADING TO CLOUD

- **Cluster computing**
- **Grid computing**
- **Virtualization**
- **Others**

October 12, 2023	TCSS462/562:(Software Engineering for) Cloud Computing [Fall 2023] School of Engineering and Technology, University of Washington - Tacoma	L5.44
------------------	---	-------

44

CLUSTER COMPUTING



- Cluster computing (clustering)
 - Cluster is a group of independent IT resources interconnected as a single system
 - Servers configured with homogeneous hardware and software
 - Identical or similar RAM, CPU, HDDs
 - Design emphasizes redundancy as server components are easily interchanged to keep overall system running
 - Example: if a RAID card fails on a key server, the card can be swapped from another redundant server
 - Enables warm replica servers
 - Duplication of key infrastructure servers to provide HW failover to ensure high availability (HA)

October 12, 2023	TCSS462/562:(Software Engineering for) Cloud Computing [Fall 2023] School of Engineering and Technology, University of Washington - Tacoma	L5.45
------------------	---	-------

45

GRID COMPUTING



- On going research area since early 1990s
- Distributed heterogeneous computing resources organized into logical pools of loosely coupled resources
- For example: heterogeneous servers connected by the internet
- Resources are heterogeneous and geographically dispersed
- Grids use middleware software layer to support workload distribution and coordination functions
- Aspects: load balancing, failover control, autonomic configuration management
- Grids have influenced clouds contributing common features: networked access to machines, resource pooling, scalability, and resiliency

October 12, 2023	TCSS462/562:(Software Engineering for) Cloud Computing [Fall 2023] School of Engineering and Technology, University of Washington - Tacoma	L5.46
------------------	---	-------

46

GRID COMPUTING - 2

How Grid computing works ?

The diagram illustrates the grid computing architecture. At the top, three user devices (laptop, smartphone, tablet) labeled 'Users' are connected to a central 'Grid Server' (server rack). The Grid Server is connected to a 'Network' (represented by a horizontal line). Below the network, there are multiple 'Grid Clients' (server racks) connected to the network.

In general, a grid computing system requires:

- At least one computer, usually a server, which handles all the administrative duties for the System
- A network of computers running special grid computing network software.
- A collection of computer software called middleware

October 12, 2023	TCSS462/562:(Software Engineering for) Cloud Computing [Fall 2023] School of Engineering and Technology, University of Washington - Tacoma	L5.47
------------------	---	-------

47

VIRTUALIZATION

The diagram shows the layers of virtualization. At the top is the 'Virtual Machine'. Below it is the 'OS Kernel', which contains 'Threads', 'Processes', and 'Drivers'. Below the OS Kernel is the 'Hypervisor', and at the bottom is the 'Hardware'.

October 12, 2023	TCSS462/562:(Software Engineering for) Cloud Computing [Fall 2023] School of Engineering and Technology, University of Washington - Tacoma	L5.48
------------------	---	-------

48

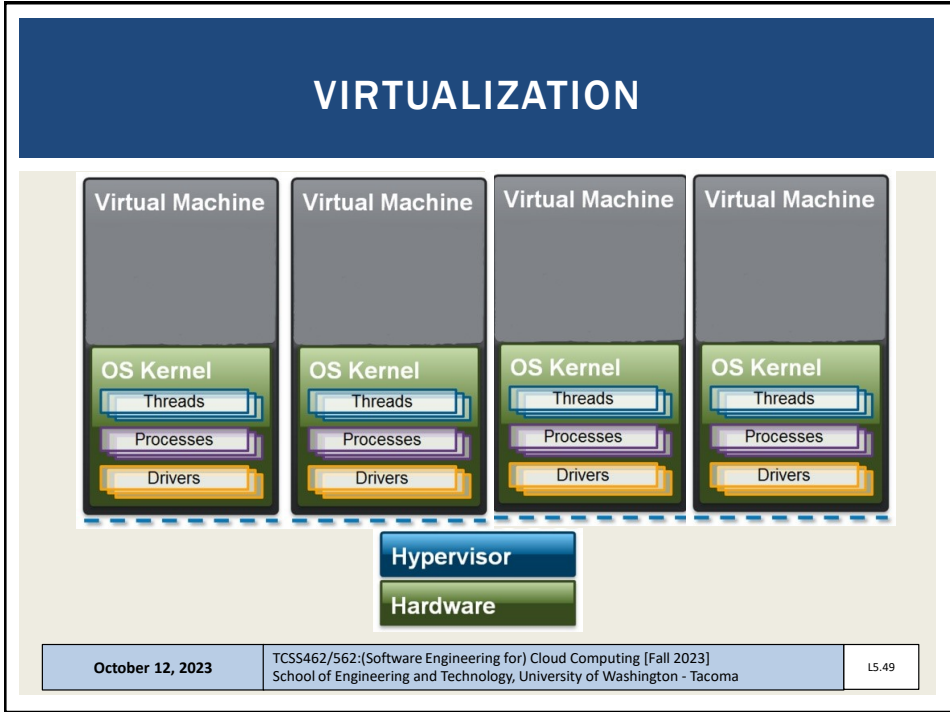

49

The slide features a blue header with the word "VIRTUALIZATION". Below the header, a bulleted list provides key information:

- Simulate physical hardware resources via software
 - The virtual machine (virtual computer)
 - Virtual local area network (VLAN)
 - Virtual hard disk
 - Virtual network attached storage array (NAS)
- Early incarnations featured significant performance, reliability, and scalability challenges
- CPU and other HW enhancements have minimized performance GAPS

At the bottom of the slide, a footer contains the date "October 12, 2023", the course information "TCSS462/562:(Software Engineering for) Cloud Computing [Fall 2023] School of Engineering and Technology, University of Washington - Tacoma", and the slide number "L5.50".

50

OBJECTIVES - 10/12

- **Questions from 10/10**
- **Properties of Distributed Systems, Modularity**
- **Introduction to Cloud Computing –based on book #1: Cloud Computing Concepts, Technology & Architecture**
 - **Why study cloud computing?**
 - **History of cloud computing**
 - **Business drivers**
 - **Cloud enabling technologies**
 - **Terminology**
 - **Benefits of cloud adoption**
 - **Risks of cloud adoption**
- **Background on AWS Lambda for the Term Project**

October 12, 2023	TCSS462/562:(Software Engineering for) Cloud Computing [Fall 2023] School of Engineering and Technology, University of Washington - Tacoma	L5.51
------------------	---	-------

51

KEY TERMINOLOGY

- **On-Premise Infrastructure**
 - Local server infrastructure not configured as a cloud
- **Cloud Provider**
 - Corporation or private organization responsible for maintaining cloud
- **Cloud Consumer**
 - User of cloud services
- **Scaling**
 - **Vertical scaling**
 - Scale up: increase resources of a single virtual server
 - Scale down: decrease resources of a single virtual server
 - **Horizontal scaling**
 - Scale out: increase number of virtual servers
 - Scale in: decrease number of virtual servers

October 12, 2023	TCSS462/562:(Software Engineering for) Cloud Computing [Fall 2023] School of Engineering and Technology, University of Washington - Tacoma	L5.52
------------------	---	-------

52

VERTICAL SCALING

- Reconfigure virtual machine to have different resources:
 - CPU cores
 - RAM
 - HDD/SDD capacity

- May require VM migration if physical host machine resources are exceeded

The diagram illustrates vertical scaling. It shows two virtual machines, A and B, represented as 3D blocks. Machine A is smaller and labeled '2 CPUs'. Machine B is larger and labeled '4 CPUs'. An upward-pointing arrow between them is labeled 'vertical scaling'.

October 12, 2023	TCSS462/562:(Software Engineering for) Cloud Computing [Fall 2023] School of Engineering and Technology, University of Washington - Tacoma	L5.53
------------------	---	-------

53

HORIZONTAL SCALING

- Increase (scale-out) or decrease (scale-in) number of virtual servers based on demand

The diagram illustrates horizontal scaling. At the top, two 'pooled physical servers' are shown. Below them, 'virtual servers' are shown. An initial state shows one virtual server 'A'. An arrow labeled 'demand' points to a state with two virtual servers, 'A' and 'B'. A second arrow labeled 'demand' points to a state with three virtual servers, 'A', 'B', and 'C'. A long arrow at the bottom labeled 'horizontal scaling' points to the right, indicating the direction of increasing the number of servers.

October 12, 2023	TCSS462/562:(Software Engineering for) Cloud Computing [Fall 2023] School of Engineering and Technology, University of Washington - Tacoma	L5.54
------------------	---	-------

54

HORIZONTAL VS VERTICAL SCALING

Horizontal Scaling	Vertical Scaling
Less expensive using commodity HW	Requires expensive high capacity servers

October 12, 2023TCSS462/562:(Software Engineering for) Cloud Computing [Fall 2023]
School of Engineering and Technology, University of Washington - TacomaL5.55

55

HORIZONTAL VS VERTICAL SCALING

Horizontal Scaling	Vertical Scaling
Less expensive using commodity HW	Requires expensive high capacity servers
IT resources instantly available	IT resources typically instantly available

October 12, 2023TCSS462/562:(Software Engineering for) Cloud Computing [Fall 2023]
School of Engineering and Technology, University of Washington - TacomaL5.56

56

HORIZONTAL VS VERTICAL SCALING

Horizontal Scaling	Vertical Scaling
Less expensive using commodity HW	Requires expensive high capacity servers
IT resources instantly available	IT resources typically instantly available
Resource replication and automated scaling	Additional setup is normally needed

October 12, 2023 TCSS462/562:(Software Engineering for) Cloud Computing [Fall 2023]
School of Engineering and Technology, University of Washington - Tacoma L5.57

57

HORIZONTAL VS VERTICAL SCALING

Horizontal Scaling	Vertical Scaling
Less expensive using commodity HW	Requires expensive high capacity servers
IT resources instantly available	IT resources typically instantly available
Resource replication and automated scaling	Additional setup is normally needed
Additional servers required	No additional servers required

October 12, 2023 TCSS462/562:(Software Engineering for) Cloud Computing [Fall 2023]
School of Engineering and Technology, University of Washington - Tacoma L5.58

58

HORIZONTAL VS VERTICAL SCALING

Horizontal Scaling	Vertical Scaling
Less expensive using commodity HW	Requires expensive high capacity servers
IT resources instantly available	IT resources typically instantly available
Resource replication and automated scaling	Additional setup is normally needed
Additional servers required	No additional servers required
Not limited by individual server capacity	Limited by individual server capacity

October 12, 2023 TCSS462/562:(Software Engineering for) Cloud Computing [Fall 2023]
School of Engineering and Technology, University of Washington - Tacoma L5.59

59

KEY TERMINOLOGY - 2

- **Cloud services**
 - Broad array of resources accessible “as-a-service”
 - Categorized as Infrastructure (IaaS), Platform (PaaS), Software (SaaS)

- **Service-level-agreements (SLAs):**
 - Establish expectations for: uptime, security, availability, reliability, and performance

October 12, 2023 TCSS462/562:(Software Engineering for) Cloud Computing [Fall 2023]
School of Engineering and Technology, University of Washington - Tacoma L5.60

60

OBJECTIVES - 10/12

- **Questions from 10/10**
- **Properties of Distributed Systems, Modularity**
- **Introduction to Cloud Computing –based on book #1: Cloud Computing Concepts, Technology & Architecture**
 - **Why study cloud computing?**
 - **History of cloud computing**
 - **Business drivers**
 - **Cloud enabling technologies**
 - **Terminology**
 - **Benefits of cloud adoption**
 - **Risks of cloud adoption**
- **Background on AWS Lambda for the Term Project**

October 12, 2023	TCSS462/562:(Software Engineering for) Cloud Computing [Fall 2023] School of Engineering and Technology, University of Washington - Tacoma	L5.61
------------------	---	-------

61

GOALS AND BENEFITS

- **Cloud providers**
 - **Leverage economies of scale through mass-acquisition and management of large-scale IT resources**
 - **Locate datacenters to optimize costs where electricity is low**
- **Cloud consumers**
 - **Key business/accounting difference:**
 - **Cloud computing enables anticipated capital expenditures to be replaced with operational expenditures**
 - **Operational expenditures always scale with the business**
 - **Eliminates need to invest in server infrastructure based on anticipated business needs**
 - **Businesses become more agile and lower their financial risks by eliminating large capital investments in physical infrastructure**

October 12, 2023	TCSS462/562:(Software Engineering for) Cloud Computing [Fall 2023] School of Engineering and Technology, University of Washington - Tacoma	L5.62
------------------	---	-------

62

CLOUD BENEFITS - 2

- On demand access to pay-as-you-go resources on a short-term basis (less commitment)
- Ability to acquire “unlimited” computing resources on demand when required for business needs
- Ability to add/remove IT resources at a fine-grained level
- Abstraction of server infrastructure so applications deployments are not dependent on specific locations, hardware, etc.
 - The cloud has made our software deployments more agile...



October 12, 2023	TCSS462/562:(Software Engineering for) Cloud Computing [Fall 2023] School of Engineering and Technology, University of Washington - Tacoma	L5.63
------------------	---	-------

63

CLOUD BENEFITS - 3

- Example: Using 100 servers for 1 hour costs the same as using 1 server for 100 hours
- Rosetta Protein Folding: Working with a UW-Tacoma graduate student, we recently deployed this science model across 5,900 compute cores on Amazon for 2-days...
- ***What is the cost to purchase 5,900 compute cores?***
- Recent Dell Server purchase example:
20 cores on 2 servers for \$4,478...
- Using this ratio 5,900 cores costs \$1.3 million (purchase only)

October 12, 2023	TCSS462/562:(Software Engineering for) Cloud Computing [Fall 2023] School of Engineering and Technology, University of Washington - Tacoma	L5.64
------------------	---	-------

64



65

CLOUD BENEFITS

- Increased scalability
 - Example demand over a 24-hour day →
- Increased availability
- Increased reliability

Time (h)	Concurrent Users
2	1,500
4	1,000
6	1,500
8	2,500
10	5,000
12	8,000
14	9,000
16	9,500
18	8,000
20	4,000
22	2,500
24	2,000

October 12, 2023	TCSS462/562:(Software Engineering for) Cloud Computing [Fall 2023] School of Engineering and Technology, University of Washington - Tacoma	L5.66
------------------	---	-------

66

OBJECTIVES - 10/12

- **Questions from 10/10**
- **Properties of Distributed Systems, Modularity**
- **Introduction to Cloud Computing –based on book #1: Cloud Computing Concepts, Technology & Architecture**
 - **Why study cloud computing?**
 - **History of cloud computing**
 - **Business drivers**
 - **Cloud enabling technologies**
 - **Terminology**
 - **Benefits of cloud adoption**
 - **Risks of cloud adoption**
- **Background on AWS Lambda for the Term Project**

October 12, 2023	TCSS462/562:(Software Engineering for) Cloud Computing [Fall 2023] School of Engineering and Technology, University of Washington - Tacoma	L5.67
------------------	---	-------

67

CLOUD ADOPTION RISKS

- **Increased security vulnerabilities**
 - **Expansion of trust boundaries now include the external cloud**
 - **Security responsibility shared with cloud provider**
- **Reduced operational governance / control**
 - **Users have less control of physical hardware**
 - **Cloud user does not directly control resources to ensure quality-of-service**
 - **Infrastructure management is abstracted**
 - **Quality and stability of resources can vary**
 - **Network latency costs and variability**

October 12, 2023	TCSS462/562:(Software Engineering for) Cloud Computing [Fall 2023] School of Engineering and Technology, University of Washington - Tacoma	L5.68
------------------	---	-------

68

NETWORK LATENCY COSTS

The diagram shows two organizational boundaries: 'Organization A' (left) and 'Cloud A' (right). Organization A contains a 'cloud service consumer' (blue box). Cloud A contains a 'cloud service' (yellow circle). Both are connected to 'reliable network' (grey boxes). The connection between the consumer and the service is labeled 'unreliable network connection' (grey box) and is marked with a red lightning bolt icon. Below the diagram is a footer with the date 'October 12, 2023', the course information 'TCSS462/562:(Software Engineering for) Cloud Computing [Fall 2023] School of Engineering and Technology, University of Washington - Tacoma', and the slide number 'L5.69'.

69

CLOUD RISKS - 2

- **Performance monitoring of cloud applications**
 - Cloud metrics (AWS cloudwatch) support monitoring cloud infrastructure (network load, CPU utilization, I/O)
 - Performance of cloud applications depends on the health of aggregated cloud resources working together
 - User must monitor this aggregate performance
- **Limited portability among clouds**
 - Early cloud systems have significant “vendor” lock-in
 - Common APIs and deployment models are slow to evolve
 - Operating system containers help make applications more portable, but containers still must be deployed
- **Geographical issues**
 - Abstraction of cloud location leads to legal challenges with respect to laws for data privacy and storage

October 12, 2023 TCSS462/562:(Software Engineering for) Cloud Computing [Fall 2023] School of Engineering and Technology, University of Washington - Tacoma L5.70

70

CLOUD: VENDOR LOCK-IN

The diagram shows a cloud consumer on the left. Two arrows point from the consumer to two cloud providers, Cloud A and Cloud B. Cloud A is labeled 'Cloud A (Cloud Provider X)' and contains a server icon. A callout box next to Cloud A says 'supports message encryption and digital signatures'. A callout box next to the consumer says 'requires encryption and digital signing of messages'. Cloud B is labeled 'Cloud B (Cloud Provider Y)' and also contains a server icon. A callout box next to Cloud B says 'supports message encryption only'. A lightning bolt symbol is placed between the two cloud providers, indicating a dependency or transition.

October 12, 2023	TCSS462/562:(Software Engineering for) Cloud Computing [Fall 2023] School of Engineering and Technology, University of Washington - Tacoma	L5.71
------------------	---	-------

71

OBJECTIVES - 10/12

- Questions from 10/10
- Properties of Distributed Systems, Modularity
- Introduction to Cloud Computing –based on book #1: Cloud Computing Concepts, Technology & Architecture
 - Why study cloud computing?
 - History of cloud computing
 - Business drivers
 - Cloud enabling technologies
 - Terminology
 - Benefits of cloud adoption
 - Risks of cloud adoption
- Background on AWS Lambda for the Term Project

October 12, 2023	TCSS462/562:(Software Engineering for) Cloud Computing [Fall 2023] School of Engineering and Technology, University of Washington - Tacoma	L5.72
------------------	---	-------

72

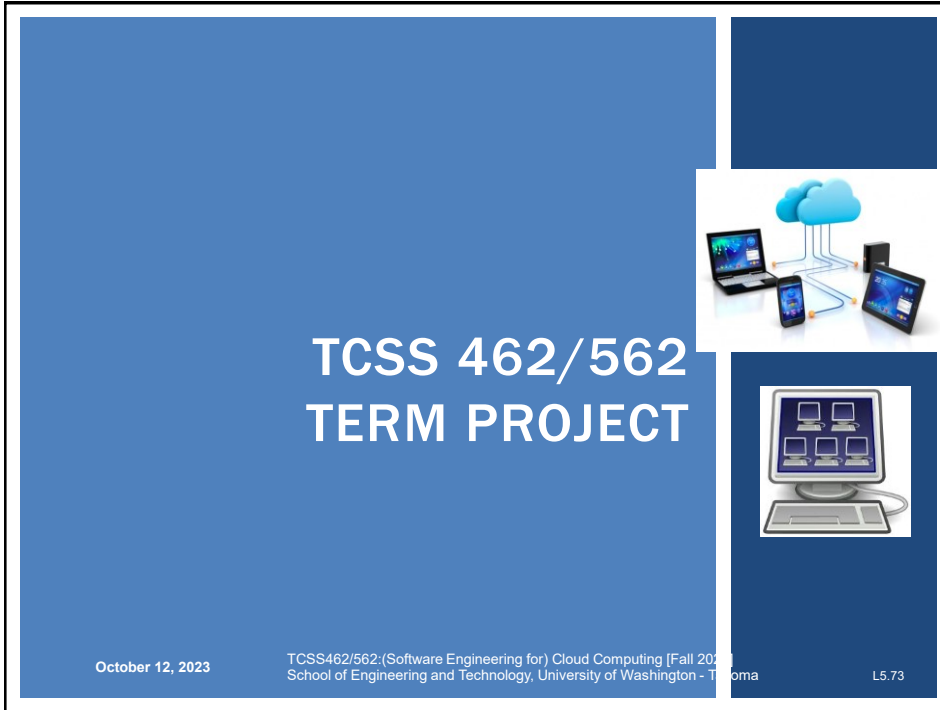

TCSS 462/562
TERM PROJECT

October 12, 2023

TCSS462/562:(Software Engineering for) Cloud Computing [Fall 2023]
School of Engineering and Technology, University of Washington - Tacoma

L5.73

The slide features a large blue background with the title 'TCSS 462/562 TERM PROJECT' in white. On the right side, there are two images: the top one shows a cloud connected to a laptop, a smartphone, and a tablet; the bottom one shows a computer monitor displaying a network diagram. At the bottom, there is a footer with the date 'October 12, 2023', the course name 'TCSS462/562:(Software Engineering for) Cloud Computing [Fall 2023]', the school name 'School of Engineering and Technology, University of Washington - Tacoma', and the slide number 'L5.73'.

73

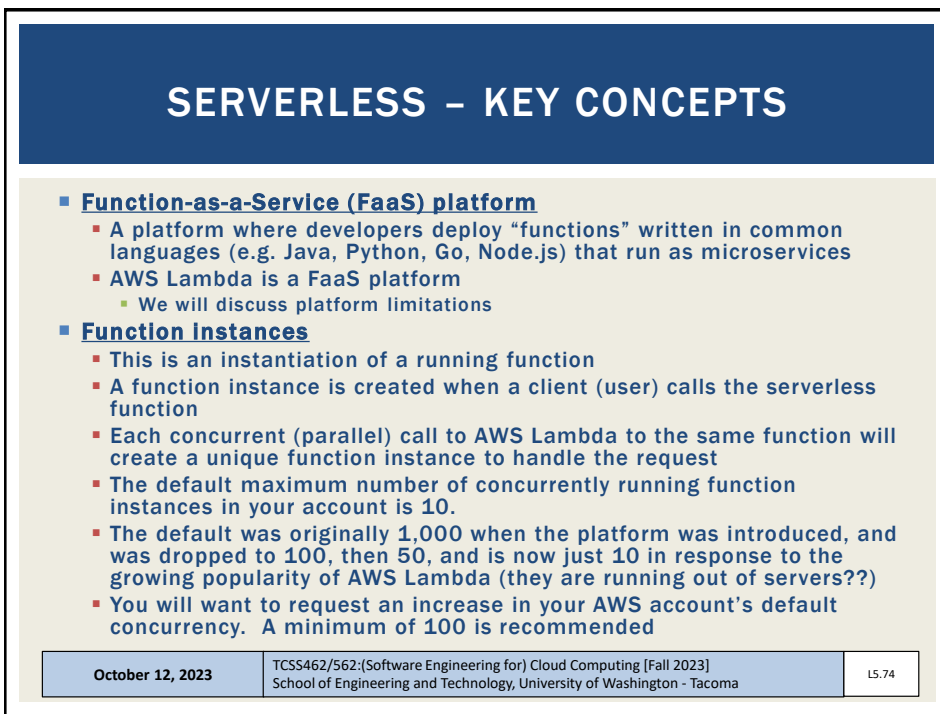

SERVERLESS – KEY CONCEPTS

- **Function-as-a-Service (FaaS) platform**
 - A platform where developers deploy “functions” written in common languages (e.g. Java, Python, Go, Node.js) that run as microservices
 - AWS Lambda is a FaaS platform
 - We will discuss platform limitations
- **Function Instances**
 - This is an instantiation of a running function
 - A function instance is created when a client (user) calls the serverless function
 - Each concurrent (parallel) call to AWS Lambda to the same function will create a unique function instance to handle the request
 - The default maximum number of concurrently running function instances in your account is 10.
 - The default was originally 1,000 when the platform was introduced, and was dropped to 100, then 50, and is now just 10 in response to the growing popularity of AWS Lambda (they are running out of servers??)
 - You will want to request an increase in your AWS account's default concurrency. A minimum of 100 is recommended

October 12, 2023

TCSS462/562:(Software Engineering for) Cloud Computing [Fall 2023]
School of Engineering and Technology, University of Washington - Tacoma

L5.74

The slide has a dark blue header with the title 'SERVERLESS – KEY CONCEPTS' in white. The main content is on a light beige background and consists of a bulleted list of key concepts. The footer is a light blue bar with the date 'October 12, 2023', the course name 'TCSS462/562:(Software Engineering for) Cloud Computing [Fall 2023]', the school name 'School of Engineering and Technology, University of Washington - Tacoma', and the slide number 'L5.74'.

74

AWS LAMBDA

- Lambda functions can be invoked by creating an HTTP REST endpoint that responds to HTTP POST requests
- A json object is provided as a request object to the function
- In the function code, the request object can be accessed to interpret how the user parameterized the function call
- The function generates a JSON response object
- AWS Lambda is introduced in detail in Tutorial 4

October 12, 2023	TCSS462/562:(Software Engineering for) Cloud Computing [Fall 2023] School of Engineering and Technology, University of Washington - Tacoma	L5.75
------------------	---	-------

75

TYPES OF FUNCTION CALLS: SYNCHRONOUS

- **Serverless Computing:**
- AWS Lambda supports synchronous and asynchronous function calls
- Clients typically orchestrate synchronous calls and pipelines
- Asynchronous calls are often made via events
- **Synchronous web service:**
- Client calls service
- Client blocks (freezes) and waits for server to complete call
- Connection is maintained in the "OPEN" state
- Problematic if service runtime is long!
 - Connections are notoriously dropped
 - System timeouts reached
- Client can't do anything while waiting unless using threads

October 12, 2023	TCSS462/562:(Software Engineering for) Cloud Computing [Fall 2023] School of Engineering and Technology, University of Washington - Tacoma	L5.76
------------------	---	-------

76

TYPES OF FUNCTION CALLS: ASYNCHRONOUS

- **Asynchronous web service**
- Client calls service
- Server responds to client with OK message
- Client closes connection
- Server performs the work associated with the service
- Server posts service result in an external data store
 - AWS: S3, SQS (queueing service), SNS (notification service)

October 12, 2023	TCSS462/562:(Software Engineering for) Cloud Computing [Fall 2023] School of Engineering and Technology, University of Washington - Tacoma	L5.77
------------------	---	-------

77

AWS LAMBDA PLATFORM LIMITATIONS

- Maximum 10 GB memory per function instance
- Maximum 15-minutes execution per function instance
- 500 MB of /tmp disk space for local I/O (default)
- Up to 10 GB /tmp ephemeral storage (for additional charge)
 - <https://aws.amazon.com/blogs/aws/aws-lambda-now-supports-up-to-10-gb-ephemeral-storage/>
- Access up to 6 vCPUs depending on memory reservation size

Memory (MBs)	Cores	Speedup	Theoretical Speedup
0	2	1	1
2000	2	2	2
3000	3	3	3
4000	3	4	4
5000	4	5	5
6000	4	6	6
7000	5	7	7
8000	5	8	8
9000	6	9	9
10000	6	10	10

Figure 1: AWS Lambda Performance Speedup for Sysbench Prime Number Generation vs. Function Memory

October 12, 2023	TCSS462/562:(Software Engineering for) Cloud Computing [Fall 2023] School of Engineering and Technology, University of Washington - Tacoma	L5.78
------------------	---	-------

78

AWS LAMBDA PLATFORM LIMITATIONS - 2

- 10 concurrent function executions inside account (default)
- Function payload: 6MB (synchronous), 256KB (asynchronous)
- Deployment package: 50MB (compressed), 250MB (unzipped)
- Container image size: 10 GB
- Processes/threads: 1024
- File descriptors: 1024
- Function instances run Amazon Linux 2
 - Pending upgrade to Amazon Linux 2023 ?
- See: <https://docs.aws.amazon.com/lambda/latest/dg/gettingstarted-limits.html>

October 12, 2023	TCSS462/562:(Software Engineering for) Cloud Computing [Fall 2023] School of Engineering and Technology, University of Washington - Tacoma	L5.79
------------------	---	-------

79

CPUSTEAL

- *CpuSteal*: Metric that measures when a CPU core is ready to execute but the physical CPU core is busy and unavailable
- Symptom of over provisioning physical servers in the cloud
- Factors which cause *CpuSteal*: (x86 hyperthreading)
 1. Physical CPU is shared by too many busy VMs
 2. Hypervisor kernel is using the CPU
 - On AWS Lambda this would be the Firecracker MicroVM which is derived from the KVM hypervisor
 3. VM's CPU time share <100% for 1 or more cores, and 100% is needed for a CPU intensive workload.
- Man procs - press "/" - type "proc/stat"
 - CpuSteal is the 8th column returned
 - Metric can be read using SAAF in tutorial #4

October 12, 2023	TCSS462/562:(Software Engineering for) Cloud Computing [Fall 2023] School of Engineering and Technology, University of Washington - Tacoma	L5.80
------------------	---	-------

80

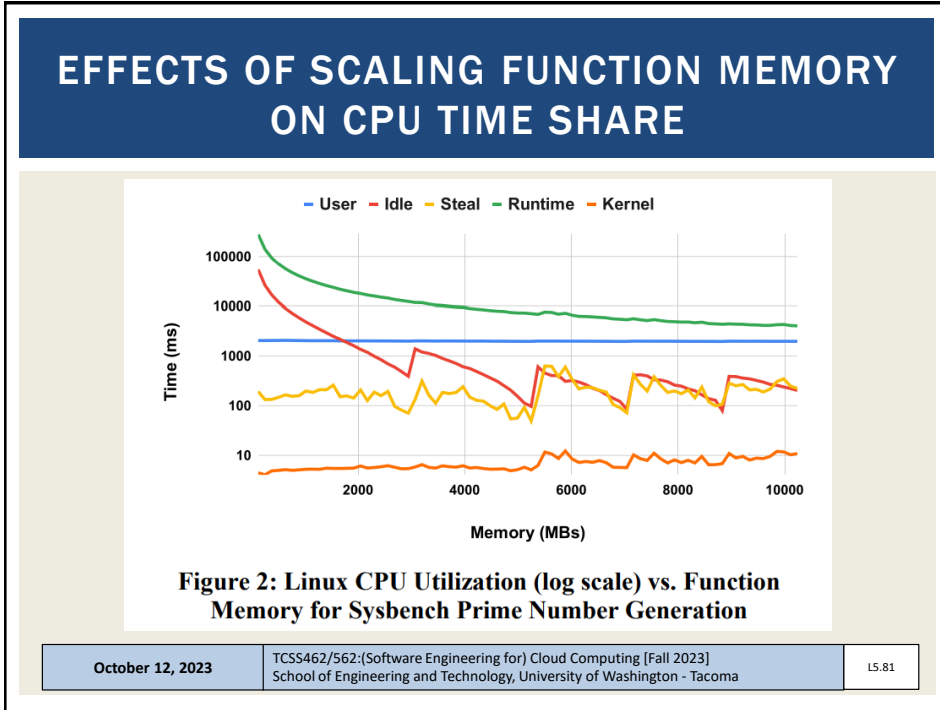

81

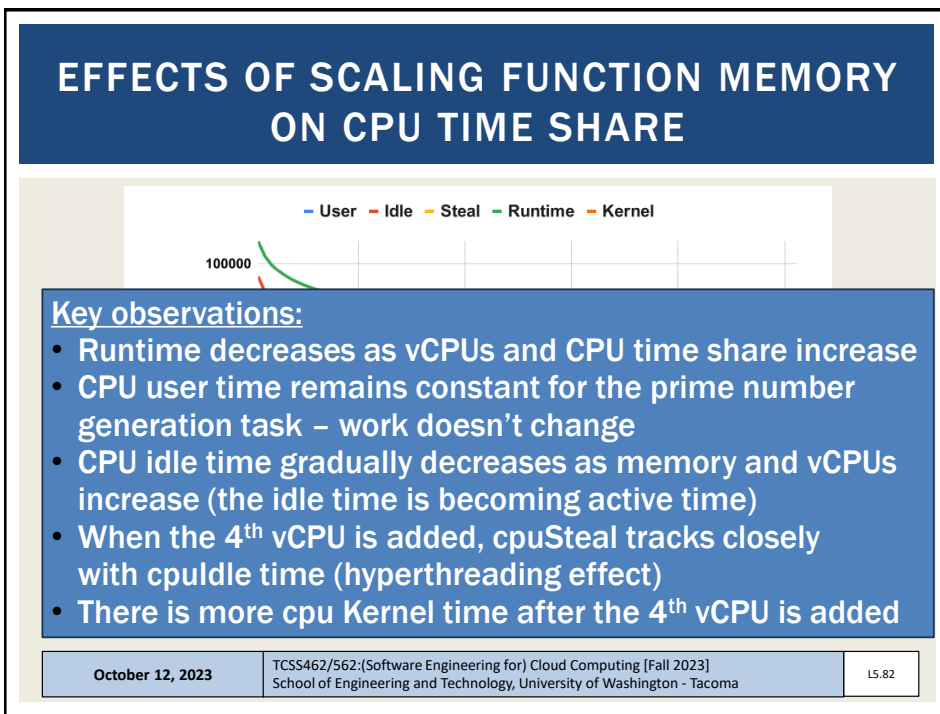

82

FUNCTION INSTANCE LIFE CYCLES

- **Function states:**
- **COLD:** brand new function instance just initialized to run the request (more overhead)
 - Platform cold (first time ever run)
 - Host cold (function assets cached locally on servers)
- **WARM:** existing function instance that is reused
- All function instances persist for ~5 minutes before they begin to be “garbage collected” by the platform
 - 100% garbage collection may take up to ~30-40 minutes
- AWS Lambda appears to “recycle” infrastructure faster than other FaaS platforms
 - Presumably because of need, because the platform is busy

October 12, 2023

TCSS462/562:(Software Engineering for) Cloud Computing [Fall 2023]
School of Engineering and Technology, University of Washington - Tacoma

L5.83

83

WARM VS COLD FUNCTION INSTANCES

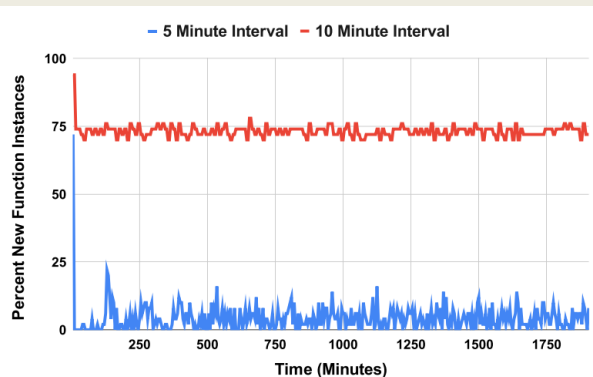

Figure 3: AWS Lambda Function Instance Replacement vs. Function Call Interval over 24-hours

October 12, 2023

TCSS462/562:(Software Engineering for) Cloud Computing [Fall 2023]
School of Engineering and Technology, University of Washington - Tacoma

L9.84

84

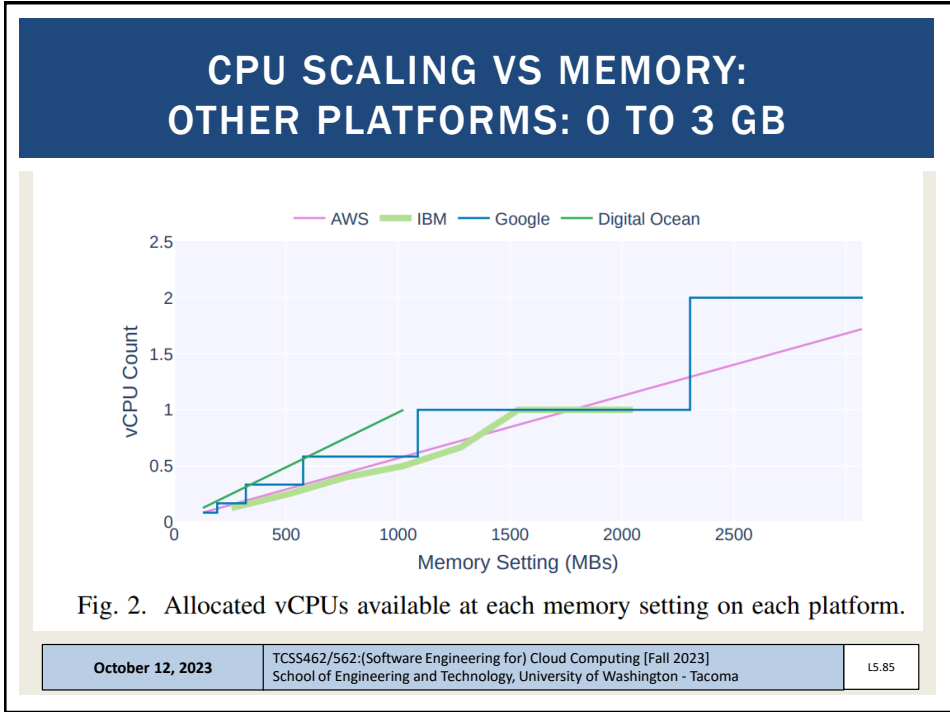

85

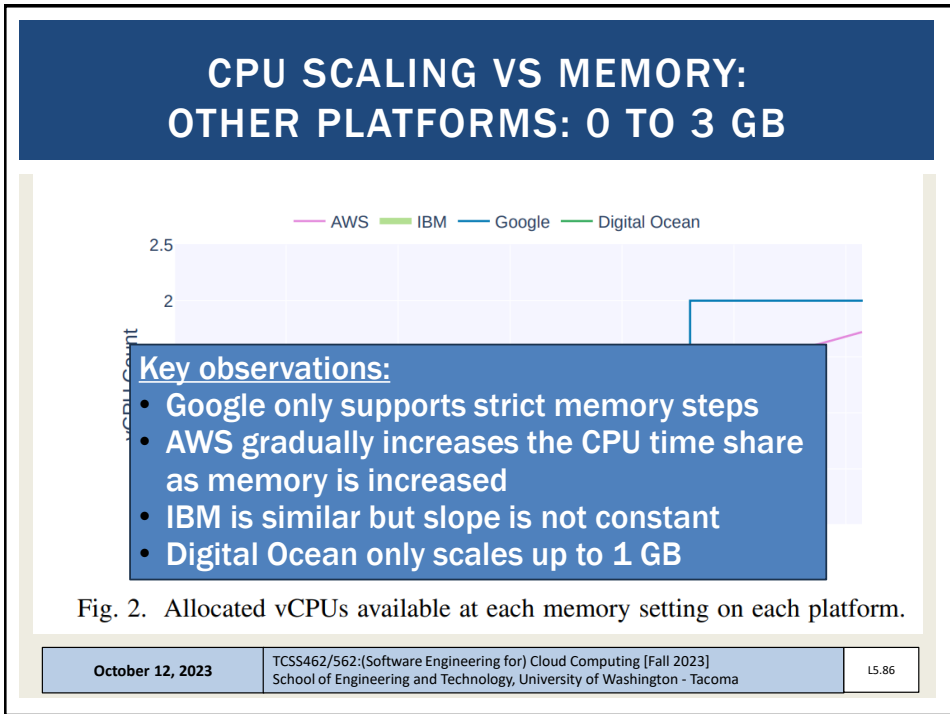

86

ELASTIC FILE SYSTEM (AWS EFS)

- Traditionally AWS Lambda functions have been limited to 500MB of storage space
- Recently the Elastic File System (EFS) has been extended to support AWS Lambda
- The Elastic File System supports the creation of a shared volume like a shared disk (or folder)
 - EFS is similar to NFS (network file share)
 - Multiple AWS Lambda functions and/or EC2 VMs can mount and share the same EFS volume
 - Provides a shared R/W disk
 - Breaks the 500MB capacity barrier on AWS Lambda
- **Downside: EFS is expensive: ~30 \$/GB/month**
- **Project: EFS performance & scalability evaluation on Lambda**

October 12, 2023

TCSS462/562:(Software Engineering for) Cloud Computing [Fall 2023]
School of Engineering and Technology, University of Washington - Tacoma

L5.87

87

SERVERLESS FILE STORAGE COMPARISON PROJECT

- Elastic File System (EFS):
Performance, Cost, and Scalability Evaluation in the context of AWS Lambda / Serverless Computing
 - EFS provides a file system that can be shared with multiple Lambda function instances in parallel
- Using a common use case, compare performance and cost of extended storage options on AWS Lambda:
 - Docker container support (up to 10 GB) – read only
 - Ephemeral /tmp (up to 10 GB) – read/write
 - EFS (unlimited, but costly) – read/write
 - image integration with AWS Lambda – performance & scalability

October 12, 2023

TCSS462/562:(Software Engineering for) Cloud Computing [Fall 2023]
School of Engineering and Technology, University of Washington - Tacoma

L5.88

88

SERVICE COMPOSITION

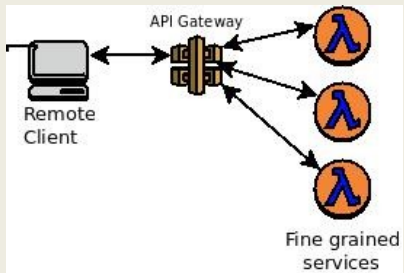

A	B	C	3 services Full Service Isolation
A B C			2 services
A B C			2 services
A B C			1 service Full Service Aggregation

Other possible compositions: group by library, functional cohesion, etc.

October 12, 2023	TCSS462/562:(Software Engineering for) Cloud Computing [Fall 2023] School of Engineering and Technology, University of Washington - Tacoma	L5.89
------------------	---	-------

89

SWITCH-BOARD ARCHITECTURE

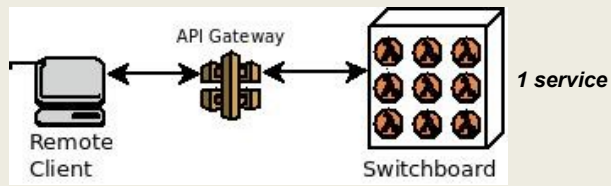

Single deployment package with consolidated codebase (Java: one JAR file)

Entry method contains "switchboard" logic
 Case statement that route calls to proper service

Routing is based on data payload
 Check if specific parameters exist, route call accordingly

Goal: reduce # of COLD starts to improve performance

October 12, 2023	TCSS462/562:(Software Engineering for) Cloud Computing [Fall 2023] School of Engineering and Technology, University of Washington - Tacoma	L5.90
------------------	---	-------

90

APPLICATION FLOW CONTROL - 3

Client flow control

(a) Microservices

Microservice as controller

(c) Microservices

AWS Step Function

(b) Microservices

Asynchronous

(d)

October 12, 2023	TCSS462/562:(Software Engineering for) Cloud Computing [Fall 2023] School of Engineering and Technology, University of Washington - Tacoma	L5.91
------------------	---	-------

91

PROGRAMMING LANGUAGE COMPARISON

- FaaS platforms support hosting code in multiple languages
- AWS Lambda- common: Java, Node.js, Python
 - Plus others: Go, PowerShell, C#, and Ruby
- Also Runtime API (“BASH”) which allows deployment of binary executables from any programming language
- August 2020 – Our group’s paper:
- <https://tinyurl.com/y46eq6np>
- If wanting to perform a language study either:
 - Implement in C#, Ruby, or multiple versions of Java, Node.js, Python
 - OR implement different app than TLQ (ETL) data processing pipeline

October 12, 2023	TCSS462/562:(Software Engineering for) Cloud Computing [Fall 2023] School of Engineering and Technology, University of Washington - Tacoma	L5.92
------------------	---	-------

92

FAAS PLATFORMS

- Many commercial and open source FaaS platforms exist
- TCSS562 projects can choose to compare performance and cost implications of alternate platforms.

- Supported by SAAF:
 - AWS Lambda
 - Google Cloud Functions
 - Azure Functions
 - IBM Cloud Functions
 - Apache OpenWhisk (*open source, deploy your own FaaS*)
 - Open FaaS (*open source, deploy your own FaaS*)

October 12, 2023

TCSS462/562:(Software Engineering for) Cloud Computing [Fall 2023]
School of Engineering and Technology, University of Washington - Tacoma

L5.93

93

DATA PROVISIONING

- Consider performance and cost implications of the data-tier design for the serverless application
- Use different tools as the relational datastore to support service #2 (LOAD) and service #3 (EXTRACT)

- **SQL / Relational:**
 - Amazon Aurora (serverless cloud DB), Amazon RDS (cloud DB), DB on a VM (MySQL), DB inside Lambda function (SQLite, Derby)

- **NO SQL / Key/Value Store:**
 - Dynamo DB, MongoDB, S3

October 12, 2023

TCSS462/562:(Software Engineering for) Cloud Computing [Fall 2023]
School of Engineering and Technology, University of Washington - Tacoma

L5.94

94

PERFORMANCE VARIABILITY

- Cloud platforms exhibit performance variability which varies over time
- Goal of this case study is to measure performance variability (i.e. extent) for AWS Lambda services by hour, day, week to look for common patterns
- Can also examine performance variability by availability zone and region
 - Do some regions provide more stable performance?
 - Can services be switched to different regions during different times to leverage better performance?
- Remember that performance = cost
- If we make it faster, we make it cheaper...

October 12, 2023

TCSS462/562:(Software Engineering for) Cloud Computing [Fall 2023]
School of Engineering and Technology, University of Washington - Tacoma

L5.95

95

CPU STEAL CASE STUDY

- On AWS Lambda (or other FaaS platforms), when we run functions, how much CpuSteal do we observe?
- How does CpuSteal vary for different workloads? (e.g. functions that have different resource requirements)
- How does CpuSteal vary over time hour, day, week, location?
- How does CpuSteal relate to function performance?

October 12, 2023

TCSS462/562:(Software Engineering for) Cloud Computing [Fall 2023]
School of Engineering and Technology, University of Washington - Tacoma

L5.96

96

QUESTIONS

October 12, 2023

TCSS462/562: (Software Engineering for) Cloud Computing [Fall 2023]
School of Engineering and Technology, University of Washington - Tacoma

L5.97

97