

Analysis of Response Patterns of LGN Cells*

RUSSELL L. DE VALOIS, ISRAEL ABRAMOV, AND GERALD H. JACOBS†
Department of Psychology, Indiana University, Bloomington, Indiana 47401
(Received 10 December 1965)

A detailed analysis was made of the response characteristics of single cells in the lateral geniculate nucleus of the macaque monkey. The goal was to understand how these cells contribute to the processing of visual information. Data were analyzed from a representative sample of 147 cells, whose responses to equal-energy spectra (presented as diffuse flashes of monochromatic light) were recorded at three radiance levels. On the basis of their responses, the cells were divided into two general classes: (a) spectrally nonopponent cells which respond to all wavelengths with either an increase or decrease in firing rate, (b) spectrally opponent cells (about two-thirds of the sample) which respond with an increase in firing rate to some parts of the spectrum and a decrease to other parts. Four types of opponent cells were found: (i) red excitatory and green inhibitory (+R-G), (ii) green excitatory and red inhibitory (+G-R), (iii) yellow excitatory and blue inhibitory (+Y-B), (iv) blue excitatory and yellow inhibitory (+B-Y). Comparisons with psychophysical data indicated that nonopponent cells transmit brightness information; opponent cells, however, carry information about color, the hue of a light being determined by the relative responses of the four types. The saturation of spectral lights appears to be related to the differences in responses of opponent and non-opponent cells.

INDEX HEADINGS: Vision; Color vision.

I. INTRODUCTION

THIS paper deals with the question of how information is encoded and analyzed in the visual system, particularly with reference to color vision.

For decades, interest has focused mainly on the nature of the visual photopigments. Evidence from many different lines of investigation (especially microspectrophotometry by Marks, Dobbelle, and MacNichol in 1964,¹ and by Brown and Wald in 1964²) shows that primate cones probably contain three different photopigments, all of broad spectral sensitivity corresponding closely to the Dartnall nomogram, with absorption

maxima at approximately 440, 540, and 570 nm; each receptor contains only one of the pigments.¹

This concentration of interest on the photopigments led many to ignore the equally important question of how the information from the receptors is processed by the nervous system. Many psychophysical procedures, for instance, are designed, whether explicitly or not, to make the absorption characteristics of the photopigments the sole factor determining the results obtained; as a result they provide essentially no information about the neural processes. We need both psychophysical experiments which relate the input to the final output of the visual system, as well as physiological studies which examine the neural processing that intervenes.

Perhaps the simplest and most fundamental questions about color vision are how the basic parameters of color sensation (hue, saturation, brightness) are encoded in the visual pathway. One way of examining this question is by a direct comparison of psychophysical with physio-

* The research reported here was supported by USPHS Grant NB-02274, and NSF Grant No. G-24125.

† Present address: Department of Psychology, University of Texas, Austin, Texas 78712.

¹ W. B. Marks, W. H. Dobbelle, and E. F. MacNichol, Jr., *Science* 143, 1181 (1964).

² P. K. Brown and G. Wald, *Science* 144, 45 (1964).

logical experiments; a stimulus is varied in the same way in both situations and the resulting changes in the psychophysical parameters are compared with the recorded variations in the responses of single visual cells. One such variable might be wavelength; hue, saturation, and brightness all vary with wavelength but in different ways. If these three types of information are separately encoded, different cells should be found whose responses vary with wavelength in the same way as do hue, saturation, or brightness.

In the past, such a comparison has often been made for brightness. The luminosity function of an organism shows how brightness varies as a function of wavelength. For example, Granit,³ recording from ganglion cells in the cat and several other animals, found that the amount of light required for a certain criterion firing rate corresponds to the presumed luminosity curve of the animal; he presented this as evidence that these ganglion cells, which he called dominators, carry brightness information. An extension of this approach to hue and saturation would provide an essential basis for more detailed analyses of the functioning of the visual nervous system in organisms possessing color vision.

It has been assumed in this discussion that information is available about the manner in which these percepts vary with wavelength in the animals from which the physiological recordings are made. The major psychophysical studies, however, used human subjects from whom it is clearly not possible to obtain single-cell recordings. But previous work had indicated that the visual system of the macaque monkey is very similar to that of man; for this reason we chose it as the experimental subject. The behavioral observations were extended to a direct comparison of macaque and human subjects in a variety of basic psychophysical experiments. The results of these psychophysical tests, as yet unpublished, indicate that the visual capabilities of

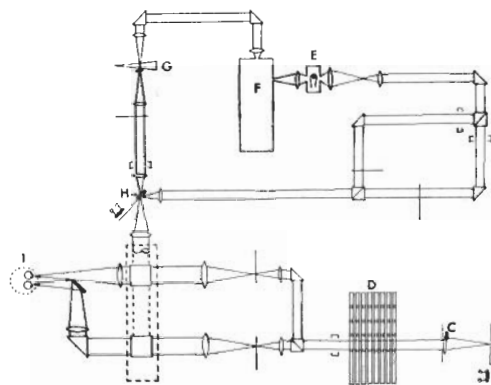

FIG. 1. Optical system: A, zirconium arc; B, shutter; C, signal marker; D, interference and neutral density filter racks; E, tungsten lamp; F, grating monochromator; G, neutral density wedge; H, mirror on shutter arm; I, monkey with Maxwellian view.

³ R. Granit, *Receptors and Sensory Perception* (Yale University Press, New Haven, Conn., 1955).

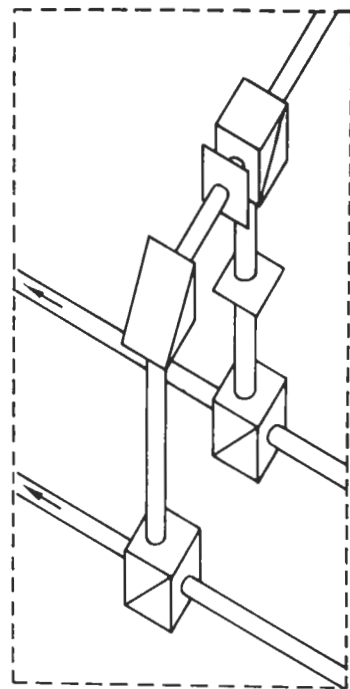

FIG. 2. Detail of junctions of upper and lower beams in optical system.

these two species are remarkably similar, which may justify some application of physiological data from macaques to humans.

II. METHOD

Subjects

The subjects in the physiological experiments were 2- to 4-kg macaques (*Macaca irus*) maintained under light barbiturate anesthesia throughout an experiment. The animals were held in a stereotaxic instrument and were aligned with the optical system. Single cells in the lateral geniculate nucleus (LGN) of the thalamus were electrically isolated with micropipettes (filled with 3M KCl and having tips of about 1μ in diameter) lowered through a trephine hole in the skull. Recordings were extracellular. The output of the electrode was amplified in the usual way and filmed from an oscilloscopic display.

Optical System

In the principal beam (Fig. 1), the arc from a zirconium lamp was imaged at an aperture containing an electromagnetic shutter. The beam was then collimated and passed through interference and neutral density filters, split into two beams, and finally brought to a focus at the plane of the pupils of the animal's eyes thus presenting him with a Maxwellian view subtending about 15° . In addition, beam splitters were used to bring light from the other subsidiary part of the optical system (see Fig. 2). In this portion, light from a tungsten source was passed through a grating monochromator

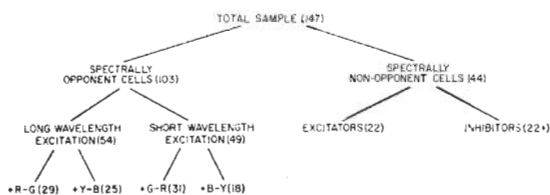

FIG. 3. Classification of the cells in the sample reported here. Numbers in parentheses refer to the number of cells in each category.

or through a path in which filters could be inserted; the beams, at right angles to each other, were brought to a focus in the plane of a mirror mounted on a shutter arm. This allowed one or the other of these beams to pass through to the main beams. All the beams could be independently blocked. In the experiments described here the subsidiary beams provided chromatic or achromatic adaptation light.

In the main beam, spectral lights were obtained from narrow bandwidth Baird-Atomic interference filters; Wratten neutral density filters were used to equate the energies transmitted by the several interference filters. In the absence of additional neutral density filters, the energy flux incident at either cornea was about 7.5 erg/sec, as measured with a Schwarz vacuum thermopile placed at the focal point.

Procedure

The animal was maintained under a low level of light adaptation. When a cell was isolated, a flash of light was presented to each eye to determine the responsive eye. There is no binocular interaction up to this point in the macaque visual system; each LGN cell responds to light from only one eye; the projections from the two eyes are interdigitated in layers through the nucleus. When the appropriate eye had been determined, the spectral response of the cell was determined by recording the responses to light flashes of 12 different wavelengths equated for energy. These were each one second in duration, and were presented in random order, with a 30- to 60-sec pause between flashes. The responsiveness of the cell was measured first at an intermediate radiance usually half a log unit below maximum, and then at two other radiances one-half log units above and below the first. The number of spikes in the one-second periods before, during, and after the flash were counted to obtain the spontaneous firing rate, the on-response, and the off-response, respectively. The fact that there is a definite but variable latency between the onset of the light and the arrival of impulses at the LGN presents a complication. Neglect of latency would certainly introduce errors, but adjusting the latency in each case depending on the response would allow the experimenter's biases to influence the results. Since, in those cases where the onset of the response is clear-cut, the latency is almost always somewhat over 50 msec, this

was taken as the standard latency. The spontaneous rate, therefore, is the number of spikes in a one-second period extending from 950 msec before the light onset to 50 msec after; this was averaged across all the responses of a particular cell to give that cell's average spontaneous firing rate. The "during" rate was the number of spikes in the one-second period extending from 50 msec after the light onset to 50 msec after extinction. The off-response, not discussed here, extended for the period beyond 50 msec from light extinction. After the spectral response of the cell had been determined, additional experiments were carried out; only the spectral response data are discussed here.

III. RESULTS AND DISCUSSION

The results of a detailed analysis of 147 cells in the macaque monkey LGN are reported here. These 147 comprise all the cells, out of a very much larger sample of LGN cells, from which spectral response data were available at three radiance levels covering a range of one log unit. To ensure that these selected cells were an unbiased sample of the total recorded population, their response curves were compared with other cells from which only limited spectral data were obtained; no significant differences were found. It is assumed that the cells recorded constitute a random sample of all the LGN cells receiving their projections from the central retinal area; records were obtained only infrequently from peripherally related cells.

(1) Classification of Cells

One obvious way in which information may be encoded in sensory systems is by transmission along separate channels. The first question we ask is whether or not there appear to be different functional types of cells in the LGN and, if so, how many different types.

In the absence of a stimulus, LGN cells are "spontaneously" active; differences from this spontaneous rate constitute responses. Thus, if we consider only the number of spikes during the whole response interval, there are three possible responses to diffuse monochromatic light. The cell may respond with increased firing rate (excitation) to all wavelengths, with decreased firing rate (inhibition) to all wavelengths, or with increased firing rate to some wavelengths and decreased firing rate to others. (We use the terms excitation and inhibition to mean nothing other than an increase or a decrease in firing rate of the LGN cells. The terms do not necessarily imply that the LGN cell itself is subjected to excitation or inhibition.) Cells falling into each of these three categories are in fact found. We have termed these spectrally nonopponent (excitators or inhibitors), and spectrally opponent, respectively. The classification refers only to whether or not there appear to be opposing *spectral* mechanisms involved in the behavior of the cell; there may or may not be opponent

spatial processes involved as well, but that variable is not considered here. Thus the first large division of LGN cells in our sample is into opponent and nonopponent cells. It can be seen from Fig. 3 that opponent cells comprise about two-thirds of the centrally related visual pathway, and the nonopponent cells about one third.

Opponent Cells—General Classification

The spectrally opponent cells can in turn be grouped on the basis of which wavelengths produce excitation and which produce inhibition. It is clear from an examination of the points at which peak excitation (or peak inhibition) occurs that there is a wide variety of opponent cells. Despite this, certain clear differences between cells enable us to classify them. Some cells show their maximum excitatory response to long wavelengths and are inhibited by short wavelengths, whereas others are maximally excited by short wavelengths and inhibited by long. This provides a reasonably unambiguous initial classification. However, an occasional cell shows excitation or inhibition to *two* separate spectral regions. Such cells were nonetheless included among the other opponent cells on the basis of the portion of the dual response which was maximal; for example, a cell which had its maximum response to the long wavelengths and a second, but smaller, excitatory response to a short-wavelength band would be considered a long-wavelength excitatory cell.

The question whether all the cells excited by long wavelengths and inhibited by short wavelengths are identical, and correspondingly for those excited by short wavelengths, is not a simple one to answer. Various measures of the cells' responses to flashes of monochromatic light usually give a continuous distribution of cells within either of these categories. Thus, the maximum firing rates of cells excited by long wavelengths are distributed over a range from 690 nm all the way to 560 nm; there is also a wide range of spectral points at which a cell's response crosses from excitation to inhibition. There is a correlation between a cell's spectral crosspoint and its point of maximum firing; thus, for a cell excited by long wavelengths, the longer the wavelength at which it crosses over, the longer is the wavelength at which its excitatory peak occurs. However, the crosspoints can generally be determined more reliably than the excitation peaks; a frequency distribution of crosspoints shows that there are no completely discrete types within the class of opponent cells excited by long wavelengths [see Fig. 4(a)]. But, as can also be seen from Fig. 4(a), the distribution is not unimodal, as might be expected if all were of a single type; rather, the distribution corresponds to what we might expect from two partially overlapping distributions.

The question of the number of types is important; however, arbitrary classification into different categories is not desirable. Suppose there is only one population of cells; by arbitrarily deciding (perhaps on the basis

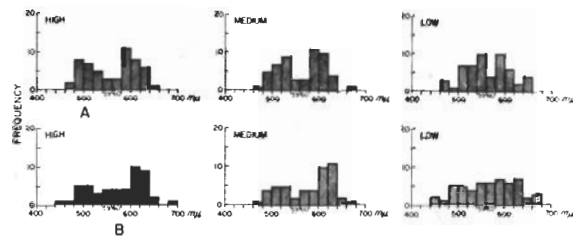

FIG. 4. Frequency distributions of the crosspoints from excitation to inhibition for high, medium, and low radiances (see text). A: Cells excited by long wavelengths and inhibited by short wavelengths. B: Cells excited by short wavelengths and inhibited by long wavelengths.

of a theory of color vision) that there should be two classes and lumping all cells with crosspoints above a certain point into one class and those below into another, the desired classification could be manufactured. This is in effect what many people, including ourselves, have done.⁴ On the other hand, it does not seem possible that there is an essentially unlimited number of different types of cells in terms of their spectral responses. There is strong psychophysical evidence in favor of a limited number of channels upon which color vision is based. If each cell concerned with color vision were transmitting information slightly different from every other cell, and if this information was maintained intact throughout later analyses, then two identical monochromatic lights lying side by side would never appear equal, since each would be affecting cells with slightly different responses. It is much more likely that, in the later neural analyses, information is averaged over a number of similar cells to determine color sensation, and that the slight quantitative differences among cells represent random variance in the system.

The statistical question was considered of what is the minimum number of independent normal distributions which best fits the distribution of crosspoints for the long-wavelength cells. The χ^2 test indicated that the hypotheses could not be accepted ($P < 0.05$) that the cells were drawn either from a single normally distributed population or from a square distribution. A good fit was obtained, however, by assuming that the crosspoints were drawn from two independent normal distributions of equal variance but with different means. On this ground, therefore, it is assumed that two separate types of cells are excited by long wavelengths. From this the working hypotheses were formulated that at some point in the visual system all of the cells of one type from a given retinal area are averaged to describe the quantity of one color parameter; that the cells of the other type are separately averaged to give the value of the other parameter; and that the two varieties are kept separate in their later projections to the cortex.

The same questions can be asked about cells excited by short wavelengths and inhibited by long wavelengths.

⁴ R. L. De Valois, C. J. Smith, and S. T. Kitai, *J. Comp. Physiol. Psychol.* **52**, 635 (1959).

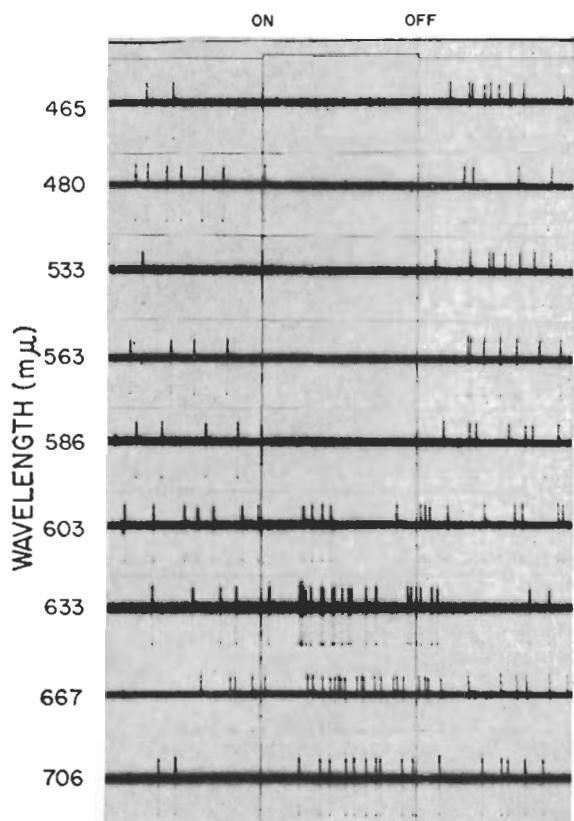

FIG. 5. Superimposed records of the responses of a +R-G cell to various wavelengths taken from an equal-energy spectrum. The one-second stimulus interval is indicated by the displacement in the trace at the top. This cell was chosen for reproduction because its firing rate at the different wavelengths corresponds closely to the average response rates for cells of this type.

Here, too, various measures were examined and again the crosspoints from excitation to inhibition were the most reliable. Fig. 4(b) shows the frequency histograms of the crosspoints of these cells. The presence of a bimodal distribution here is not as apparent as in the previous case. The observed distribution is significantly different (5% level) from a single normal distribution, but two normal distributions could not be fitted with the same confidence as before. We do not, therefore, have a definitive statistical basis for considering the short-wavelength cells to be of two separate types. This uncertainty was tentatively resolved by assuming that the cells excited by long and short wavelengths, respectively, are in fact mirror images of each other; all the cells excited by short wavelengths were then treated as if they were comparable to their opposite numbers. There is considerable evidence, some of which is described later, indicating that the two major classes of opponent cells (long- or short-wavelength excitatory) are put together from the same cone mechanisms and do form mirror images of each other. This provides some justification for the assumption noted above. The differences between the distributions of the crosspoints must then

be ascribed to random variance, but it should be emphasized that this is still tentative. The cutoff between the distributions of crosspoints was placed between 559 and 560 nm both for the cells excited by long wavelengths and for those excited by short wavelengths. For the former this is the most appropriate cut [see Fig. 4(a)], and on the basis of symmetry it was applied also to the latter. For example, applying this criterion to the cells excited by long wavelengths, all cells whose crosspoints for at least two of the three radiances tested, fell at or above 560 nm were classified as one type and the rest as another.

Opponent Cells—Examples of the Four Types

The above analysis produces four types of opponent cells. For convenience, these four types are designated as follows: Of the cells excited by long wavelengths there are those excited by red and inhibited by green (+R-G), and those excited by yellow and inhibited

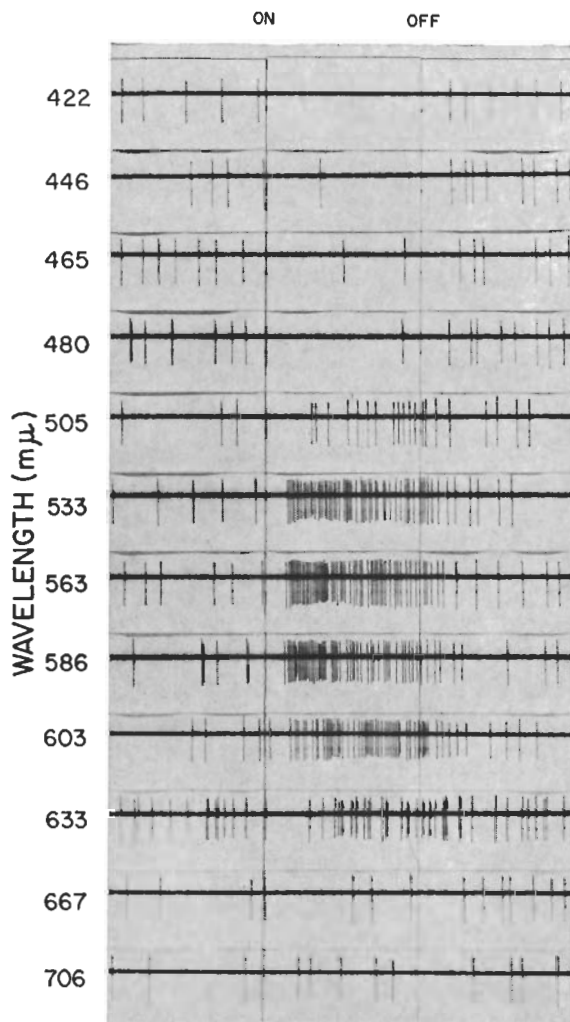

FIG. 6. Superimposed records from a +Y-B cell. Details as for Fig. 5.

by blue (+Y-B)—i.e., those with crosspoints above and below 559–560 nm, respectively. Of those cells excited by short wavelengths there are the green excitatory and red inhibitory (+G-R), and finally the blue excitatory and yellow inhibitory cells (+B-Y)—i.e., as before, those with crosspoints above or below 559–560 nm, respectively. The number of cells of each type is given in Fig. 3.

Figs. 5 through 8 show examples of cells of each of these opponent cell types. These are parallel records of the responses of a cell to a variety of different wavelengths at equal energy; the excitatory and inhibitory responses and the approximate wavelength at which the crossover from excitation to inhibition can be seen. It should also be emphasized that Figs. 5–8 are truly “typical” records: they were chosen not on aesthetic grounds but because they closely follow the mean values for each of the four types.

Figs. 9 through 12 show, for each of these four types

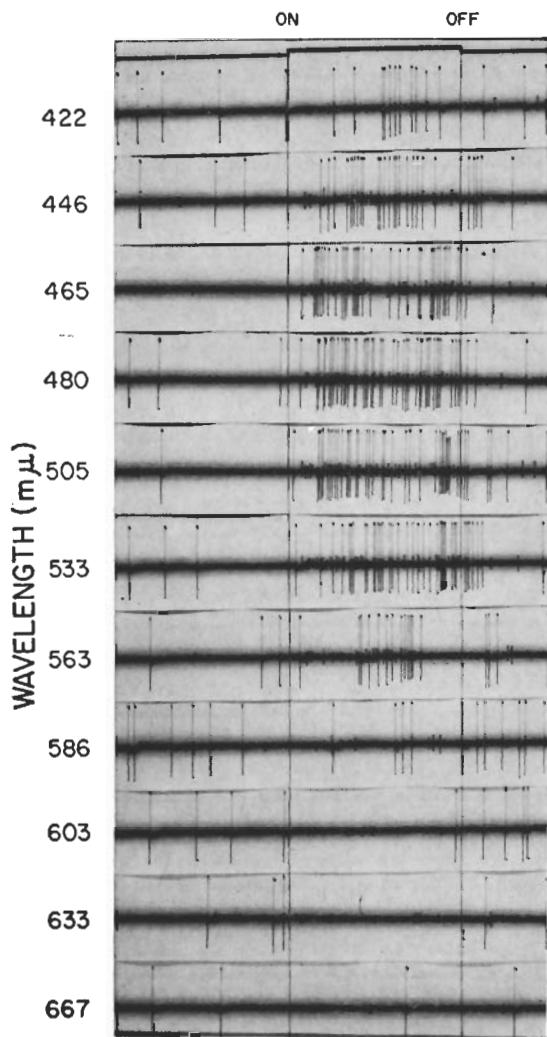

FIG. 7. Superimposed records from a +G-R cell. Details as for Fig. 5.

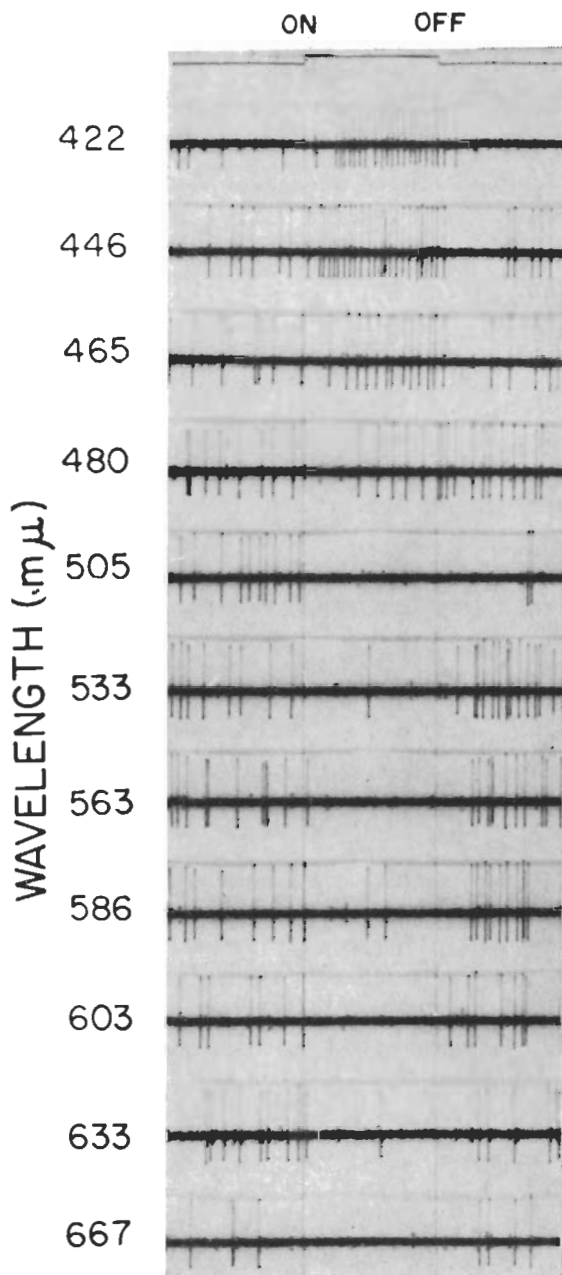

FIG. 8. Superimposed records from a +B-Y cell. Details as for Fig. 5.

of cells, the spectral response curves obtained by averaging the responses (see Procedure) of all similar cells at each of the three radiances (the numbers next to each curve are the mean log attenuation). In Fig. 9 the points at 706 nm were obtained from only six cells. The symbols and bars about each point represent plus and minus one-half the standard error of each mean. The spontaneous firing rates for the various cell types are fairly similar, about 5 to 7 spikes/sec.

Figure 9 demonstrates that the crosspoint from excitation to inhibition for the +R-G cells is at about

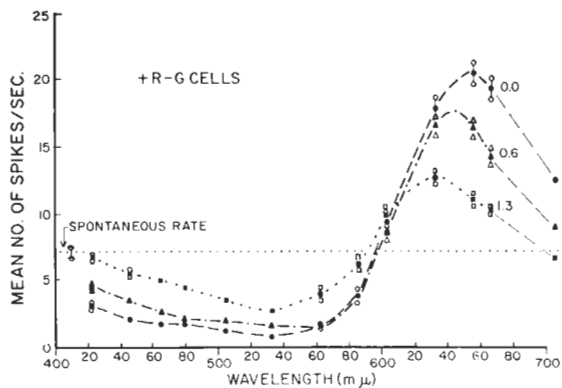

FIG. 9. Mean response curves for +R-G cells to an equal-energy spectrum. Numbers next to each curve represent log attenuation relative to maximum available. Open symbols and vertical lines at each point enclose one standard error of the mean. Dotted horizontal line gives, for this type, the mean firing rate in the absence of stimulation.

590 nm and does not change significantly with intensity. The points of maximum excitation and maximum inhibition, however, tend to shift systematically with an increase of radiance. At the low radiance, maximum firing was produced by light of approximately 630 nm; at a radiance 1.3 log units higher, the maximum shifted to 660 nm. The very short wavelengths produced more and more inhibition at higher radiances, while the region around 540 nm did not change greatly with radiance.

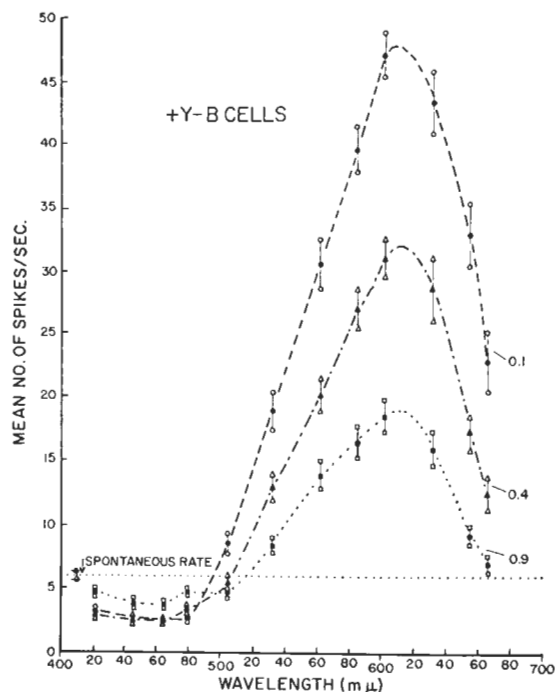

FIG. 10. Mean spectral response curves for +Y-B cells. Details as for Fig. 9.

In a paper published in 1961, De Valois and Jones⁵ had noted such a shift in point of maximum excitation; these data verify the shift, which appears to be related to the Bezold-Brücke effect. No similar shift in peak excitation is seen in the +Y-B cells (Fig. 10). The maximum firing of these cells is at 610 nm regardless of radiance. In the case of these +Y-B cells, the excitatory phase far outbalances the inhibitory phase, and the average firing rate is much higher than for the +R-G cells. At the highest radiance, +Y-B cells averaged close to 50 spikes/sec, as opposed to some 20 spikes/sec for the +R-G cells.

The +G-R cells (Fig. 11) also show more excitation than inhibition, but, as in the case of the +R-G cells, there is no shift in the crosspoints but a decided shift in the point of maximum excitation as intensity is changed. The average response curves of the +B-Y cells (Fig. 12) show a roughly balanced excitatory-inhibitory relationship, with some evidence for a change in crosspoint as radiance is changed, as was true for the +Y-B cells.

Opponent Cells—Spectral Sensitivities

The spectral sensitivity of each type of cell, given in Fig. 13, was computed from the data presented in Figs. 9 through 12. Some firing rate was chosen as a criterion and then the radiance required to produce the criterion firing rate was determined for each wavelength. This was done by plotting the mean responses of each type of cell at each wavelength as a function of log radiance; assuming that response, over a limited

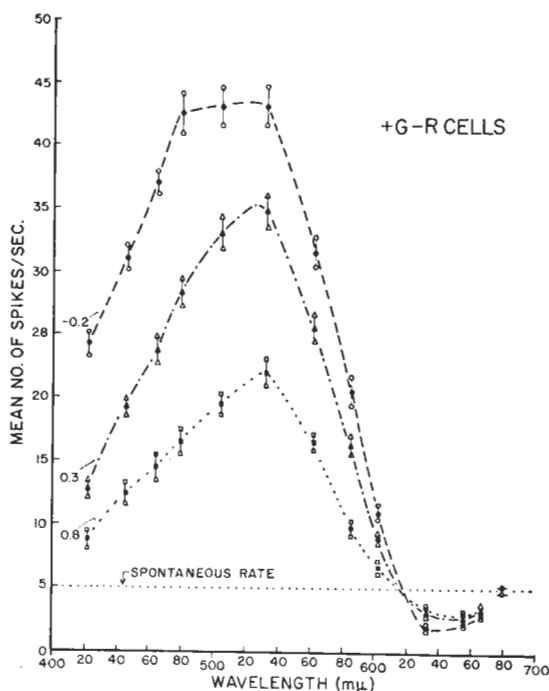

FIG. 11. Mean spectral response curves for +G-R cells. Details as for Fig. 9.

⁵ R. L. De Valois and A. E. Jones, in *The Visual System: Neurophysiology and Psychophysics*, R. Jung and H. Kornhuber, Eds. (Springer-Verlag, Berlin, 1961), pp. 178-191.

range, is a linear function of log radiance, the plotted values were fitted with a straight line. The radiance corresponding to the criterion response was found by interpolation. This was done for all of the wavelengths at which at least the criterion response was attained. The same procedure was carried out for the inhibitory responses. To see to what extent there is a shift of the spectral sensitivity with increased radiance, the spectral sensitivity curve was separately determined for several different criterion firing rates. The inhibitory spectral sensitivity curves could generally be obtained only for a single response criterion.

The shift in the peak sensitivity of the +R-G cells, and to some extent the +G-R cells, can be clearly seen in Fig. 13. The agreement between the peaks of the excitatory phase of the +R-G cells and the inhibitory phase of the +G-R cells is striking, as is the correspondence between the inhibitory peak of the +R-G cells and the excitatory peak of the +G-R cells. These two classes of cells thus appear to be mirror images of each other. The same is true in the case of the +Y-B and the +B-Y cells, which also are very close to being mirror images of each other. It was principally on these grounds that we felt justified in dividing the cells excited by short wavelengths into two categories using the same crosspoint cut as for the cells excited by long wavelengths, even though statistical confirmation of two distributions was lacking. Furthermore, we can demonstrate directly that cell types which are mirror images of each other (e.g., +R-G and +G-R) do in fact have underlying components of the same spectral sensitivity. If an intense chromatic adaptation light, with wavelength chosen so as to affect virtually only one of the underlying components (e.g., 650 nm), is used, one of either the excitatory or inhibitory phases is largely suppressed, allowing examination of the other phase by itself. Some of the results of such experiments have already been published by De Valois.⁶ Since such data are available for only a minority of the cells discussed here, suffice it to say that the results generally confirm the statements that +R-G and +G-R types

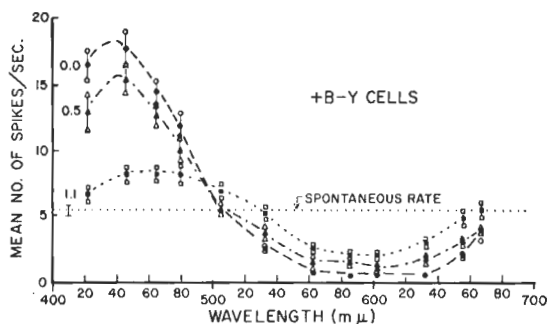

FIG. 12. Mean spectral response curves for +B-Y cells. Details as for Fig. 9.

⁶ R. L. De Valois, in *Contributions to Sensory Physiology*, W. D. Neff, Ed. (Academic Press Inc., New York, 1965), Vol. 1, p. 137.

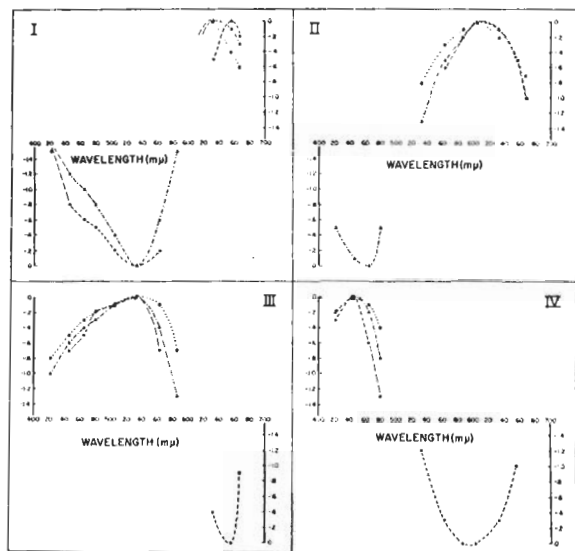

FIG. 13. Equal-response spectral sensitivity curves for the excitatory and inhibitory components of each of the four types of opponent cells. Ordinates are log relative radiance for criterion response. Curves above wavelength scales are for the excitatory portions; curves below wavelength scales are for the inhibitory portions. I: (+R-G) cells; criteria: excitation, \bullet 18 spikes/sec, Δ 15, \square 12; inhibition, \bullet 2, Δ 4. II: (+Y-B) cells; criteria: excitation, \bullet 30, Δ 25, \square 15; inhibition, \bullet 4, Δ 4. III: (+G-R) cells; criteria: excitation, \bullet 35, Δ 25, \square 15; inhibition, \bullet 3, Δ 3. IV: (+B-Y) cells; excitation, \bullet 15, Δ 12, \square 10; inhibition, \bullet 2. See text for description of methods used to determine these functions.

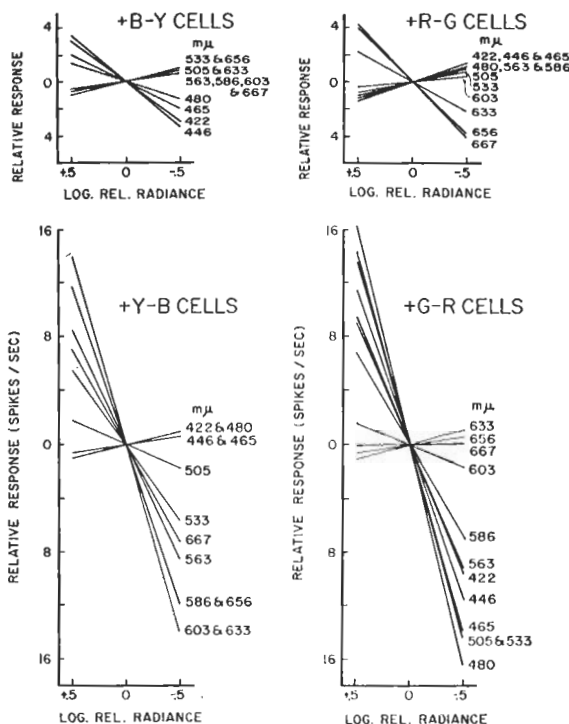

FIG. 14. Functions relating firing rate to radiance of monochromatic light. The functions for each of the four types of opponent cells are presented separately. All functions were arbitrarily equated at the middle one of the three radiances used.

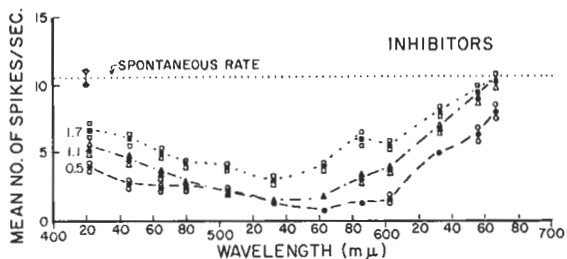

FIG. 15. Mean spectral response curves for nonopponent inhibitory cells. Details as for Fig. 9.

are mirror images, and similarly for +Y-B and +B-Y types.

The response rate of an opponent cell increases with increasing intensity of light of a wavelength which produces excitation. The slope of a plot of response rate against log intensity varies continuously, as a function of wavelength, as indeed it must since there are wavelengths which produce inhibition, at which wavelengths increasing the light intensity lowers the response rate, since it produces more inhibition. It is of interest to note in Fig. 14 that the slopes of the response-intensity functions vary from one type of cell to another. The +Y-B and +G-R cells have a very steep slope for those wavelengths producing excitation, whereas the +B-Y and +R-G cells never exhibit slopes as steep. This results in a different relationship among the different types of cells as intensity is changed. This is examined further in a later section.

Nonopponent Cells—Spectral Sensitivities

Figures 15 and 16 show the equal-energy response curves for the inhibitory and excitatory nonopponent cells. Since the entire response range of the inhibitory cells is only some eight spikes, and since variances are large, it was very difficult to determine reliably their

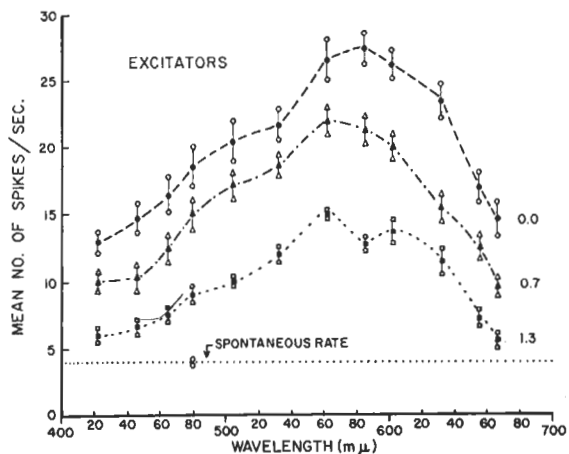

FIG. 16. Mean spectral response curves for nonopponent excitatory cells. Details as for Fig. 9.

spectral sensitivity; they are therefore excluded from further analysis. The data from the excitatory cells allow computation of their spectral sensitivity for a number of response criteria. This is shown in Fig. 17 for response criteria of 14 and 18 spikes/sec together with the CIE photopic luminosity function; the comparison is discussed in the next section.

(2) Comparisons with Psychophysical Data

As mentioned in the introduction, one of the principal questions of concern is how the dimensions of hue, saturation, and brightness are encoded in the visual system. It was suggested that this question might be answered by examining how these dimensions vary psychophysically with a parameter such as wavelength, and to compare against that the variation in firing rate of different types of cells. These comparisons are reported below.

Brightness

From the response curves of a class of cells, spectral sensitivity curves can be obtained by finding the intensity required for a certain criterion response. Correspondingly, in psychophysical experiments the luminance of different wavelengths required for equal brightness has been determined (the CIE photopic luminosity function). These two spectral sensitivity curves are compared to each other in Fig. 17, in which the spectral sensitivity of the nonopponent excitatory cells is plotted together with the CIE photopic luminosity function. The agreement is strikingly good over the range of 420 to 670 nm, the only significant deviation being an 0.3 log unit dip at about 530 nm. This excellent agreement provides strong support for the hypothesis that the nonopponent excitatory cells carry luminosity information.

A spectral sensitivity curve computed from the

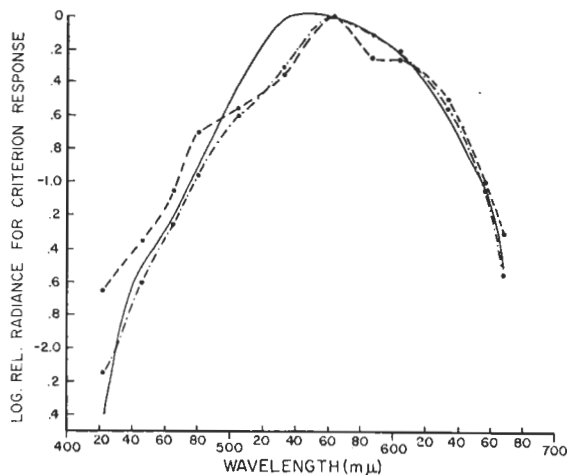

FIG. 17. Equal-response spectral sensitivity functions (response criteria: (●—●) 14 spikes/sec, (●- -●) 18 for nonopponent excitatory cells compared with the CIE photopic luminosity function (—○).

summed responses of all opponent cells regardless of types shows a much broader function (Fig. 18) than was found for the nonopponent cells. The opponent cells are far too sensitive to the extremes of the spectrum relative to the center to be transmitting luminosity information.

Saturation

Suppose that the opponent cells are carrying not brightness information, but color information. We might then expect that the differences between the responses of the opponent and nonopponent cells would reflect the extent to which different parts of the spectrum are colored, i.e., the saturation of different wavelengths. The middle of the spectrum, where both classes of cells are very responsive, thereby producing a lot of color activity and a lot of brightness activity, should be less saturated than the short or long wavelengths which evoke virtually no nonopponent-cell activity but still a moderate amount of opponent-cell activity. The prediction, therefore, is that the ratios of the sensitivities of the opponent and nonopponent cells should approximate the variation in saturation across the spectrum found in psychophysical experiments. (Hurwich and Jameson⁷ used a related approach in their analysis of psychophysical data.) This comparison is made in Fig. 19. The solid line is the difference between the log sensitivity of the opponent cells and the nonopponent excitators; the dotted line, with its ordinate on the right, is the average human saturation function taken from Wright.⁸ The two ordinates have been adjusted to make the curves coincide, so nothing can be said about the quantitative relationship between the two, but the qualitative agreement between the curves is striking.

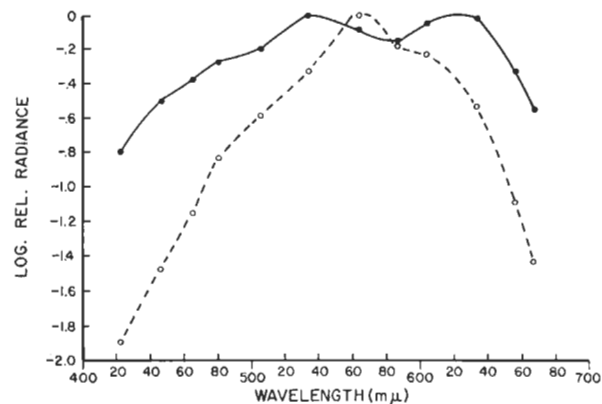

FIG. 18. Spectral sensitivity functions for nonopponent excitatory cells and for the entire sample of opponent cells. The curve for the excitators (○---○) is the average of the two curves in Fig. 17., while that for the opponent cells (●—●) was obtained by summing the responses of all opponent cells regardless of type, and then computing the function as for the nonopponent cells.

⁷ L. M. Hurwich, and D. Jameson, *Psychol. Rev.* 64, 384 (1957).

⁸ W. D. Wright, *Researches on Normal and Defective Colour Vision* (C. V. Mosby Co., St. Louis, 1947).

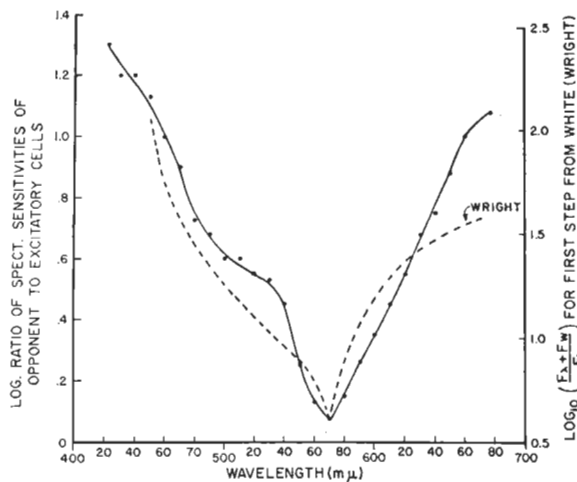

FIG. 19. The solid curve (ordinate on the left) shows the differences between the log spectral sensitivity for all the opponent cells and that for all the nonopponent excitatory cells—i.e., the differences between the curves in Fig. 18. The dashed curve (ordinate on the right) gives the saturation discrimination function for human observers (after Wright⁸).

Hue

If opponent cells convey color information and the four postulated types reflect a functional division, then we might expect correspondence between psychophysics and cell responses that depends directly on the differences among the four types—for the above section

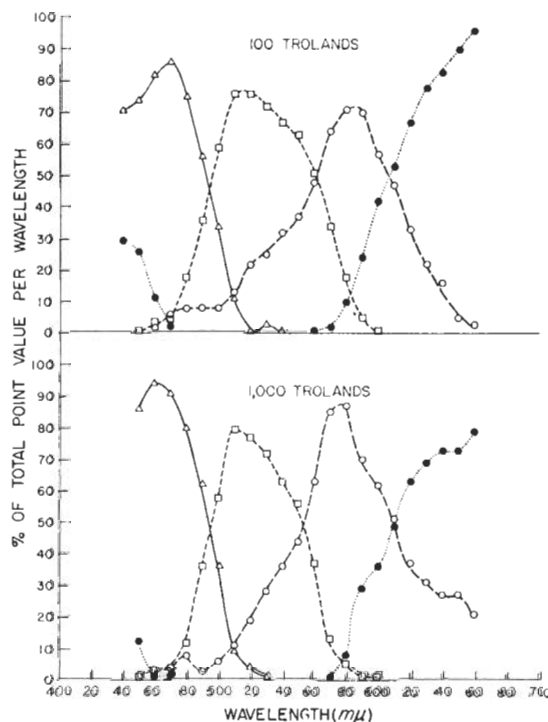

FIG. 20. Color naming as a function of wavelength. (Δ—Δ) blue, (□---□) green, (○—○) yellow, (●····●) red. Replotted after Boynton and Gordon.¹⁰ See text.

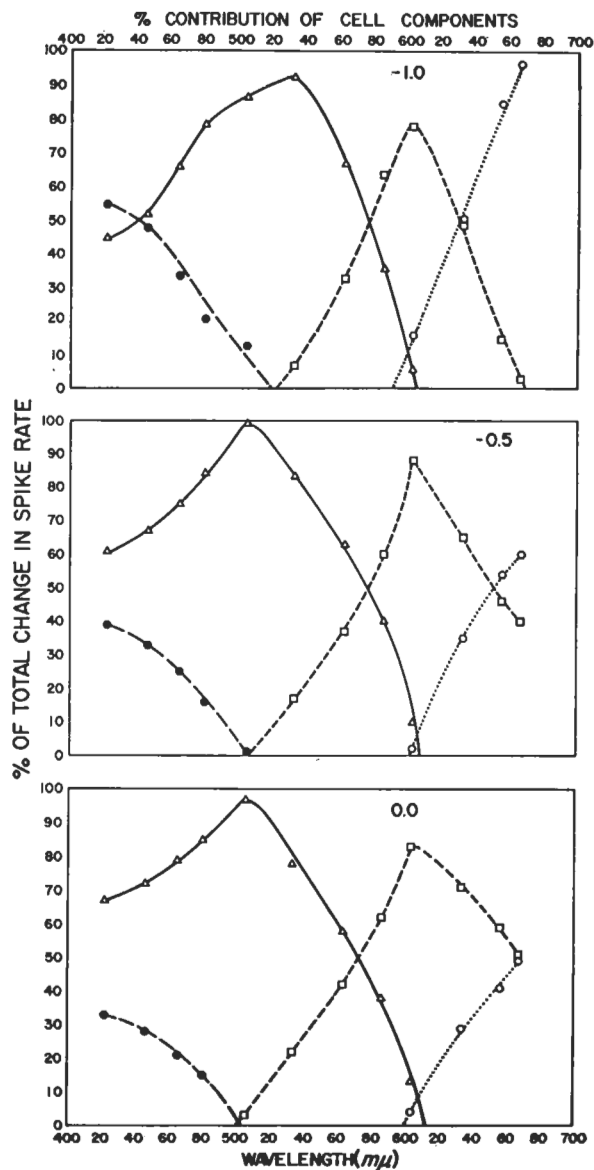

FIG. 21. Contributions, at three luminances half a log unit apart, the top graph being the lowest, of each of the four components underlying the responses of the opponent cells. ($\circ \cdots \circ$) $+R$ and $-R$, ($\square \cdots \square$) $+Y$ and $-Y$; ($\triangle \cdots \triangle$) $+G$ and $-G$, ($\bullet \cdots \bullet$) $+B$ and $-B$. See text for derivation of the components and method of computation.

on saturation it made no difference how many types of opponent cells were postulated. One possibility is the variation in hue of different parts of the spectrum. If hue is signalled by differences in response magnitudes among the various cell types, then those spectral regions which appear red should be those producing maximal responses in $+R-G$ cells, and so on. In effect, we propose an isomorphic relationship between the relative activity rates of the various cell types and the hue of a given light.

Qualitative attributes such as hue are not generally the subject matter of the psychophysics of color vision.

However, standard techniques are available for estimating qualitative variations and such scaling methods have been applied to hue in the recent color naming experiments of Beare in 1962,⁹ and Boynton and Gordon in 1965.¹⁰ In the latter experiment, subjects named the colors of light flashes presented in Maxwellian view, using one of four color names—red, yellow, green, and blue; they could further specify the color by use of another one of the same four names (e.g., yellow greenish). Responses to any one wavelength were then scaled by giving two points to the first response and one point to the second. The procedure was carried out at two luminances with a 10:1 ratio. We have averaged the data for their three subjects and then converted the scores to per cent of total number of points per wavelength; this is presented in Fig. 20.

Implicit in our derivation of four types of opponent cells was the assumption that they reflect real differences and that within a type any variations are random, the "true" picture being arrived at presumably by a cortical averaging process. It remains, therefore, to perform this averaging and compare the results with Fig. 20. However, this averaging can be done in several ways: All the responses (i.e., number of spikes during stimulus) to some light from cells of a given type can be counted (as in Figs. 9–12), or the responses can be considered as changes from a stable base line (i.e., average spontaneous firing rate). Since it is assumed that inhibition carries as much information as excitation, the latter course is the more appropriate. As discussed previously, it was also assumed that the same cone pigments underlie responses of "mirror image" types (e.g., $+R-G$ and $+G-R$); so it seems reasonable to say that excitation in one type ($+R-G$) carries the same information as inhibition in the other ($+G-R$). The absolute changes in response from the spontaneous firing rate were therefore added together to give the responses due to R, G, B, and Y components, respectively. The sums were expressed as percentages of the changes in all four types for a given light; to further facilitate comparison with Fig. 20 the responses so treated were values obtained by interpolation at exactly half log unit luminance increments on the functions relating response to log luminance (Fig. 14). The resulting curves are shown in Fig. 21.

In the region from 500–650 nm there is a strong resemblance between the data from our opponent cells in the macaque and the color-naming data from human observers. The long wavelengths beyond 600 nm are seen, at low luminance, as mainly red and a little yellow. In this region the major portions of the cells' responses are determined by the $+R$ and $-R$ components together with $+Y$ and $-Y$. The region around 580 nm is seen as yellow and here the contributions are about equal from $+R-R$ and $+Y-Y$ with some $+G-G$. Below 560 nm where the spectrum is seen as green the

⁹ A. C. Beare, *Am. J. Psychol.* **76**, 248 (1963).

¹⁰ R. M. Boynton and J. Gordon, *J. Opt. Soc. Am.* **55**, 78 (1965).

principal activity is in +G and -G components. Furthermore, changes in luminance produce the same shifts in the relative contributions of the cell components as in color names. Thus, at high luminances a larger region of the spectrum is seen as yellow and a similar change appears in Fig. 21. These changes in color with luminance are the Bezold-Brücke phenomenon; since corresponding changes occur in the cells' responses this further justifies the earlier assumption that opponent cells carry color information.

The good agreement between recording and psychophysical data breaks down at the short wavelengths. The region about 440 nm is clearly blue, yet the +B and -B components of the cells do not exceed the values for the green components in that region. This discrepancy may reflect the problems noted before in classifying the cells excited by the short wavelengths, or it may indicate that the blue system is amplified in its effect at some cortical level. Various color vision theorists such as Walraven¹¹ have speculated that at some point the chromatic effect of the blue system must be magnified considerably. If this is so, the present data suggest that the amplification occurs at the cortex.

It must be emphasized that the preceding discussion of R, G, B, and Y components underlying the opponent cells does not imply four different cone pigments. The spectral absorption characteristics of the macaque cone pigments have been delineated and it is clear that there are only three.¹ Rather, the discussion of four components indicates that the three cone types are linked in four basic patterns as seen at the LGN.

IV. SUMMARY AND CONCLUSIONS

The principal questions raised were how hue, saturation, and brightness are encoded in the primate visual

¹¹ P. L. Walraven, "On the Mechanisms of Colour Vision" (thesis, Univ. of Utrecht, 1962. Report of the Inst. for Perception RVO-TNO, 16, Soesterberg, Netherlands, 1962).

system. We believe that the analysis of the responses of the opponent and nonopponent cell classes provides some fairly clear answers to these basic questions. The brightness of a light is almost certainly encoded in the firing rate of the nonopponent cells; we have presented an analysis only of the nonopponent excitatory cells, but nonopponent inhibitors appear to give comparable information (this is clearly so for the squirrel monkey as shown by Jacobs¹²). The most compelling evidence that the nonopponent cells carry brightness information comes from the close agreement between the spectral sensitivity of the nonopponent excitators and the photopic luminosity function.

It was hypothesized that saturation is encoded in the relative responsiveness of opponent and nonopponent cells, saturated colors producing more opponent cell activity relative to nonopponent cell activity than unsaturated colors do. The similarity between saturation differences across the spectrum and the ratio of sensitivities of the opponent and nonopponent cells was presented as evidence for this.

Finally, evidence was presented that hue is encoded in the visual pathway by the relative activity rates of different types of opponent cells. There are grounds for dividing the opponent cells into four different types on the basis of the crosspoints from excitation to inhibition; cells of these different types respond preferentially to different spectral regions. The color seen in a given situation was shown to correspond, in the middle and long wavelengths, to those types most active in that situation. This relationship was found also to hold at different luminance levels: The difference in color of the spectrum at different luminances was shown to correspond to the change in relative responsiveness of the cells of different types.

¹² G. H. Jacobs, *Vision Res.* 4, 221 (1964).