

Module 16: Evaluating Vaccine Efficacy

Instructors:

Dean Follmann, Peter Gilbert, Erin Gabriel, Michael Sachs

Session 9: Introduction to Sieve Analysis of Pathogen Sequences, for Assessing How VE Depends on Pathogen Genomics– Part 2

Summer Institute in Statistics and Modeling in Infectious Diseases
University of Washington, Department of Biostatistics

Course materials at:

<http://faculty.washington.edu/peterg/SISMID2017.html>

July 24–26, 2017

Statistical Center for
HIV/AIDS Research & Prevention

SCHARP

FRED HUTCHINSON
CANCER RESEARCH CENTER

A LIFE OF SCIENCE

Outline of Session 9

1. Sieve Analysis Via Cumulative and Instantaneous VE Parameters
2. Cumulative VE Approach: NPMLE and TMLE
3. Mark-Specific Proportional Hazards Model
4. Example 1: RV144 HIV-1 Vaccine Efficacy Trial
5. **Example 2: RTS,S Malaria Vaccine Efficacy Trial**

RTS,S Malaria Sieve Analysis Core Team

Fred Hutchinson Cancer Research Center



Trevor Bedford

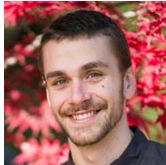

David Benkeser



Peter Gilbert



Michal Juraska

- Ted Holzman

Broad Institute of MIT and Harvard



Dan Neafsey



Dyann Wirth

- Karell Pellé, Clarissa Valim
- Allison Griggs, Bronwyn MacInnis

GlaxoSmithKline Vaccines



Marc Lievens

Path Malaria Vaccine Initiative



Chris Ockenhouse

RTS,S/AS01 Malaria Vaccine

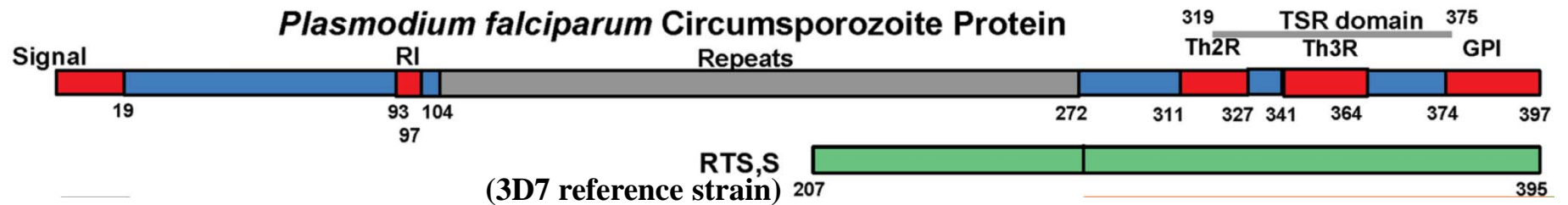

Plasmodium falciparum life cycle

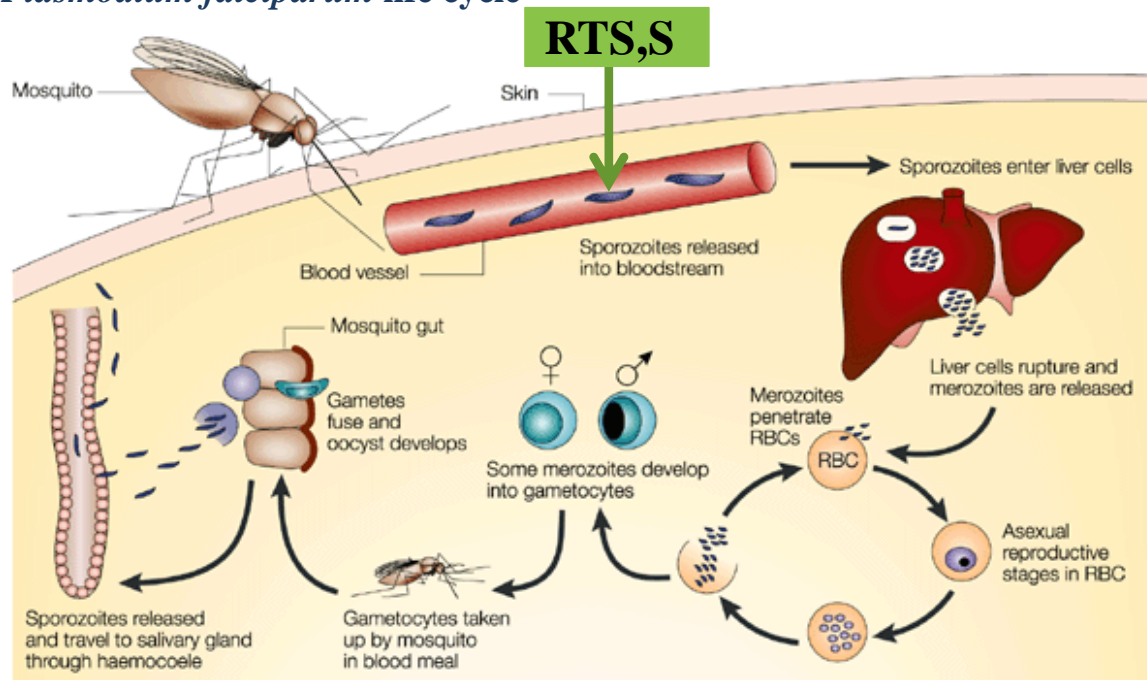

RTS,S/AS01 Phase 3 Vaccine Efficacy Trial

- Conducted by GSK and the PATH Malaria Vaccine Initiative at 11 sub-Saharan African sites between 2009-2014
- Two age cohorts:
 - 6,537 infants 6-12 weeks
 - 8,923 children 5-17 months

Study Sites

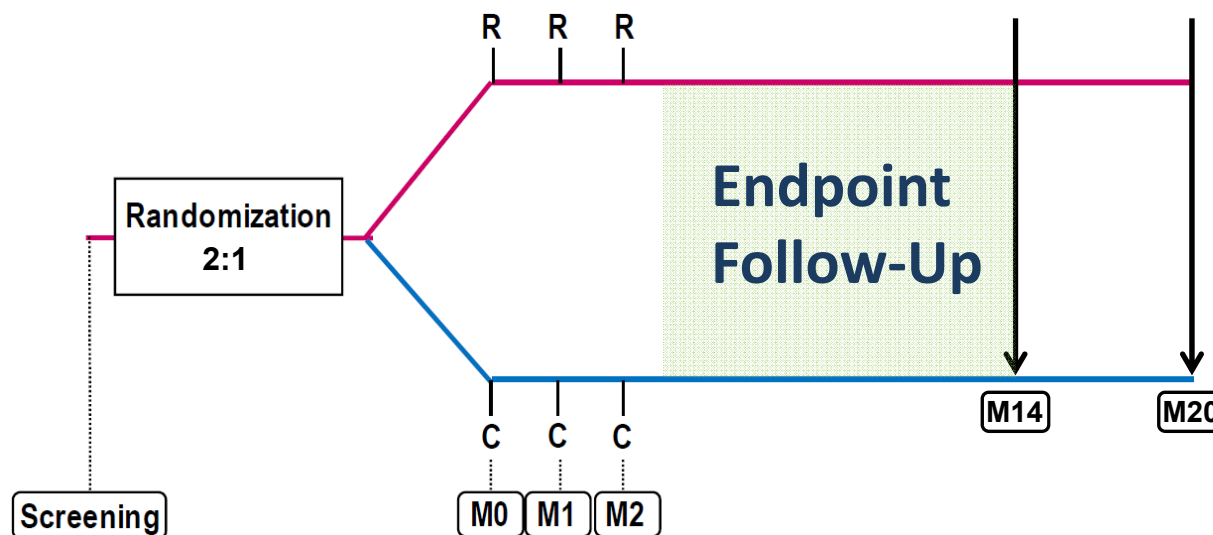
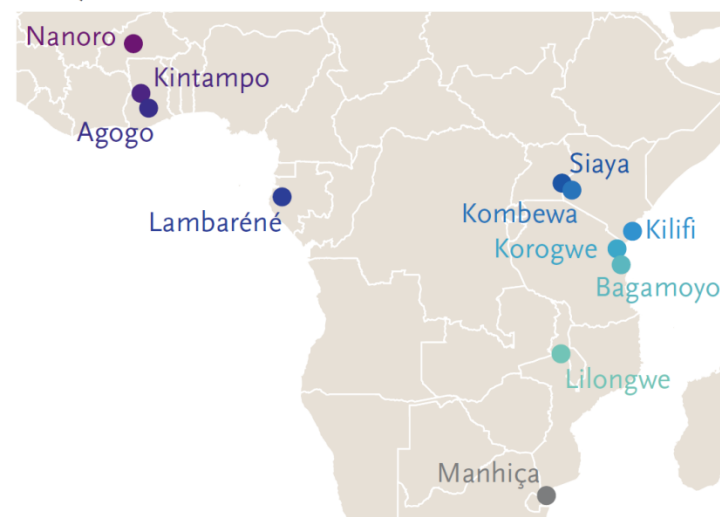

RTS,S/AS01 Vaccine Efficacy Trial Results

Infants aged 6-12 weeks

The NEW ENGLAND JOURNAL of MEDICINE

ORIGINAL ARTICLE

A Phase 3 Trial of RTS,S/AS01 Malaria Vaccine in African Infants

The RTS,S Clinical Trials Partnership

A Per-Protocol Population

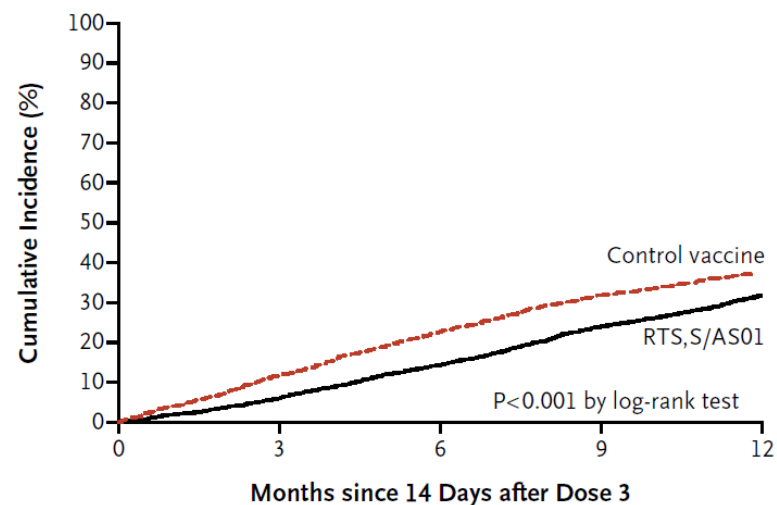

No. at Risk					
RTS,S/AS01	3995	3692	3309	2845	1272
Control vaccine	2008	1747	1501	1294	600

- N = 4358:2179 randomized to RTS,S: Control
- n = 1161:714 clinical malaria events
- **Est. VE* = 31% (97.5% CI, 24% to 38%)**

*Hazard-ratio based VE against clinical malaria during 12 months after vaccination in infants who received all 3 doses of vaccine according to protocol

RTS,S/AS01 Vaccine Efficacy Trial Results

Children aged 5-17 months



First Results of Phase 3 Trial of RTS,S/AS01 Malaria Vaccine in African Children

The RTS,S Clinical Trials Partnership*

A Per-Protocol Population

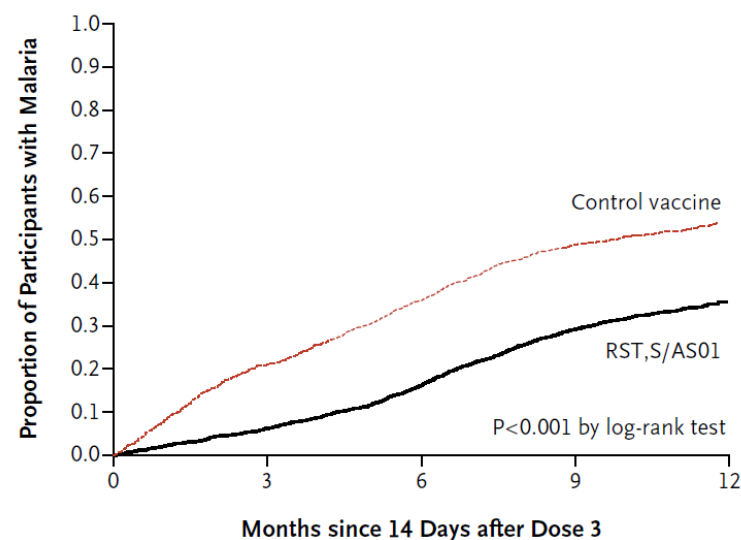

No. at Risk					
RTS,S/AS01	2830	2602	2279	1885	698
Control vaccine	1466	1137	909	712	274

- N = 3997:2003 randomized to RTS,S: Control
- n = 932:752 clinical malaria events
- **Est. VE* = 56% (97.5% CI, 51% to 60%)**

*Hazard-ratio based VE against clinical malaria during 12 months after vaccination in children who received all 3 doses of vaccine according to protocol

Instantaneous Vaccine Efficacy Wanes Over Time

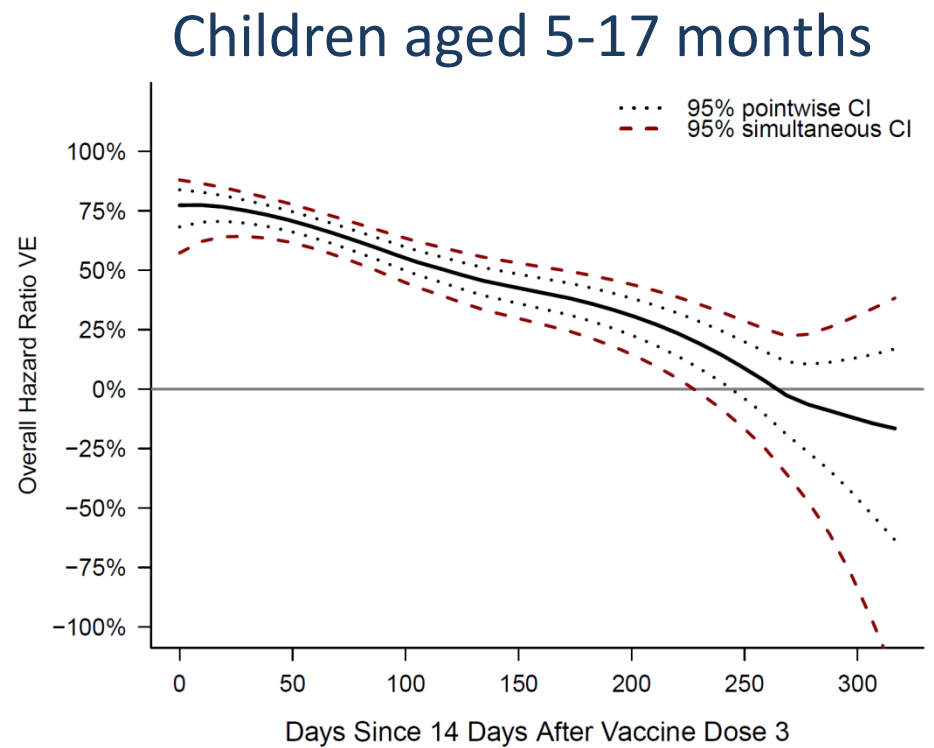
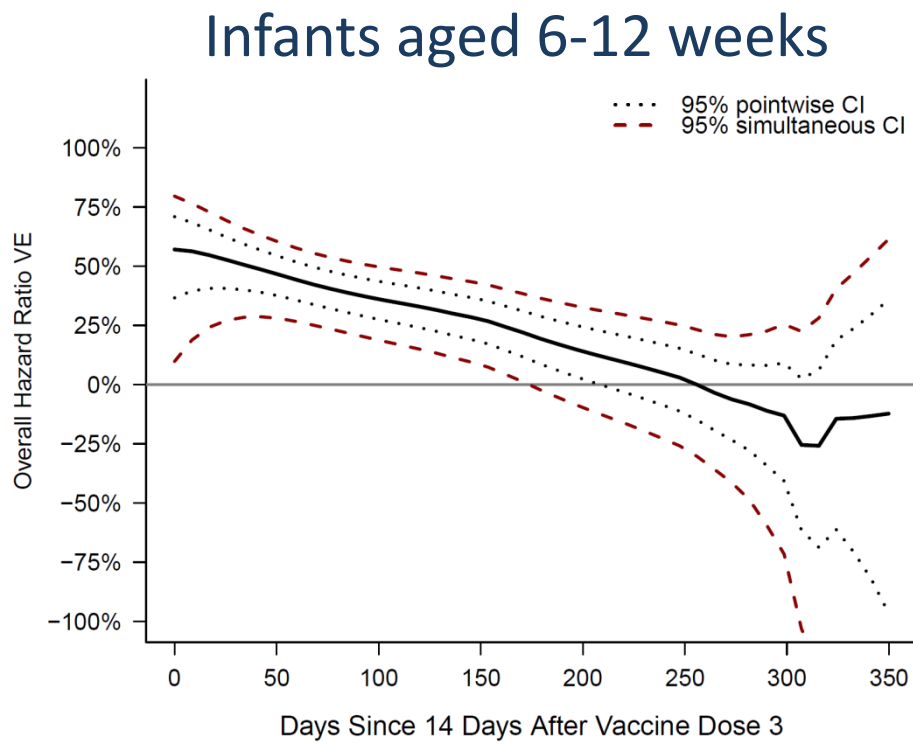

Sieve Analysis for Malaria

*Sporozoites inoculated
with mosquito bite*

*Sporozoites after
immune responses*

*Invade liver cells
& induce T cell responses*

*Infected erythrocytes
sampled for analysis*

NO IMMUNITY



NATURAL IMMUNITY



VACCINE-INDUCED IMMUNITY

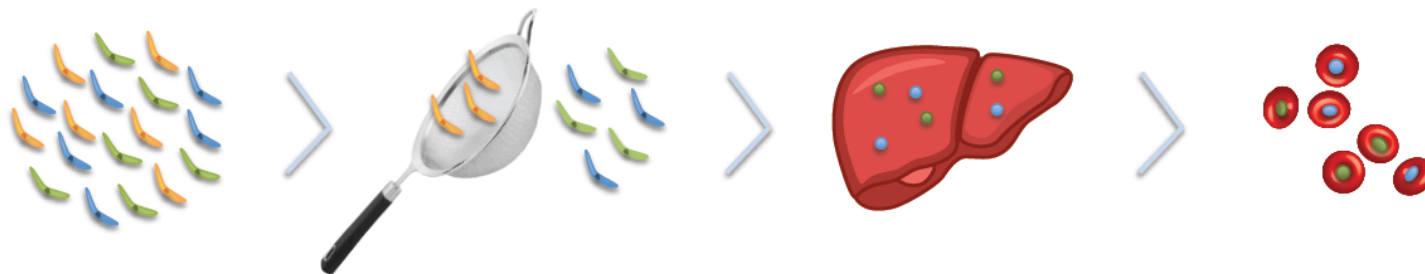

First RTS,S Sieve Analysis Results (Published October 21, 2015)

The NEW ENGLAND JOURNAL of MEDICINE

ORIGINAL ARTICLE

Genetic Diversity and Protective Efficacy of the RTS,S/AS01 Malaria Vaccine

D.E. Neafsey, M. Juraska, T. Bedford, D. Benkeser, C. Valim, A. Griggs, M. Lievens, S. Abdulla, S. Adjei, T. Agbenyega, S.T. Agnandji, P. Aide, S. Anderson, D. Ansong, J.J. Aponte, K.P. Asante, P. Bejon, A.J. Birkett, M. Bruls, K.M. Connolly, U. D'Alessandro, C. Dobaño, S. Gesase, B. Greenwood, J. Grimsby, H. Tinto, M.J. Hamel, I. Hoffman, P. Kamthunzi, S. Kariuki, P.G. Kremsner, A. Leach, B. Lell, N.J. Lennon, J. Lusingu, K. Marsh, F. Martinson, J.T. Molel, E.L. Moss, P. Njuguna, C.F. Ockenhouse, B. Ragama Ogutu, W. Otieno, L. Otieno, K. Otieno, S. Owusu-Agyei, D.J. Park, K. Pellé, D. Robbins, C. Russ, E.M. Ryan, J. Sacarlal, B. Sogoloff, H. Sorgho, M. Tanner, T. Theander, I. Valea, S.K. Volkman, Q. Yu, D. Lapierre, B.W. Birren, P.B. Gilbert, and D.F. Wirth



Analysis Cohort and Malaria Endpoint

- Per-protocol cohort
 - Received the Month 0, 1, 2 immunizations according to protocol
- Endpoint: Primary case definition of clinical malaria
 - First or only illness episode with a temperature of $\geq 37.5^{\circ}\text{C}$ and >5000 *P. falciparum* parasites per mm^3 or a severe malaria case
 - Count endpoints 14–385 days post immunizations

Sequencing of Malaria Endpoints [Broad Institute]

- CS C-terminus and SERA2 control amplicons sequenced with Illumina MiSeq
- All sequence data screened for random and systematic errors using validated pipelines
- After error filtration:
 - 4,421 samples for the CS C-terminus amplicon
 - 4,499 samples for the SERA2 amplicon

Structuring Parasite Genomic Variation

- Summarize genomic features of a given founder malaria parasite by:
 - Perfect vaccine haplotype (3D7) match or mismatch (binary feature)
- Applied for 6 regions and 42 individual AA positions
 - Full SERA2 amplicon, full CS C-terminus amplicon
 - 4 haplotype regions in CS C-terminus: Th2R, Th3R, DV10, LD*
 - Polymorphic AA positions in the CS C-terminus (25 AA positions) and in SERA2 (17 AA positions)

* AA positions 314, 317, 352, 354, 356, 357

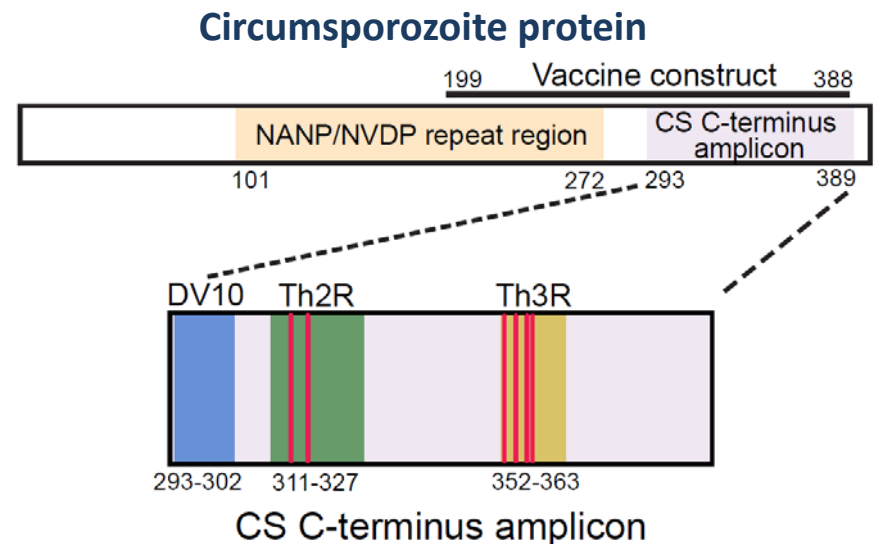

- Genomic feature definitions finalized prior to sieve analysis based on treatment-blinded descriptive analysis of the malaria genomic data

Statistical Assessment of 3D7 Match vs. Mismatch Sieve Effects

Applied cumulative and prop. hazards VE methods

- Estimate $VE^{cum/disc}(t, j)$ for $j=(\text{match}, \text{mismatch})$
t through Month 14
- Test
 $H_0: VE^{cum/disc}(t=14 \text{ mo}, j=\text{match}) = VE^{cum/disc}(t=14 \text{ mo}, j=\text{mismatch})$

Aalen-Johansen NPMLE and TMLE (Benkeser, Carone, Gilbert, 2016)

- Estimate $VE^{haz/disc}(j)$ for $j=(\text{match}, \text{mismatch})$
t through Month 14
- Test

$$H_0: VE^{haz/disc}(j=\text{match}) = VE^{cum/disc}(j=\text{mismatch})$$

Cox model and Lunn and McNeil (1995, *Biometrics*) test

Complexity of Infection (COI)

- Approximately 70% of cases are complex, with multiple founder haplotypes
- Sieve analyses are done on datasets with one founder haplotype randomly sampled from each case with $COI \geq 2$
- The VE parameters are interpretable under the assumption that each founder is an independent mosquito transmission event
- Multiple outputation (Follmann, 2003, *Biometrics*) is used to obtain a valid/unbiased analysis
 - Repeat the sieve analysis for a large number of sampled datasets with one founder per case, average results to obtain overall results
 - For each analysis, the number of multiple outputations is selected to make the results very similar to what would be obtained with exhaustive multiple outputation

Approach to Multiplicity of Sieve Effect Tests

- Multiplicity adjustment for the sieve effect p-values separately for the 2 age categories, the 2 proteins (CS, SERA2), the 2 endpoints, and the 2 VE parameters
- Holm-Bonferroni adjusted p-values and q-values
- Statistically significant sieve effect defined as $q \leq 0.20$ for multiply compared loci and as unadjusted $p \leq 0.05$ for the full amplicon analysis

Greater Numbers of **Clinical Malaria 3D7** Mismatches in RTS,S Recipients

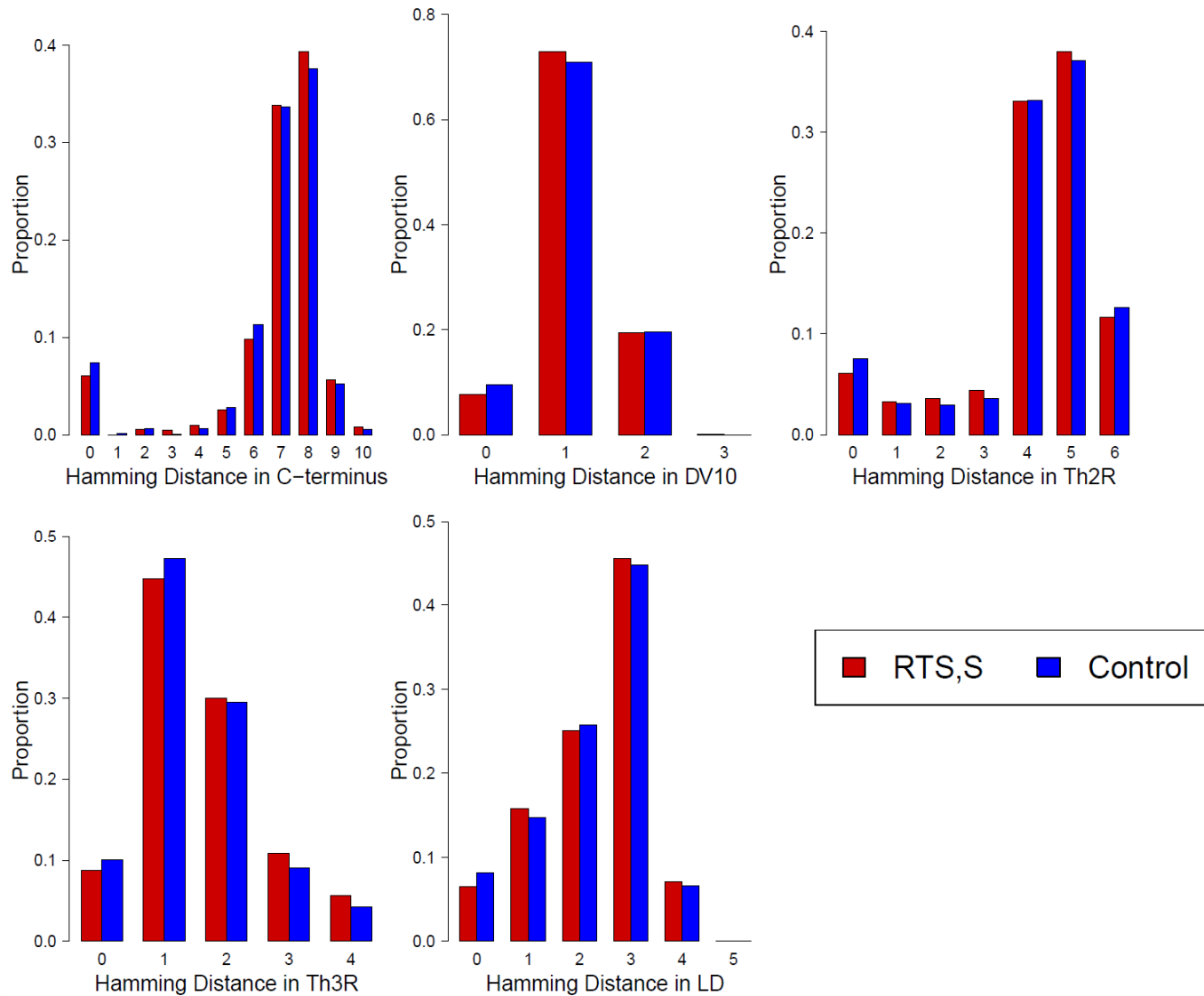

Per-Protocol Category of 5-17 Month Olds: Clinical Malaria Endpoint

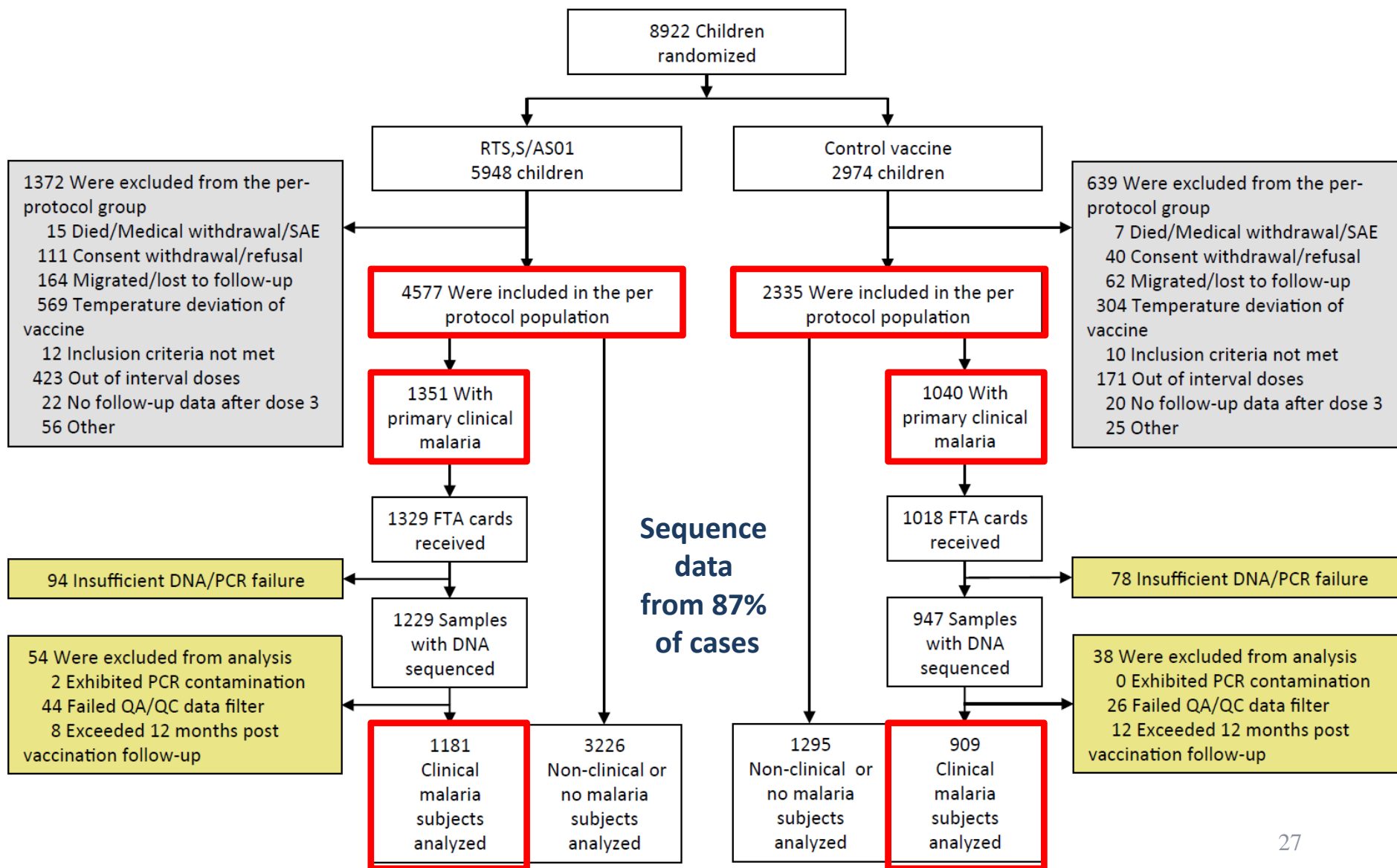

COI and CS C-Terminus 3D7-Matched Frequencies of Clinical Malaria Endpoint

Fig. 3 from Neafsey et al. (2015)

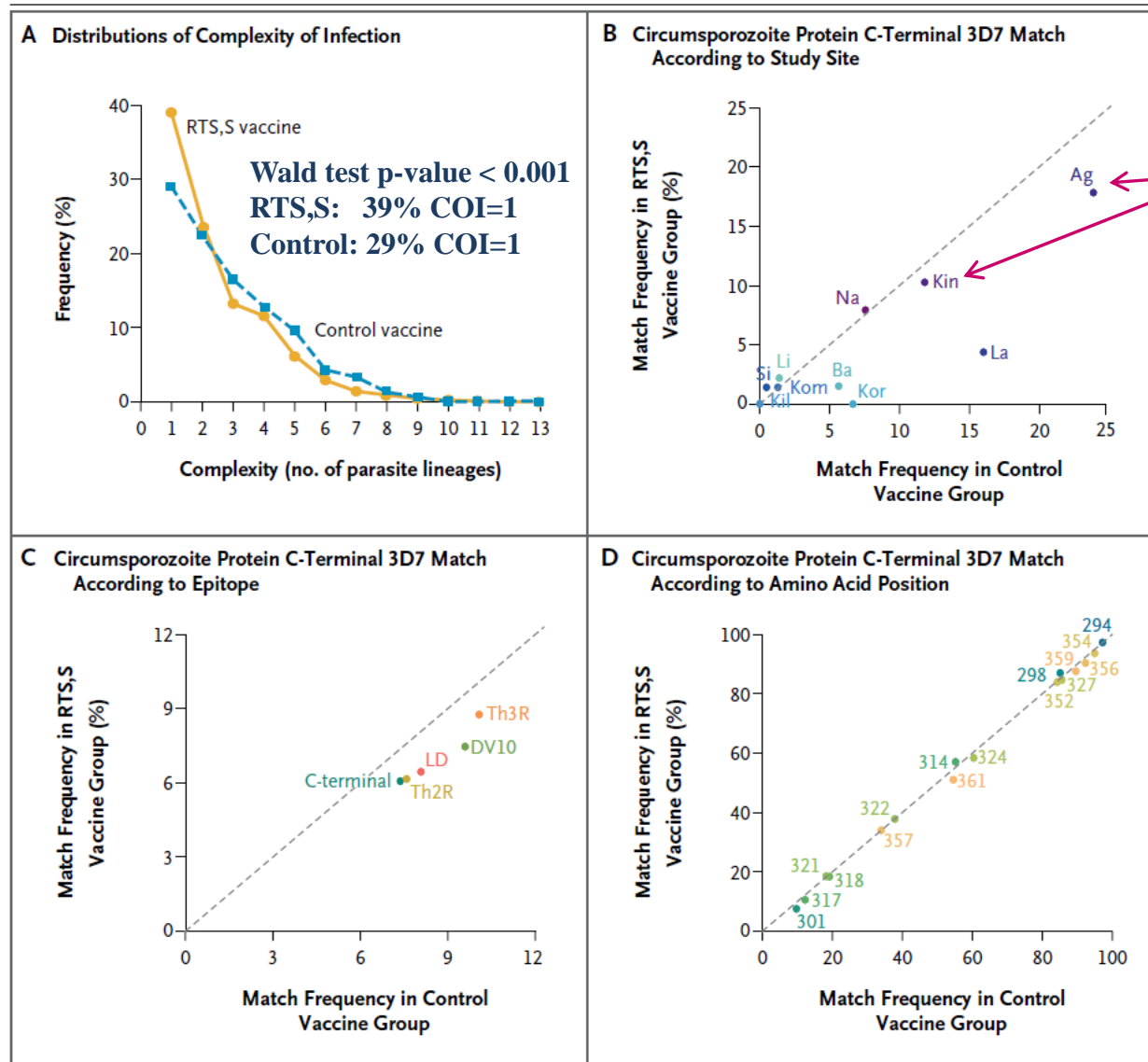

These descriptive differences correspond to a significant sieve effect

No Sieve Effects in the SERA2 Control Protein

- No evidence for vaccine sieve effects in SERA2
 - 36 hypothesis tests (SERA2 full amplicon, 17 AA sites) × (Cumulative VE, Prop hazards VE):
 - P-values ~ uniformly distributed
 - All unadjusted p-values ≥ 0.05

CS C-Terminus Sieve Effect: Cumulative VE 50% vs. 33%; Hazard Ratio VE 63% vs. 54%

Fig. 4 from Neafsey et al. (2015)

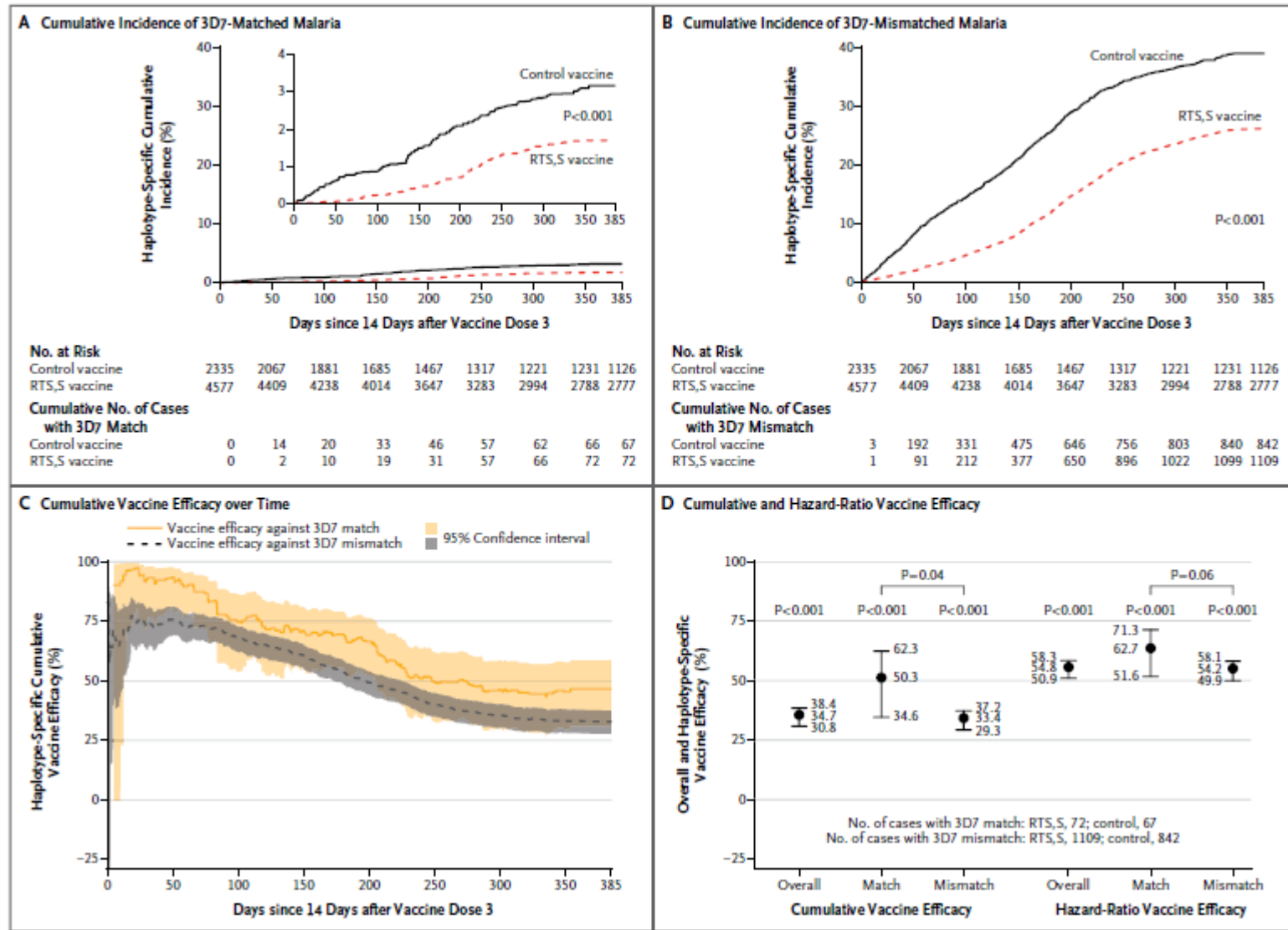

CS C-Terminus Sieve Effect: Cumulative VE 50% vs. 33%; Hazard Ratio VE 63% vs. 54%

Fig. 4 from Neafsey et al. (2015)

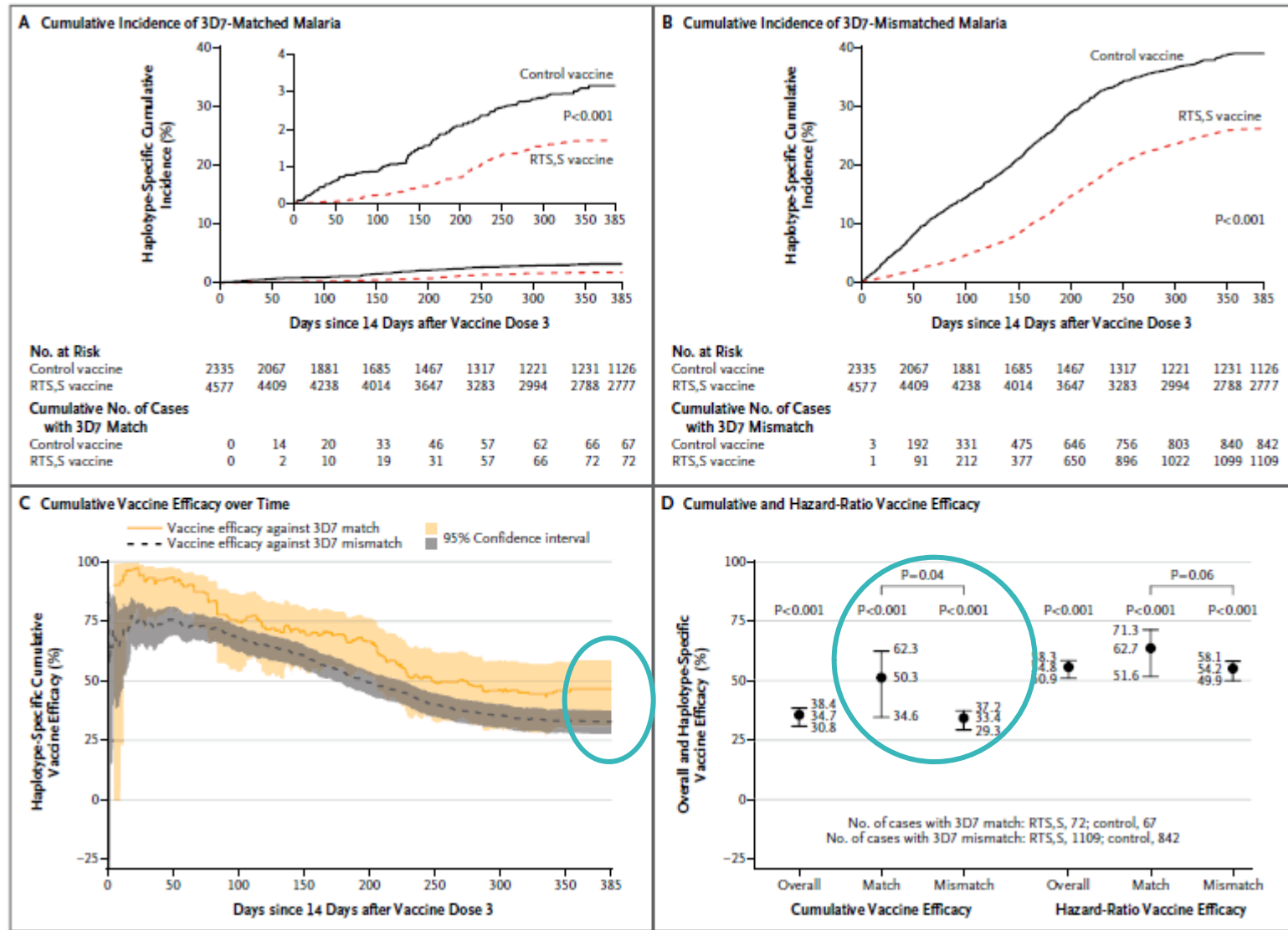

CS C-Terminus Sieve Effect: Cumulative VE 50% vs. 33%; Hazard Ratio VE 63% vs. 54%

Fig. 4 from Neafsey et al. (2015)

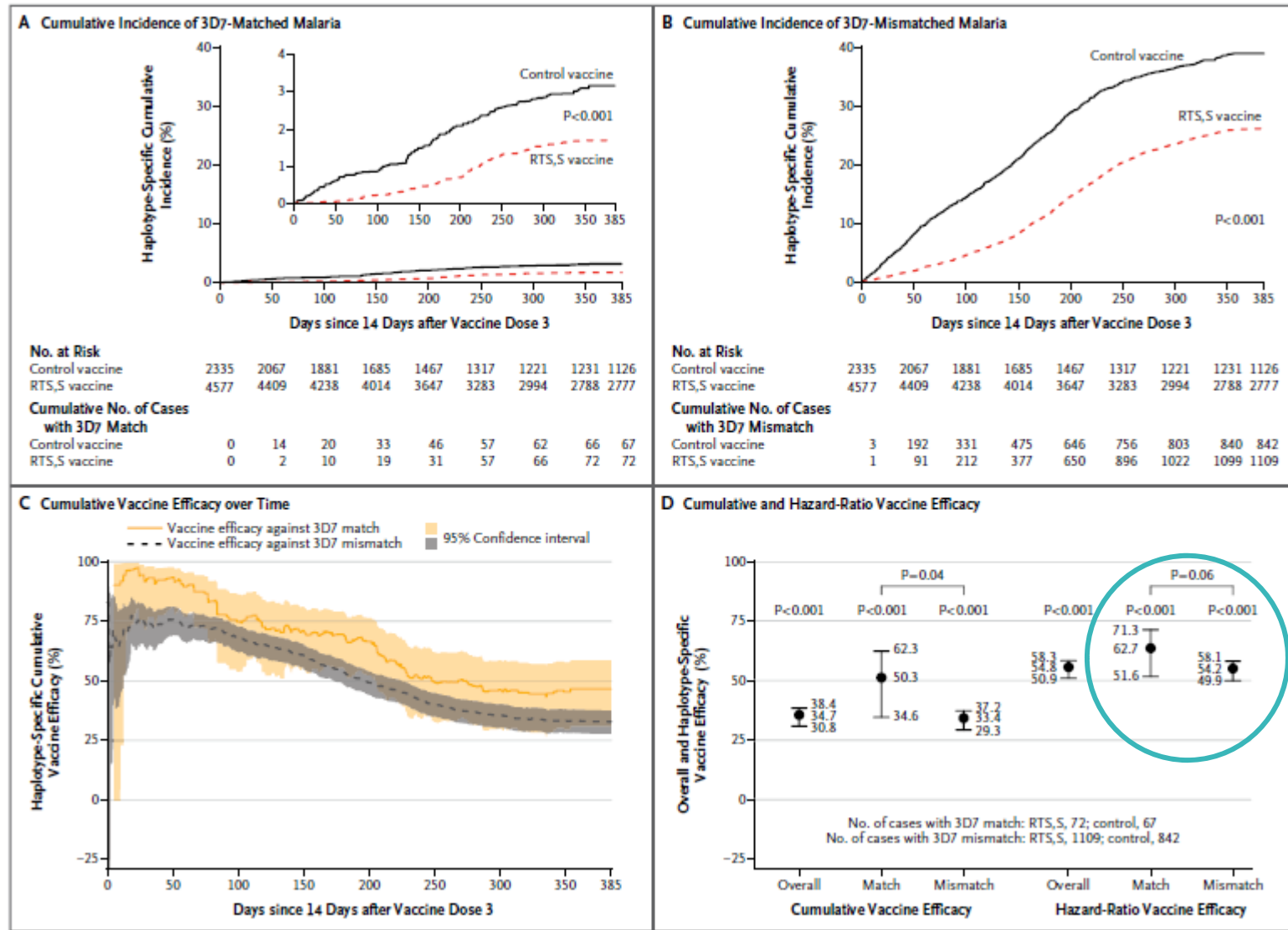

4 CS C-Terminus Haplotype Regions: Consistent Sieve Effects (Cum. VE 50% vs. 33%; HR VE 63% vs. 54%)

A. Cumulative Vaccine Efficacy

Haplotype Locus	RTS,S Match/ Mismatch	No. of Events (Cum. Incidence)		Haplotype-Specific Efficacy ^a			Differential Efficacy FWER P-value	P-value	Q-value
		RTS,S Vaccine	Control Vaccine	VE (%)	95% CI	P-value			
CS C-Terminus	Match	72 (1.7%)	67 (3.2%)	50.3	(34.6, 62.3)	<0.001	0.04*	-	-
CS C-Terminus	Mismatch	1109 (26.2%)	842 (39.0%)	33.4	(29.3, 37.2)	<0.001			
DV10	Match	90 (2.1%)	86 (4.0%)	50.2	(36.4, 61.0)	<0.001	0.02	0.61	0.15*
DV10	Mismatch	1091 (25.7%)	822 (38.1%)	33.0	(28.8, 36.9)	<0.001			
LD ^b	Match	77 (1.8%)	74 (3.5%)	51.0	(36.3, 62.4)	<0.001	0.03	0.66	0.15*
LD	Mismatch	1104 (26.1%)	834 (38.6%)	33.1	(29.0, 37.0)	<0.001			
Th2R	Match	72 (1.7%)	68 (3.2%)	50.7	(35.3, 62.4)	<0.001	0.03	0.81	0.15*
Th2R	Mismatch	1109 (26.2%)	840 (38.9%)	33.3	(29.2, 37.2)	<0.001			
Th3R	Match	103 (2.4%)	91 (4.3%)	46.4	(32.4, 57.5)	<0.001	0.08	1.00	0.20*
Th3R	Mismatch	1078 (25.4%)	817 (37.8%)	33.3	(29.1, 37.2)	<0.001			

Fig. 5 from Neafsey et al. (2015)

B. Hazard Ratio Vaccine Efficacy

Haplotype Locus	RTS,S Match/ Mismatch	No. of Events (Incidence)		Haplotype-Specific Efficacy ^a			Differential Efficacy FWER P-value	P-value	Q-value
		RTS,S Vaccine	Control Vaccine	VE (%)	95% CI	P-value			
CS C-Terminus	Match	72 (2.0%)	67 (4.4%)	62.7	(51.6, 71.3)	<0.001	0.06	-	-
CS C-Terminus	Mismatch	1109 (31.4%)	842 (55.0%)	54.2	(49.9, 58.1)	<0.001			
DV10	Match	90 (2.5%)	86 (5.6%)	63.1	(53.0, 71.0)	<0.001	0.04	1.00	0.31
DV10	Mismatch	1091 (30.8%)	822 (53.7%)	53.9	(49.6, 57.8)	<0.001			
LD ^b	Match	77 (2.2%)	74 (4.8%)	63.7	(53.0, 71.9)	<0.001	0.04	1.00	0.31
LD	Mismatch	1104 (31.2%)	834 (54.5%)	54.0	(49.7, 57.9)	<0.001			
Th2R	Match	72 (2.0%)	68 (4.4%)	63.4	(52.5, 71.8)	<0.001	0.03	0.91	0.31
Th2R	Mismatch	1109 (31.4%)	840 (54.9%)	54.1	(49.8, 58.0)	<0.001			
Th3R	Match	103 (2.9%)	91 (5.9%)	61.1	(50.9, 69.1)	<0.001	0.17	1.00	0.67
Th3R	Mismatch	1078 (30.5%)	817 (53.4%)	54.0	(49.7, 58.0)	<0.001			

20 40 60 80
V/F (%)

20 40 60 80
VE (%)

CS C-Terminus AA Site-Scanning: 7 Sites with $VE(\text{Match}) > VE(\text{Mismatch})$ [q-value < 0.20]

Table 1 from Neafsey et al. (2015)

Cumulative VE sieve analysis

Amino Acid Position [†]	Haplotype-Matched Efficacy [†]			Haplotype-Mismatched Efficacy [†]			Differential Efficacy		
	VE (%)	95% CI	P-value	VE (%)	95% CI	P-value	P-value	FWER P-value	Q-value
DV10									
294	34.8	(30.8, 38.6)	< 0.001	31.3	(-6.4, 55.6)	0.09	0.83	1.00	0.89
295	34.9	(31.0, 38.6)	< 0.001	12.6	(-78.8, 57.2)	0.71	0.44	1.00	0.71
296	34.8	(30.9, 38.5)	< 0.001	7.1	(-310.9, 79.0)	0.92	0.67	1.00	0.89
298	33.5	(29.1, 37.7)	< 0.001	41.7	(30.1, 51.4)	< 0.001	0.20	1.00	0.41
299*	35.4	(31.5, 39.1)	< 0.001	-62.8	(-186.0, 7.3)	0.09	0.003	0.08	0.08
301*	49.2	(35.3, 60.1)	< 0.001	33.1	(28.9, 37.0)	< 0.001	0.03	0.81	0.15
302	34.8	(30.9, 38.5)	< 0.001	20.0	(-108.2, 69.3)	0.64	0.69	1.00	0.89
303	34.6	(30.7, 38.3)	< 0.001	68.4	(-100.9, 95.0)	0.22	0.45	1.00	0.71
Th2R									
314 ^{LD}	32.7	(26.6, 38.2)	< 0.001	37.3	(30.9, 43.0)	< 0.001	0.33	1.00	0.61
317 ^{LD*}	45.9	(33.3, 56.2)	< 0.001	33.1	(28.9, 37.1)	< 0.001	0.06	1.00	0.19
318	36.9	(25.8, 46.4)	< 0.001	34.2	(29.8, 38.4)	< 0.001	0.65	1.00	0.89
320	34.4	(30.4, 38.1)	< 0.001	64.0	(21.0, 83.6)	0.01	0.14	1.00	0.32
321	35.7	(24.3, 45.3)	< 0.001	34.5	(30.1, 38.7)	< 0.001	0.85	1.00	0.89
322	34.8	(27.2, 41.5)	< 0.001	34.7	(29.4, 39.6)	< 0.001	0.99	1.00	0.99
324	37.3	(32.0, 42.2)	< 0.001	30.7	(23.3, 37.4)	< 0.001	0.16	1.00	0.35
327	35.5	(31.2, 39.5)	< 0.001	30.1	(16.5, 41.4)	< 0.001	0.42	1.00	0.71
Th3R									
349	34.8	(30.9, 38.5)	< 0.001	25.4	(-84.1, 69.8)	0.53	0.81	1.00	0.89
352 ^{LD}	35.1	(30.7, 39.2)	< 0.001	32.8	(20.0, 43.5)	< 0.001	0.73	1.00	0.89
354 ^{LD*}	36.0	(32.0, 39.8)	< 0.001	10.8	(-22.6, 35.1)	0.48	0.05	1.00	0.17
355	34.7	(30.8, 38.4)	< 0.001	54.1	(-286.1, 94.5)	0.47	0.71	1.00	0.89
356 ^{LD*}	36.2	(32.2, 40.1)	< 0.001	15.8	(-7.8, 34.3)	0.17	0.04	0.85	0.15
357 ^{LD}	35.3	(27.3, 42.5)	< 0.001	34.4	(29.3, 39.2)	< 0.001	0.86	1.00	0.89
359*	36.1	(32.0, 40.1)	< 0.001	22.2	(5.2, 36.2)	0.01	0.07	1.00	0.20
361*	39.3	(33.6, 44.4)	< 0.001	29.3	(22.4, 35.5)	< 0.001	0.03	0.81	0.15

CI denotes confidence interval, and FWER p-value adjusted²⁸ p-value controlling the familywise error rate.

AA Positions in the CS C-Terminus Are Independent or Very Weakly Correlated:

- Median correlation r between pairs of the 7 signature sites = 0.05
IQR = -0.02–0.19

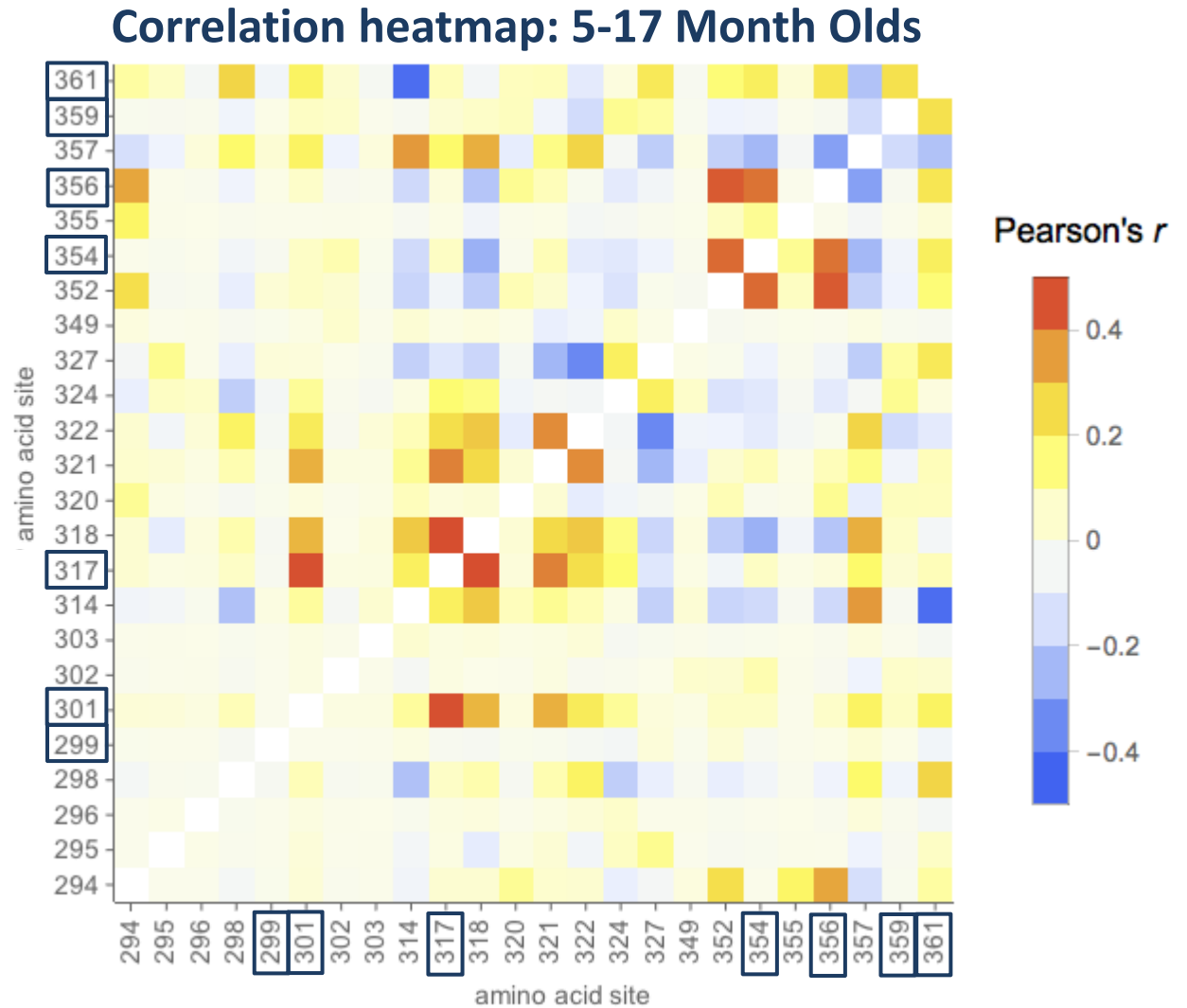

Trend Toward Decreasing Cumulative VE with the Number of 3D7 Mismatching Signature Positions

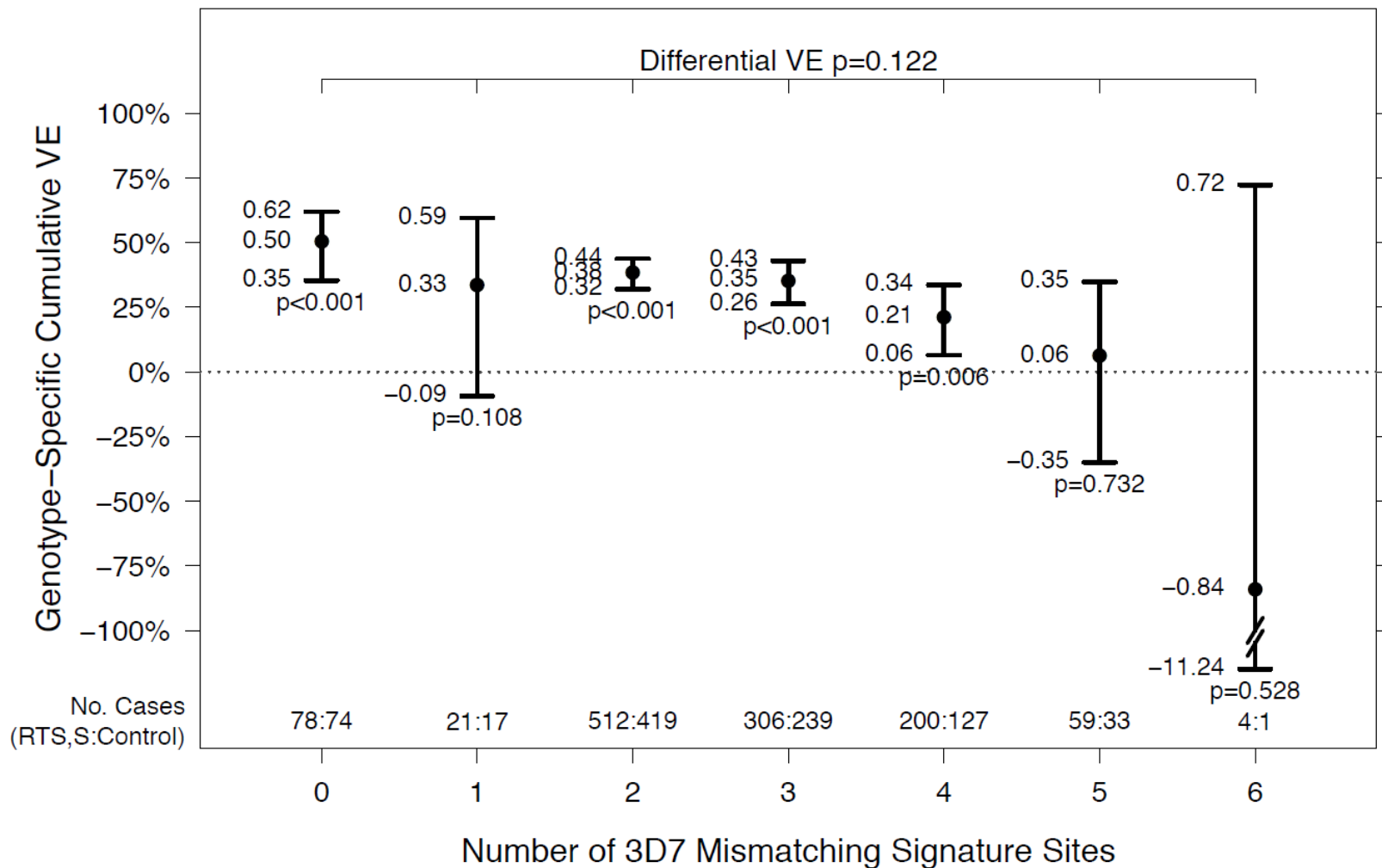

Summary (1): No Sieve Effects at Control Protein SERA2 for Either Age Cohort

- Clear lack of evidence for a vaccine sieve effect in SERA2 for both 6–12 week olds and 5–17 month olds
 - This result fit expectations given SERA2 is not in the RTS,S vaccine and the lack of expected cross-creativity

Summary (2): No Sieve Effects in Any Sense for 6–12 Week Olds

- COI distribution similar vaccine vs. control
- VE similar for 3D7 matched and 3D7 mismatched malaria for match in the CS C-terminus defined by:
 - Full amplicon, 4 haplotype regions, 25 AA sites

Summary (3): Sieve Effects at CS C-Terminus and NANP/NVDP Repeats (Trend) for 5–17 Month Olds

- Lower COI in vaccine than control group ($p < 0.001$)
- Consistent sieve effects at the CS C-terminus amplicon (full + 4 haplotype regions)
 - Hazards ratio VE: VE(match) ~ 63%, VE(mismatch) ~54%
 - Cumulative VE:
 - Matched VE starts at ~95% and wanes to ~50% by 1 year
 - Mismatched VE starts at ~75% and wanes to ~33% by 1 year
- Significant sieve effects at the CS C-terminus AA positions 299, 301, 317, 354, 356, 359, 361

The Most Sensitive Sieve Study Conducted

1. Large number of clinical endpoint cases
 - RTS,S [5–17 month olds] had 2090 endpoints
 - RV144 for HIV-1 only had 110 endpoints
2. Some study sites had a relatively high frequency of 3D7 matched malaria
3. Sensitive sequencing technology

While the Vaccine Protects Better Against Matched Malaria in 5–17 Month Olds, it Confers Substantial Protection Against Mismatched Malaria

Overall VE = Weighted average of **3D7 matched VE** & **3D7 mismatched VE**

Weights = 8% for 3D7 matched and 92% for 3D7 mismatched

- Therefore, Overall VE is similar to 3D7 mismatched VE

	Overall	Mismatched
Cumulative VE	34.7%	33.4%
Hazard ratio VE	55.8%	54.2%

- The RTS,S vaccine would have higher overall VE in regions with more 3D7 matched malaria

While the Vaccine Protects Better Against Matched Malaria in 5–17 Month Olds, it Confers Substantial Protection Against Mismatched Malaria

Percentage of Vaccinees with Clinical Malaria Endpoint Averted by RTS,S: CS C-Terminus 3D7 Match & Mismatch

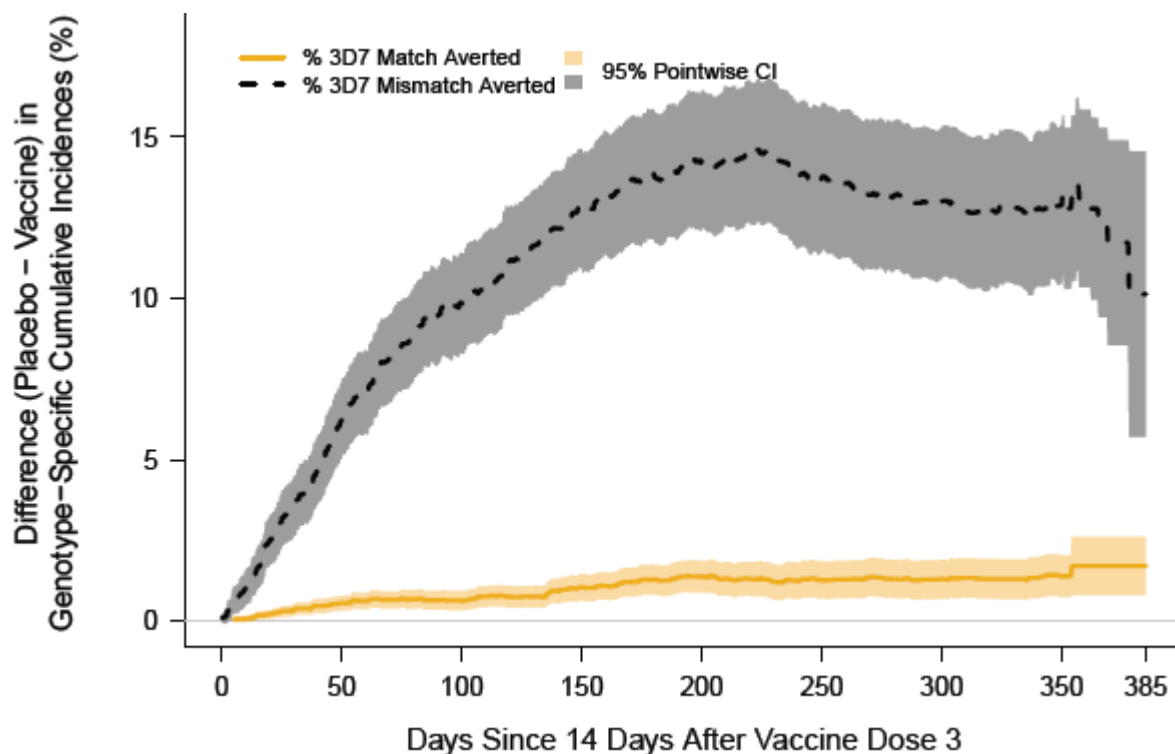

- For every 10,000 5–17 month old RTS,S vaccine recipients, ~ 1200 mismatched and 160 matched malaria cases averted by 12 months

Insights Into Protective Immunity of the RTS,S Vaccine for 5–17 Month Olds

- Suggests multiple components of protective immunity:
 - A non-specific component that confers protection regardless of the parasite sequence, and
 - A sequence-specific component that confers additional protection if there is an identical match between the parasite's CS and the one used in the vaccine

Some Questions (1)

1. How does the RTS,S vaccine partially protect against mismatched genotypes, even with many CS C-terminus mutations?
2. How does vaccination reduce COI in the older but not younger?
3. How come the CS C-terminus genotype and NANP/NVDP repeat sieve effects occur in the older but not younger?
4. Is the concentration of the sieve effect in Western African sites purely a statistical power issue or are there biological/ecological reasons?
5. How come the sieve effects are remarkably consistent across the CS C-terminus full amplicon and 4 haplotype regions?

Some Questions (2)

6. How do the AA sieve signature sites contribute to specific protective epitopes? (T cell epitopes, conformational Ab epitopes, or both?)
7. What studies of RTS,S vaccine immune responses can help discover malaria sequence-specific correlates of protection?
8. What further experiments could be done to further understanding of mechanisms of RTS,S vaccine protection?
9. Would deployment of the RTS,S vaccine select for vaccine-resistant malaria parasites?
10. How to optimize a multivalent version of the RTS,S vaccine?

Summary of Cumulative VE Analysis by Time, Immune Response, and Pathogen Genotype

Symbol	Name	Meaning	Objectives
VE over time			
VE(t)	Overall vaccine efficacy $VE(t) = 1 - P(T \leq t v) / P(T \leq t p)$	Percent reduction (V vs. P) in cumulative risk of the endpoint by time t	Primary objective to assess overall VE by a specified late time-point t Secondary objective: Assess VE over time
VE over time & immune response to vaccination subgroups			
VE(t s)	IR marker subgroup VE: $VE(t S(1)=s) = 1 - P(T \leq t s,v) / P(T \leq t s,p)$	Same as VE(t) in the subgroup with S=s	Secondary objective to assess differential VE(t) by IR marker subgroup (immune CoPs)
VE over time & immune response to vaccination subgroups & pathogen type			
VE(t,j s,x)	IR marker subgroup type j VE: $VE(t,j S(1)=s) = 1 - P(T \leq t, J=j s,v) / P(T \leq t, J=j s,p)$	Same as VE(t s) against the pathogen type j endpoint	Exploratory objective to assess differential type j-immune CoP (type-specific immune CoP effect modification)