

## UNIFORM POLYHEDRALS

BRANKO GRÜNBAUM

*This survey is meant to honor Laszlo Fejes Tóth, who for many years was one of few proponents of visual geometry*

Half a century ago H. S. M. Coxeter, M. S. Longuet-Higgins and J. C. P. Miller published a very influential paper on “Uniform Polyhedra” [7]. These are finite polyhedra with regular polygons as faces, and with vertices in a single orbit under symmetries. *Uniform polyhedrals* are defined by the same conditions, but with *finite* replaced by *locally finite*, and the additional explicit requirement that there are no coinciding elements (vertices, edges or faces); this was self-understood in [7]. Coplanar faces, collinear edges, and partial overlaps are allowed for uniform polyhedrals, as they are for uniform polyhedra. It is somewhat surprising that no systematic study of infinite uniform polyhedrals has been undertaken so far. There are three distinct classes of such polyhedrals – rods, slabs, and sponges. The beginnings of their investigation form the core of this article, and many open problems become evident. Illustrations serve to shorten the explanations, but also to highlight the difficulty of presenting polyhedrals graphically. Applications of such polyhedrals and their relatives in fields such as architecture, biology, engineering, and others are discussed as well, as are the shortcomings of the mathematical reviewing journals in reporting these and related applications of geometry.

### 1. INTRODUCTION

The study of polyhedra more general than the convex ones received a very significant boost in 1954 by the appearance of the long paper “Uniform polyhedra” by H. S. M. Coxeter, M. S. Longuet-Higgins, and J. C. P. Miller [7]. A century of contributions to the topic was surveyed, as well as extended and systematized in a far-reaching manner. The authors’ hope that their enumeration of the polyhedra in question was complete

was vindicated independently by S. P. Sopov [34], J. Skilling [33], and I. Szepesváry [35]. Apart from the actual enumeration of uniform polyhedra, the most significant contribution of [7] was the explicit definition of the concept of “uniform polyhedron”. It is well known that the general idea of “polyhedron” has been left rather murky ever since ancient times, and is still being discussed in many variants. However, the definition of the topic in [7] is simple, crisp and convenient. To quote:

A *polyhedron* is a finite set of polygons such that every side of each belongs to just one other, with the restriction that no subset has the same property. [It is] *uniform* if its faces are regular while its vertices are equivalent under symmetries of the polyhedron.

*Uniform polyhedrals*, the objects discussed in the following pages, could be defined in exactly the same way except that instead of requiring that the set of polygons is finite, we require only that it is *locally finite*, that faces incident with a vertex form a single cycle, and no two vertices, or two edges, or two faces can coincide.

An independent and more generally applicable definition is:

A *polyhedral* is a locally finite and edge-sharing family of polygons, locally and globally strongly connected, with the property that no two vertices, or two edges, or two faces coincide. A *uniform polyhedral* has regular polygons as faces, and its vertices are equivalent under isometric symmetries of the polyhedral.

Since no other kinds are considered here, we shall simplify the language by frequently omitting “uniform” in the following discussion of uniform polyhedrals. It is understood that we are dealing exclusively with polyhedrals in the Euclidean 3-dimensional space.

We still need to clarify what are the regular polygons we admit for our polyhedrals. In contrast to various generalizations that have been considered (for example in [13], [15], [16], and other papers) and that could be used in the study of uniform polyhedrals, here we restrict attention to the classically accepted polygons denoted by  $\{n/d\}$ , for relatively prime  $n$  and  $d$ , with  $1 \leq d \leq n/2$ , where  $n$  is the number of edges (and vertices) and  $d$  the “density” (see, for example, [7]).

Since the finite uniform polyhedrals have been adequately described in the literature – there are three infinite families and 75 individual ones – most of our attention will go to the infinite polyhedrals. It is easy to see that it is

convenient to distinguish three classes of infinite uniform polyhedrals: *rods* are infinite in one direction, *slabs* are infinite in two independent directions, and *sponges* are infinitely extended in three independent directions. Simple examples are shown in Fig. 1. The following sections will discuss each of these classes in considerable detail. But it seems worth mentioning that it appears strange that the finite polyhedrals, and the three classes of infinite polyhedrals, have not been considered together, even though they share many characteristics. One of the main aims of the following pages is the enumeration of the different kinds of polyhedrals – to the extent that this is known. Besides the *acoptic* (selfintersection-free) infinite polyhedrals, we shall pay particular attention to the non-acoptic ones; these seem not to have been considered in the literature at all.

The primary characteristics of all uniform polyhedrals is the local specification of the neighborhood of each (hence every) vertex by its *vertex star* – the circuit of polygons (faces) that are incident with the vertex. The vertex star can be recorded by the *vertex symbol*, such as (4.6.8); exponents are sometimes used to shorten the symbol. Additional examples are given in Fig. 1.

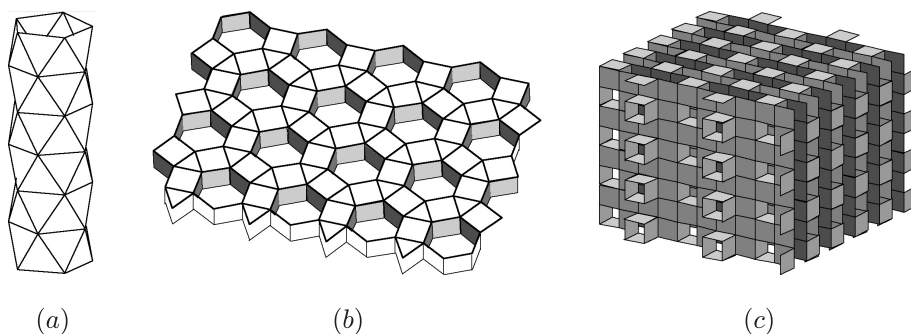

Fig. 1. (a) A rod with vertex symbol  $(3^6)$ . (b) A slab with vertex symbol  $(3.4^4)$ .  
(c) A sponge with vertex symbol  $(4^5)$

Finite polyhedrals are uniquely determined by their vertex stars. Hence the vertex symbol, such as (3.4.5.4) or (6.6.5/2), is generally accepted as the identification symbol of the polyhedral.

For infinite polyhedrals this is not the case in general, and additional information needs to be specified for identification. This information requires two distinct components. First, the *shape* of the vertex star should be specified by listing the dihedral angles between the successive faces of the vertex star. In some cases this is determined by the other data – for exam-

ple, for the unique polyhedral with vertex symbol (5.5.5.5.5), see Section 5. The other identifying component is the *adjacency symbol* of the polyhedral. This establishes the relation between adjacent vertex stars, that is, those that share an edge. By the definition of polyhedrals, the adjacency symbol is the same for all pairs of adjacent vertices, hence it is associated with the polyhedral itself. Together with the identification of the class (rod, slab, or sponge), these data determine the polyhedral uniquely. However, this way of describing individual polyhedrals is rather inconvenient and laborious, and except in the case of sponges, simpler possibilities exist. Hence we shall delay discussing the adjacency symbols till Section 6.

The three classes of infinite uniform polyhedrals are analogous to the infinite isohedral polyhedra the study of which was proposed in [18] thirty years ago, along with that of the infinite uniform polyhedrals in the sense of the present paper. However, it appears that this publication has not had any influence on later developments.

## 2. FINITE UNIFORM POLYHEDRALS

The best introduction to the finite polyhedrals is still the long paper [7] by Coxeter *et al.*, supplemented by the images of physical models in Wenninger's book [42]. The Internet has many excellent presentations, such as those of V. Bulatov [2], G. W. Hart [20], [21], Maeder [27], E. W. Weisstein [42], Wikipedia [43], [44], and many other pages.

We shall not enlarge upon the 75 particular finite uniform polyhedrals, but need to describe the three infinite families – the prisms and the antiprisms – since we shall have to refer to them in connection with the uniform rods.

Each of the prisms and an isms has as its two bases congruent regular polygons  $\{n/d\}$ , where  $1 \leq d < n/2$  and  $d$  is relatively prime to  $n$ . The prisms have vertex symbols  $(4.4.n/d)$ , while the antiprisms have vertex symbols  $(3.3.3.n/d)$ . However, there are two varieties of antiprisms. The *ordinary* antiprism  $(3.3.3.n/d)$  exists for all the  $n$  and  $d$  satisfying these conditions. The *crossed* antiprism  $(3.3.3.n/d)$  exists only if, in addition,  $n/3 < d < n/2$ . The difference between the two varieties is that the triangles of the ordinary antiprisms do not cross the axis of rotational symmetry of the antiprisms, while the triangles of the crossed antiprisms do cross it. In [7] and many other publications the crossed antiprism with  $\{n/d\}$  bases

is denoted  $(3.3.3.n/(n-d))$ . We shall adhere to this notation. We illustrate prisms and antiprisms in Fig. 2.

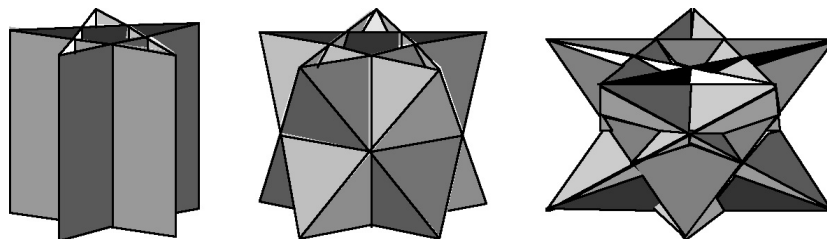

Fig. 2. The pentagram-based prism (4.4.5/2) and antiprisms (3.3.3.5/2) and (3.3.3.5/3)

### 3. UNIFORM RODS

There are three classes of uniform rods: stacked, ribboned, and helical. (However, see Note in Section 7.) Due to the assumed isogonality of each rod, all its vertices must be on a cylindrical surface. Hence uniform rods can have only squares or equilateral triangles as faces. The squares must have edges parallel and perpendicular to the axis of the prism. The first publication that illustrates all three kinds of (acoptic) rods is [41].

Each *stacked rod* is formed by an infinite stack of modules (modular units); each module consists of the faces that form the mantle of a prism or antiprism. The stacked rod is *unary* if all its modules are of the same kind (hence are congruent, see Fig. 3), and it is *binary* if its modules are of different kinds. In the latter case, for each pair of modules there are always two possibilities: Adjacent modules are either on opposite sides of the plane of the common bases, or on the same side – see Fig. 4. The same-side variant is possible without violating the non-coincidence restriction since the altitudes of different modules (with the same basis) are unequal.

*Ribboned rods* have vertical ribbons of either squares or triangles. *Unary* ribboned rods with squares are the same as stacked rods  $(4.4.4.4)_n$ . Hence the only unary ribboned rods that need to be considered are the ones with triangles. Some examples of acoptic (selfintersection-free) rods  $R(3.3.3.3.3.3)_n$  of this kind are shown in Fig. 5(a). It should be noted that adjacent ribbons are translates of each other by a half-length of a side. Hence the number of ribbons must be even, regardless of whether the rod is acoptic or not. If the intended cross-section of the rod is  $\{n/d\}$  with

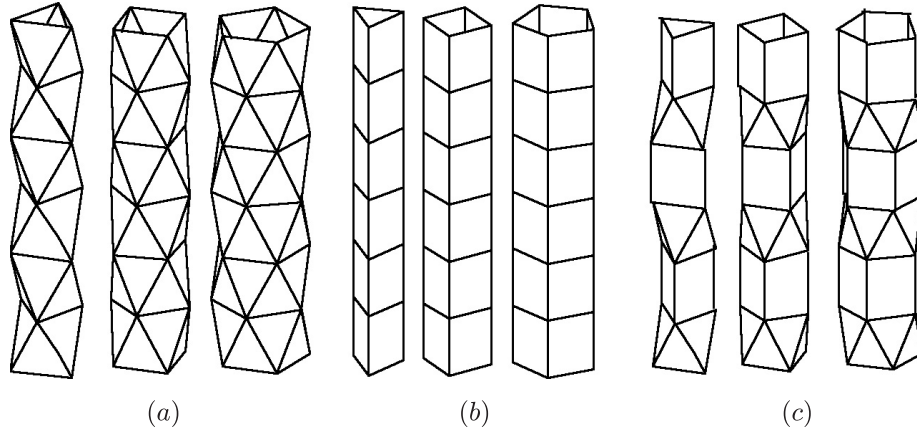

Fig. 3. Uniform acoptic stacked rods with  $\{n\}$  bases,  $n = 3, 4, 5$ . (a) Unary triangle-faced rods  $(3.3.3.3.3.3)_n$ . (b) Unary square-faced rods  $(4.4.4.4)_n$ . (c) Binary rods  $(3.3.3.4.4)_n$

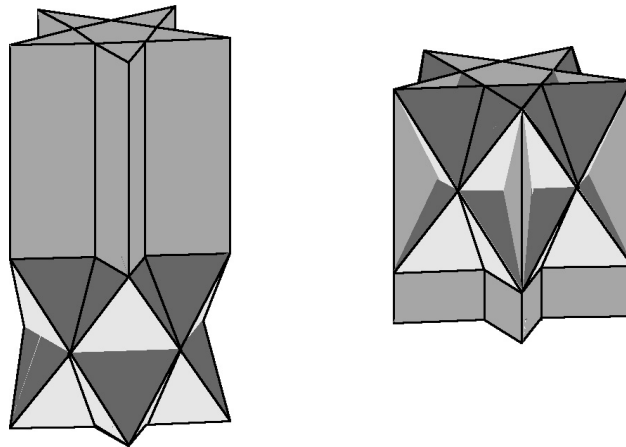

Fig. 4. Two possible pairs of modules with  $\{5/2\}$  bases, leading to binary stacked rods that can be denoted  $(3.3.3.4.4)_{5/2}$  and  $(3.3.3. - 4. - 4)_{5/2}$ , respectively. Notice that in the latter rod there are several simultaneous overlaps of squares. There are four other binary stacked rods with pentagrammatic bases:  $(3.3.3.4.4)_{5/3}$  and  $(3.3.3. - 4. - 4)_{5/3}$ ,  $(3.3.3.3.3.)_{5/2,5/3}$  and  $(3.3.3. - 3. - 3. - 3)_{5/2,5/3}$

$n$  odd, the number of ribbons must be doubled. Then the ribbons coincide in pairs, but with a displacement of half an edge-length in the direction of the axis of the rod. Thus the evenness requirement is satisfied, as is the non-coincidence of faces. Hence the rod  $R(3.3.3.3.3)_{n/d}$  with odd  $n$  has  $2n$  ribbons. I have found no satisfactory way of presenting meaningful illustrations of such ribboned rods; attempts are made in the simplest cases in

Fig. 5(b). Equally hard to show are selfintersecting (multiply wound) ribboned rods  $R(3.3.3.3.3.3)_{n/d}$  in which the cross-section is a regular polygon  $\{n/d\}$ , with  $d > 1$  and with  $d$  and  $n$  relatively prime. Fig. 6 illustrates the unary ribboned rod  $R(3.3.3.3.3.3)_{8/3}$ .

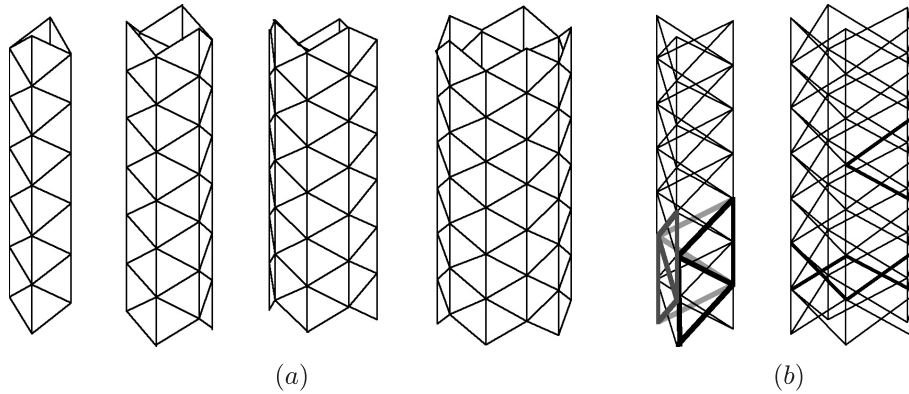

Fig. 5. (a) Acoptic unary ribboned rods  $R(3.3.3.3.3.3)_n$ , for  $n = 4, 6, 8, 10$ . (b) Unary ribboned rods  $R(3.3.3.3.3.3)_3$  and  $R(3.3.3.3.3.3)_5$

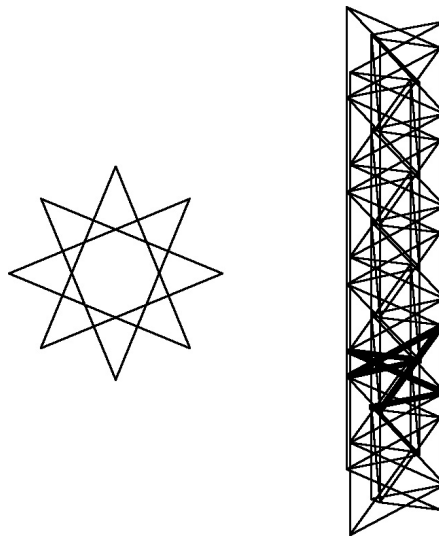

Fig. 6. The ribboned rod  $R(3.3.3.3.3.3)_{8/3}$  shown alongside its cross-section

*Binary* ribboned rods  $R(3.3.3.4.4)_{n/d}$  have  $n$  ribbons with squares and  $n$  ribbons with triangles, if  $n$  is even, and twice these numbers if  $n$  is odd. Examples of acoptic binary ribboned rods are shown in Fig. 7. For

selfintersecting binary ribboned rods it is most appropriate to show their cross-section, see Fig. 8; each of these is an *isogonal* polygon, with sides alternating in length in ratio  $\sqrt{3}/2$ .

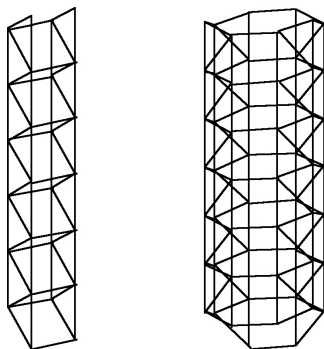

Fig. 7. Acoptic binary ribbons  $R(3.3.3.4.4)_2$  and  $R(3.3.3.4.4)_4$

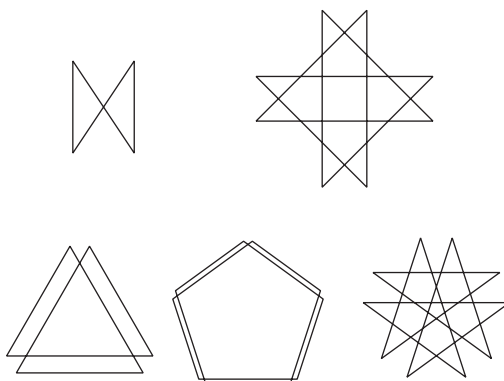

Fig. 8. Isogonal polygons with ratio of sides  $\sqrt{3}/2 = 0.866\dots$ . These are cross-sections of binary ribbons  $R(3.3.3.4.4)_n$  with  $n = 4/2, 8/3, 6/2, 10/2, 10/3$ , respectively

*Helical rods* are possible only with triangles. The rods shown in Fig. 9 are the simplest acoptic ones. They are obtainable by selecting a suitable strip from the regular tiling by triangles, and wrapping it *once* (for acoptic rods) or *several* times around a cylinder. The process is explained in Fig. 10, but see the comments in Section 7. As far as I am aware, non-acoptic helical rods have not been mentioned in the literature; my technological limitations have prevented me from showing any here.

It is worth mentioning that an extension of the notation explained in Fig. 10 could also be used to designate ribboned rods  $R(3.3.3.3.3)_n$  as  $(n, n, 2n)$ , and the stacked rods  $(3.3.3.3.3)_n$  as  $(0, n, n)$ .



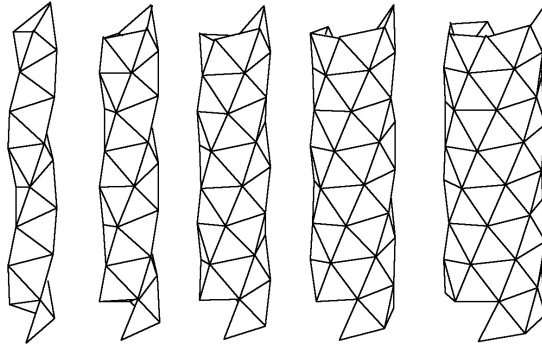

Fig. 9. Acoptic helical rods. In the notation explained in Fig. 10, they can be described by  $(1, m, m + 1)$ , for  $m = 2, 3, 4, 5, 6$

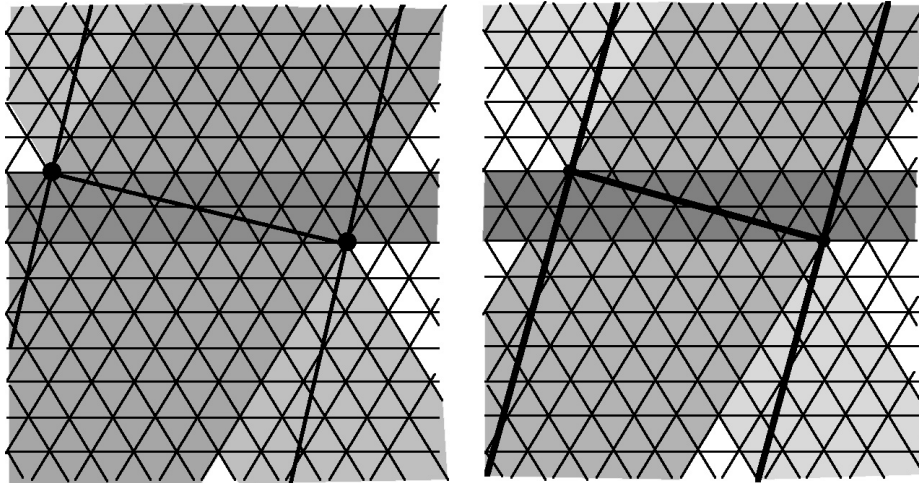

Fig. 10. The construction of the helical rods  $(1, 4, 5)$  and  $(2, 5, 7)$ . In each case the strip between the parallel heavily drawn lines should be used to generate the rod by making the two heavy dots coincide. The perpendicular to these lines (which becomes an equatorial section of the rod) is intersected by 1, 4, and  $5 = 1 + 4$ , and by 2, 5, and  $7 = 2 + 5$  helical strips of triangles, respectively; this explains the notation  $(1, 4, 5)$  and  $(2, 5, 7)$  for these helical rods. The general acoptic helical rod has symbol of the form  $(m, n, m + n)$ , with  $1 \leq m < n$ ; the notation for non-acoptic helical rods is  $(m, n, m + n)/k$  if the triangles of the rod form a rod of type  $(m, n, m + n)$ , that winds  $k \geq 1$  times about the axis

## 4. UNIFORM SLABS

To describe uniform slabs it is convenient to distinguish four kinds: Tilings, corrugates, crinkles, and tunneled slabs.

*Uniform tilings* are slabs that are isogonal collections of regular polygons filling up a plane without overlaps. There are eleven acoptic ones – the traditional three *regular* tilings with vertex symbols (4.4.4.4), (6.6.6), (3.3.3.3.3.3), and eight *Archimedean* tilings with vertex symbols (3.3.3.4.4), (3.3.4.3.4), (4.8.8), (3.3.3.3.6), (4.6.12), (3.4.6.4), (3.12.12), (3.6.3.6) – as well as fourteen non-acoptic ones. Some of the latter were first investigated in the 19th century by A. Badoureau [3], and the full enumeration was carried out by J. C. P. Miller [28] in 1933. The first actual publication of the complete list (without illustrations) was by Coxeter *et al.* [7, Table 8]; the full enumeration with illustrations is accessible in [17]. The fourteen non-acoptic ones can be characterized by their vertex stars shown in [17], and the corresponding (modified) vertex symbols; the modification consists in a change of sign if two adjacent polygons are not oriented in the same way. The vertex symbols (see [17]) are:

(3.3.3. – 4. – 4) illustrated in Fig. 11; (3.3. – 4.3. – 4); (4. – 8.8/3); (8.8/3. – 8. – 8/3); (–4.8/3.8/3); (6. – 12.12/5); (4. – 6.12/5); (–3.12.6.12); (4.12. – 4. – 12); (3. – 4.6. – 4); (3.12/5. – 6.12/5); (4.12/5. – 4. – 12/5); (12.12/5. – 12. – 12/5); (–3.12/5.12/5).

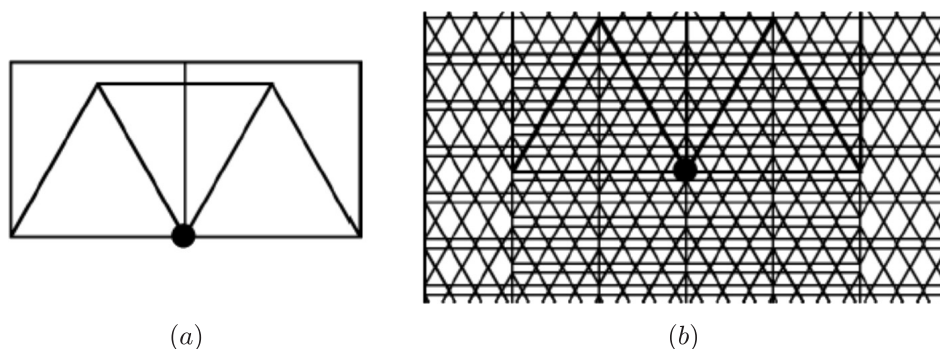

Fig. 11. The non-acoptic uniform tiling (3.3.3. – 4. – 4). (a) The vertex star.  
(b) A patch of the tiling, illustrating the multiple overlaps of the tiles

*Corrugations* or *corrugated tilings* are slabs obtained from appropriate uniform tilings (the ones with only triangles or squares as tiles) by bending them out of the plane along complete lines formed by edges of the tiling.

Hence only tilings (3.3.3.3.3), (4.4.4.4), (3.3.3.4.4), and (3.3.3. - 4. - 4) can be used. The amount of bending can be specified by an angle; in Fig. 12 we indicate the lines that are used for the bends by marking the *ridges* and *valleys*, and the cross-sections perpendicular to the lines of bends for the (4.4.4.4) tiling, which show the angles  $\alpha$  of bend for each slab. The corrugated slabs arising from (3.3.3.3.3) are analogous. The corrugated slabs arising from (3.3.3.4.4) are the same as those arising from (3.3.3. - 4. - 4); there are three parametrized families, indicated in Fig. 13. Thus there are precisely seven parametrized families; in the acoptic case these were first specified in [41]. Hughes Jones [23] provides examples of the corrugated slabs (3.3.3.3.3) for a specific value of  $\alpha$ .

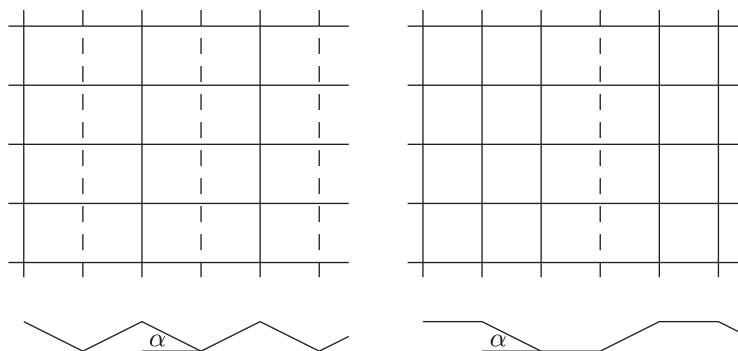

Fig. 12. The two families of corrugated slabs derived from the (4.4.4.4) tiling. (a) Here  $0 < \alpha < \pi/2$ . (b) Here  $0 < \alpha < \pi$ ; note that for  $\alpha \geq 2\pi/3$  the slab is selfintersecting

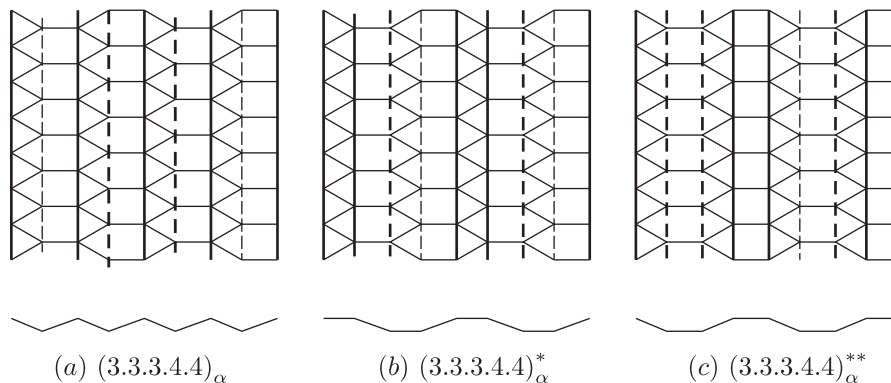



Fig. 13. The three corrugations that arise from (3.3.3.4.4) (and also from (3.3.3. - 4. - 4)). (a) The angle of bend satisfies  $0 < \alpha < \pi/2$ . (b) Here  $0 < \alpha < \pi$ ; note that for  $\alpha \geq 115.66^\circ$  the slab is selfintersecting. (c) Here  $0 < \alpha < \pi$  as well; note that for  $\alpha \geq 125.26^\circ$  the slab is selfintersecting

*Crinkles* or *crinkled tilings* are obtained in a way similar to corrugations, by appropriately bending certain tilings. The tilings which can be used are (3.3.3.3.3), (3.3.3.4.4), and (3.3.4.3.4). The four families of crinkles are parametrized by a real parameter. Details are shown in Fig. 14. The term “crinkle” seems to appear first in [23], where it is used to denote the crinkle (3.3.3.3.3)<sub>α</sub><sup>#</sup> for a specific value of  $\alpha$ . The crinkle in Fig. 14(a) was devised by the present writer in the early 1990’s; the other three crinkles were invented by William Webber shortly thereafter. They have not been published so far, and I am grateful to Professor Webber for allowing their inclusion here.

The last kind of uniform slabs are the *tunneled slabs*. A uniform tunneled slab consists of two copies of a tiling (usually a uniform tiling), placed in parallel planes, and from which an appropriate family of tiles is removed. The resulting holes in the two tilings are connected by suitable mantles of Archimedean prisms or antiprisms. (In fact, among the antiprisms only the mantle of the 3-antiprism – that is, the octahedron – is usable.) There are 18 acoptic tunneled slabs. All these appear in [41] – I am not aware of any other publication or internet page that presents them all. The non-acoptic ones are presented here for the first time.

There are two simple ways of symbolically presenting tunneled tilings. The generating symbol starts from the symbol of the tiling, by indicating in its vertex symbol the tile that is being omitted; this can be done, for example, by underlining the symbol of the omitted tile. As an illustration, the tunneled slab in Fig. 1(b) has the symbol (3.4.6.4). The other way is by simply listing the vertex symbol of the tunneled slab. The former is more intuitive but there are two drawbacks. On the one hand, (3.3.3.3.3) can denote two distinct tunneled slabs, with vertex symbols (4.4.3.3.3.3) and (3.3.3.3.3.3.3); similarly, (3.6.3.6) corresponds to both (4.4.6.3.6) and (3.3.3.6.3.6). On the other hand, the

Two  tunneled slabs that correspond to (4.4.4.4), that are shown in Fig. 15, both have vertex symbol (4.4.4.4.4), hence cannot be distinguished by either unless one adds asterisks or some other ad hoc notation. Adjacency symbols (which we shall discuss in the next section) distinguish between these two – the more symmetric slab has adjacency symbol ( $ab^+c^+c^-b^-$ ;  $ab^-c^-c^+b^+$ ), the other slab has symbol ( $a^+b^+c^+d^+e^+$ ;  $a^-b^+c^-d^-e^-$ ).

The complete list of 18 acoptic tunneled slabs is:

$$(3.3.4.3.4) = (3.3.4.4.3.4), \quad (\underline{4}.8.8) = (4.4.8.8), \quad (4.\underline{8}.8) = (4.4.4.8), \\ (\underline{4}.4.4.4) = (4.4.4.4.4)^*, \quad (\underline{4}.4.4.4) = (4.4.4.4.4)^{**},$$

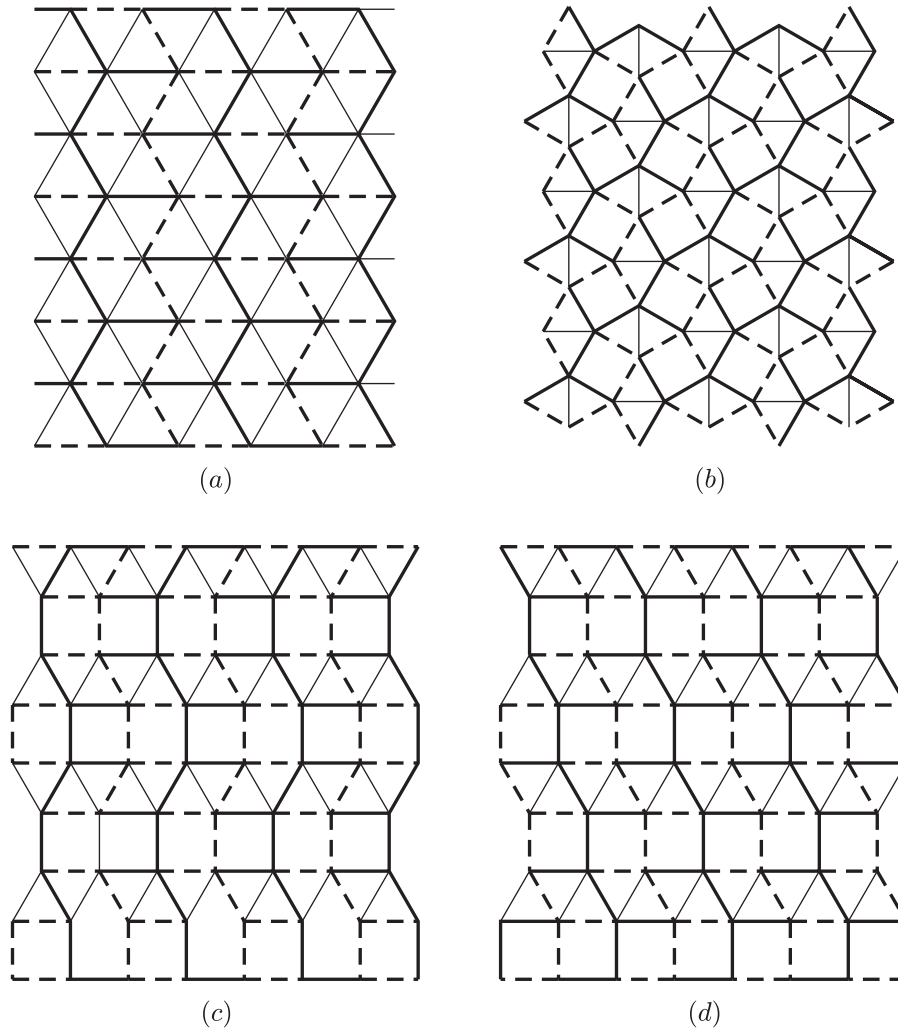
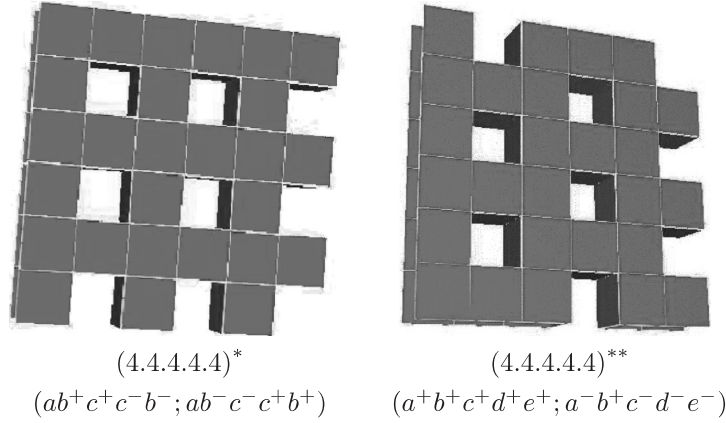

Fig. 14. The four parametrized families of crinkles. (a)  $(3.3.3.3.3.3)_\alpha^\#$ ; (b)  $(3.3.4.3.4)_\alpha^\#$ ; (c)  $(3.3.3.4.4)_\alpha^\#$ ; (d)  $(3.3.3.4.4)_\alpha^{\#\#}$ , where  $\alpha$  denotes the angle of the bend. For  $\alpha \rightarrow 0$  each tends to the corresponding tiling. If  $\alpha \rightarrow \pi$ , the crinkle  $(3.3.3.3.3.3)_\alpha^\#$  has a discontinuity:  $(3.3.3.3.3.3)_\alpha^\#$  is a (2-dimensional) crinkle, while  $(3.3.3.3.3.3)_\pi^\#$  is just a strip of triangles. If  $\alpha \rightarrow \pi$ ,  $(3.3.4.3.4)_\alpha^\# \rightarrow (3.3.3. - 4. - 4)$ , which is the tiling illustrated in Fig. 11. The crinkles in (c) and (d) have in fact three different angles of bend;  $\alpha$  denotes the bend along edges between triangles. For  $\alpha \rightarrow \pi$ , each of these crinkles tends to a non-acoptic structure that is not a uniform polyhedral

$$\begin{aligned}
 (3.3.3.3.\underline{6}) &= (3.3.3.3.4.4), & (3.3.3.\underline{3}.6) &= (3.3.4.4.3.6), \\
 (\underline{4}.6.12) &= (4.4.6.12), & (4.\underline{6}.12) &= (4.4.4.12), & (4.6.\underline{12}) &= (4.4.4.6),
 \end{aligned}$$



*Fig. 15.* Two distinct tunneled slabs that cannot be distinguished by their vertex symbols without the asterisks. These slabs, as well as the illustrations in Section 5, were created by Steven Gillispie

$$\begin{aligned}
 (3.4.6.4) &= (4.4.4.4.6), & (3.4.6.4) &= (3.4.4.4.4), & (3.12.12) &= (4.4.12.12), \\
 (6.6.6) &= (4.4.6.6), & (3.3.3.3.3.3) &= (3.3.3.3.3.4.4), \\
 (3.3.3.3.3.3) &= (3.3.3.3.3.3.3.3), & (3.6.3.6) &= (3.6.4.4.6), \\
 (3.6.3.6) &= (3.3.3.6.3.6).
 \end{aligned}$$

Known selfintersecting tunneled slabs are:

$$\begin{aligned}
 (3.3. - 4.3. \underline{-4}) &= (3.3. - 4.3. - 4. - 4), & (\underline{4.} - 8.8/3) &= (4.4. - 8.8/3), \\
 (4. \underline{-8.8/3}) &= (4. - 4. - 4.8/3), & (4. - 8.8/3) &= (4.4.4. - 8), \\
 (8.8/3. - 8. - 8/3) &= (4.4.8/3. - 8. - 8/3), \\
 (8.8/3. - 8. - 8/3) &= (8.4.4. - 8. - 8/3), \\
 (\underline{-4.8/3.8/3}) &= (-4. - 4.8/3.8/3), & (-4.8/3. \underline{8/3}) &= (-4.4.4.8/3), \\
 (6. - 12.12/5) &= (4.4. - 12.12/5), & (6. \underline{-12.12/5}) &= (6. - 4. - 4.12/5), \\
 (6. - 12.12/5) &= (6. - 12.4.4), & (\underline{4.} - 6.12/5) &= (4.4. - 6.12/5), \\
 (4. \underline{-6.12/5}) &= (4. - 4. - 4.12/5), & (4. - 6.12/5) &= (4.4.4. - 6), \\
 (\underline{-3.12.6.12}) &= (-4. - 4.12.6.12), & (-3.12.6.12) &= (-3.12.4.4.12), \\
 (3. - 4.6. - 4) &= (4.4. - 4.6. - 4), & (3. - 4.6. - 4) &= (3. - 4.4.4. - 4), \\
 (3.12/5. - 6.12/5) &= (4.4.12/5. - 6.12/5),
 \end{aligned}$$

$$(3.12/5.\underline{-6}.12/5) = (3.12/5. - 4. - 4.12/5),$$

$$(\underline{-3}.12/5.12/5) = (-4. - 4.12/5.12/5).$$

It is an unconfirmed conjecture that this list of 21 selfintersecting tunneled slabs is complete.

One additional observation about the tunneled slabs is worth mentioning. Several of them are not rigid – they admit of continuous deformations in the 3-dimensional space. However, in contrast to the corrugations and crinkles, that stay uniform through the deformation, the deformed tunneled slabs are not uniform; they are not even *monogonal* (that is, the vertex stars of the deformed slabs are not all congruent, regardless of symmetries).

## 5. UNIFORM SPONGES

Uniform sponges come in a wide variety of types; they are only poorly known, and no overall classification has been proposed at this time. Two kinds that we are able to characterize in a reasonable way are the *isotropic* sponges and the *layered* sponges; see Fig. 16. An example of a uniform sponge that is of neither of these kinds is shown in Fig. 17. The present account of uniform sponges is based mainly on [10], and on unpublished joint research with Steven Gillispie.

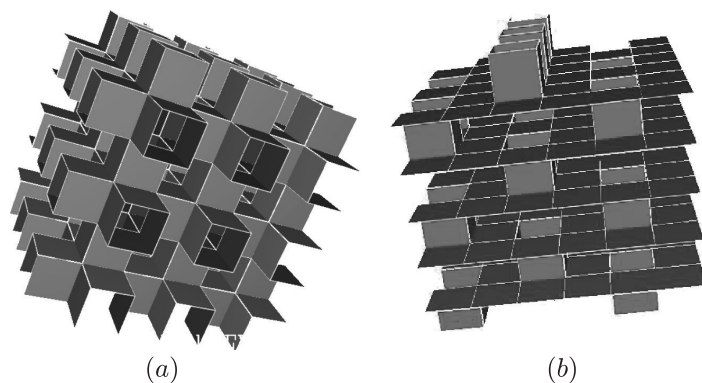

Fig. 16. (a) An isotropic sponge (4.4.4.4.4) with incidence symbol  $(a \hat{a} a \hat{a} a \hat{a} \hat{a}; a)$ . This is one of the three regular Coxeter–Petrie sponges; all are isotropic. (b) A layered sponge (4.4.4.4.4) with incidence symbol  $(a^+ b^+ c^+ d^+ e^+; a^- b^- c^- d^+ e^-)$

An *isotropic sponge* is periodic in three independent directions, that are equivalent under symmetries of the sponge.

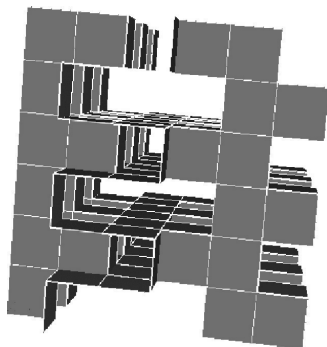

Fig. 17. A uniform sponge  $(4.4.4.4) = (a^+b^+c^+d^+e^+; a^-b^+c^-d^+e^-)$  from [10], where it is denoted  $N1$ . Like several other sponges from [10], this is neither isotropic nor layered. It was first described in [14]

A *layered sponge* consists of a series of copies of a family of polygons in parallel planes, connected by “tunnels” or “barriers”. The family of polygons is usually a tiling of the plane from which some tiles have been removed, so that the “tunnels” or “barriers” can be attached. The “tunnels” and “barriers” are formed either by squares (as in the tunneled example below), or else by triangles, just as in the case of the tunneled slabs. For each plane, some of these tunnels go above and some below the plane itself. Each “barrier” is a strip, straight or zigzag, and either perpendicular to the planes or inclined at a suitable angle; again, some go up and some go down from the plane.

Here is a brief survey of the history of uniform sponges.

The first mention of such objects is in Coxeter’s paper [5], where he describes specific sponges  $(4.4.4.4.4.4)$ ,  $(6.6.6.6)$ , and  $(6.6.6.6.6.6)$ . These are *regular* in the sense that the symmetries act transitively on the flags of each, where a *flag* is a triple consisting of a vertex, an edge, and a face, all mutually incident; in that context the appropriate Schläfli symbols are  $\{4, 6\}$ ,  $\{6, 4\}$ , and  $\{6, 6\}$ . Moreover, Coxeter proved that there are no other regular sponges.

Several individual sponges were described in the 1950’s and later; however, in most cases there was no attempt at finding any general results or points of view. The same can be said for the various appearances of sponges on the Internet. More detailed references may be found in [10]. Of greater interest is the work of Gott [12], who described several sponges, including the three regular ones. The most interesting of Gott’s sponges is a  $(5.5.5.5.5)$



uniform sponge shown in Fig. 18. He also illustrates the acoptic tunneled slab we denoted by  $(3.3.3.3.3.3) = (3.3.3.3.3.3.3.3)$ .



Fig. 18. The (5.5.5.5.5) uniform sponge discovered by Gott [12]

The largest collection of uniform sponges is [41], with photos of over eighty cardboard models of different sponges; the precise number depends on the definition of “different sponges”, which will occupy us soon. This work introduced concepts close to isotropic and layered sponges, albeit with different terminology.

The next noteworthy collection of uniform sponges is that of Hughes Jones [23], which gives details on 26 special acoptic sponges  $(3^k)$  with triangular faces and with  $7 \leq k \leq 12$ . The faces of Hughes Jones’ sponges are required to be among the faces of the tiling of 3-space by tetrahedra and octahedra. Of the slabs, he lists the two corrugations and one crinkle; he mentions that he knows 11 other uniform sponges with triangular faces, that are not derived from the tiling by tetrahedra and octahedra.

Goodman-Strauss and Sullivan [11] characterized the (4.4.4.4.4.4) sponges that have faces among the squares of the cubic lattice. They proved that there are precisely six distinct acoptic sponges of this kind. The approach taken in [11] excludes selfintersecting sponges.

The most recent addition to this list is the paper [10]. It presents an enumeration of the (4.4.4.4.4) acoptic uniform sponges with faces among the squares of the cubic lattice. There is a total of 15 different types; it should be noted that two of the types are slabs (see Fig. 15 above), which in the present paper are not considered to be sponges. However, the main importance of [10] is the presentation of a computational model that can be used in the study of arbitrary uniform sponges. The next several pages will be devoted to an explanation of this program.

As in many other contexts – for example, the enumeration of isohedral tilings or other symmetrical objects – the first step is the replacement of the geometric sponges by combinatorial objects which yield “candidates” for realization by geometric sponges; these can then be drawn and inspected, or investigated by other means. Several illustrations of this idea are detailed in [18].

In the case of sponges, we start by considering the vertex star of a family of sponges we wish to investigate, and label its edges incident with the central vertex. The procedure is illustrated by the example of the (4.4.4.4) sponges with faces in the cubic lattice; this is taken from [10], where additional details (omitted here for brevity) can be found. As indicated in Fig. 19, this particular vertex star needs two different labelings; each is shown with a canonical “vertex star label”. Either no symmetry among the edges is invoked, or else the symmetry is encoded in the labeling. If an edge  $x^+$  of a vertex star is mapped onto another by a reflection, the reflected edge needs to be marked  $x^-$ . An edge  $x^+$  mapped onto itself by a reflection is relabeled as  $x$ . This leads to the vertex star labels shown in Fig. 19. (In cases where a vertex symbol is associated with several vertex stars, each

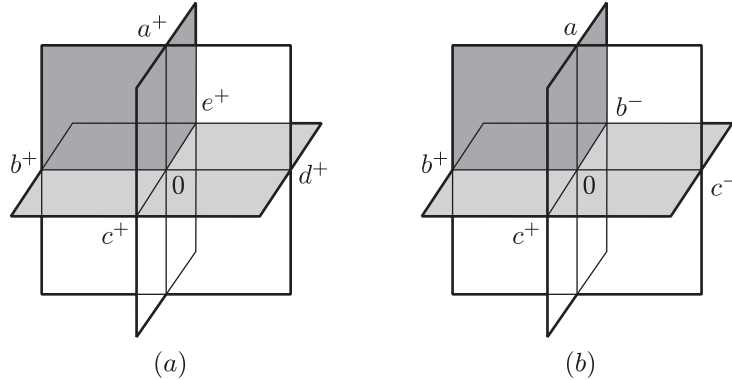

Fig. 19. The two labeled vertex stars ( $4^5$ ) possible in the cubic lattice. (a) Asymmetric vertex star label  $a^+b^+c^+d^+e^+$ . (b) Symmetric vertex star label  $a^+b^+c^+c^-b^-$ , using the mirror that contains the  $Oa$  edge and bisects the angle  $c^+Oc^-$ . Other symmetries that a vertex star may possess lead to other vertex star labels

vertex star has to be treated separately, for each of its (inequivalent) vertex star labels. For example, the symbol (4.4.4.4.4) in the cubic lattice is associated with the two vertex stars in Fig. 20, each of which admits several vertex star labels.) Among other possible maps of an edge onto itself we mention the *flip*, which exchanges the *sides* of the vertex star. This is indi-

cated, for an edge labeled  $x$ , by  $x^\wedge$ , and similar notation is introduced for other possibilities. For example, the right part of Fig. 20 can have vertex star label  $aa^\wedge aa^\wedge aa^\wedge$ . Since we are not trying to reproduce [10] here, the reader is again urged to consult that paper for details and specifics.

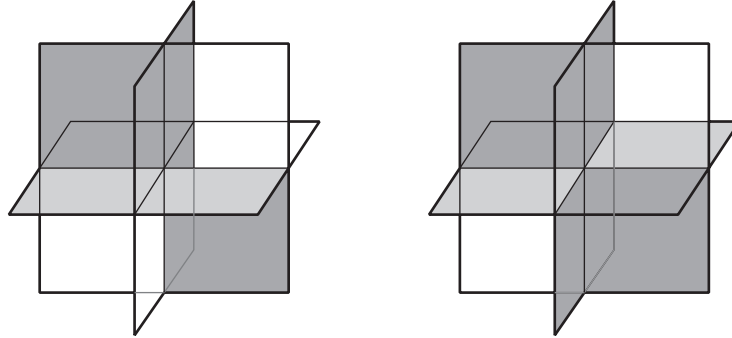

Fig. 20. The two vertex stars associated in the cubic lattice with the vertex symbol  $(4^6)$ . Each admits several vertex star labels

The vertex star label constitutes the first part of the *incidence symbol*. The second part is the *adjacency symbol*. For each edge at a chosen vertex, the adjacency symbol specifies which symmetry carries its vertex star to the vertex star of the vertex at the other end of the edge. Since the labels given to the edges of one vertex star are, by the assumed isogonality, automatically transferred to all vertices, we only need to specify for each symbol of the vertex star label of the starting vertex which is the symbol of that edge in the vertex star label of the other end of the same edge. The reader is invited to verify the adjacency symbols we attached to the slabs and sponges in Figures 15, 16, and 17.

Once an incidence symbol has been chosen, the program in [10] attempts to build a valid polyhedral by combining multiple copies of the vertex star according to the incidence symbol. The various steps described in [10] apply in great generality.

## 6. THE “TYPE” OF SPONGES

Among uniform polyhedrals, the sponges are the least explored and understood. One critical question, which arises in enumerations of objects of any kind, is how to decide when two of the objects are “the same”, or “of the

same type”, for the purposes of the enumeration. As long as we assume ahead of time that the sponges have faces among a preassigned set (such as the cubic lattice in [11] and [10], or the faces of the tiling of 3-space by tetrahedra and octahedra in [23]), there is no difficulty: Sponges that look different are assigned to different types. However, if one does not insist that the vertex stars be taken from a finite, discrete set of possibilities, this situation changes. For example, the two sponges in Fig. 21 certainly appear different, but since they have the same adjacency symbol it is not obvious by what criteria they should be used to decide whether they are of the same type or different types. Clearly, no enumeration of possible types of a certain kind of sponges – such as the  $(4^5)$  sponges – can be attempted before this question is settled in a meaningful and practicable way.

This concern is not something abstract; it has occurred in actual attempts at enumeration, such as [41]. Besides two  $(4^5)$  slabs, there are nine  $(4^5)$  sponges shown in [41]. Two of these – which the authors denote by  $4^5(4)$  and  $4^5(6)$  – are analogous to the two sponges in our Fig. 21, but with the tunnels in adjacent layers shifted by one step. Thus, although considered to be two different sponges, they are in fact two representatives of a continuum of sponges with the same adjacency symbol  $(a^+b^+c^+d^+e^+; a^-b^-c^-d^-e^-)$  and with the same symmetry group; it would appear reasonable to consider all these to be of the same “type”. It would seem that a satisfactory definition of two sponges being of the same “type” would involve the equality of their adjacency symbols, and the continuous deformability of their vertex stars into each other, subject to certain reasonable and well-defined restrictions. However, the exact nature of these restrictions has not been determined so far. Moreover, there is still the question whether the intuitive feeling that the sponge in Fig. 21(a) is somehow different from the other sponges of the same “type” can be (or should be) rationalized and codified in some way.

As a consequence of these difficulties, it is at this time impossible to state for any vertex symbol  $(a.b. \dots .g)$  how many different “types” of sponges it admits; the only known exception is the sponge  $(5^5)$  of Gott [12] that has the single realization as an unlabeled sponge, shown in Fig. 18. Even the more basic question whether there are *any* sponges with a given vertex *symbol*  $(a.b. \dots .g)$  does not have any general solution at this time. The algorithm in [10] at best only produces all candidate sponges for a given vertex *star*.

Only acoptic uniform sponges were considered in [14]. In this context, several conjectures made there are still open, and it is appropriate to mention them now.

- No vertex star of an acoptic sponge has more than 12 faces.
- If the vertex star of an acoptic sponge is incident with more than eight faces, then all faces are triangles.
- No acoptic sponge has only faces with seven or more sides.

There is no information on which to base guesses concerning the analogues of these conjectures if the sponges are not assumed to be acoptic.

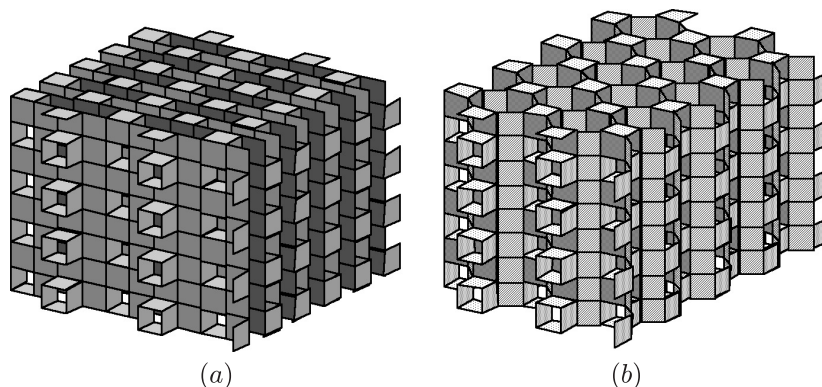

*Fig. 21.* The sponge in (a) is another view of the sponge in Fig. 16(b). It can be “stretched” (or “flexed”) in a continuous way to yield the one in (b). Both have the same adjacency symbol  $(a^+b^+c^+d^+e^+; a^-b^-c^-d^+e^-)$ , hence should be considered as being of the same “type”. The sponge (a) appears in [41] as  $4^5(8)$ , but the sponge (b) is missing from that collection

## 7. NOTES AND COMMENTS

As noted earlier, an extension of the symbol  $(m, n, m + n)$  for helical rods to the case  $m = 0$  covers the stacked rods  $(3.3.3.3.3)_n$ . However, the very different properties of stacked rods as compared with helical rods make it reasonable to treat them separately. Analogously, the ribboned rods  $R(3.3.3.3.3)_n$  can be interpreted as helical rods  $(n, n, 2n)$ ; again, this is more of a sidelight than a contribution to understanding.

The study of helical rods developed from applications in biology. A detailed account was published by van Iterson [40] in 1907, although some

aspects were investigated even earlier. The work [40] concentrates on symmetrically arranged points situated on spirals that wind on cylinders. In particular, van Iterson studies (among more general kinds) point sets that can be used as centers of congruent balls, each of which touches six other balls. It is obvious that connecting the centers of such families of balls yields uniform helical rods. On the other hand, there are connections to the distribution of leaves or florets on various plants (phyllotaxis), to flagella of various bacteria, to subunits of certain microtubules, and various other biological entities; for details see Thompson [37] or Erickson [8]. Many other writers (mostly non-mathematicians) dealt with this topic; it is amusing that Alan Turing also studied this topic, see [39, pp. 141–144], and, in particular, [38].

The helical rods have a rich history. In particular, the smallest one –  $(1, 2, 3)$  in the notation of Section 3 – was repeatedly discovered by various workers; the name “tetrahelix” for it is reported to have been coined by R. Buckminster Fuller in [9]. As noticed by Hurley [24] and Coxeter [6], the tetrahelix can be obtained as a stack of regular tetrahedra, with adjacent tetrahedra related by reflection in the plane of the common face. Boerdijk [4] obtained it earlier, as a stack of regular tetrahedra related by screw-motion, as well as in the guise of a family of balls. He was not the first, as van Iterson [40] found the helical structures and the sphere packings in 1907. It is interesting that van Iterson credits (without explicit references) the tetrahelix of spheres (but not the other helices he investigates) to Federico Delpino; I was not able to determine which publication of Delpino’s led to the attribution.

Almost all uniform rods can be interpreted as resulting from suitable strips of uniform tilings of the plane. For the unary stacked and ribboned rods the square tiling and the tiling by triangles can be used, while binary ribboned rods and binary acoptic stacked rods require the (3.3.3.4.4) tiling.

A fine but non-obvious point needs to be mentioned; it is stressed (among others) by Erickson [8]. The often invoked picture (see Fig. 10 above) of the construction of uniform helical rods intimates that a suitable strip of the regular tiling (3.3.3.3.3) is bent into a cylinder. By this is meant that the vertices are placed on a cylinder, and the triangles are kept planar – so that the resulting rod *is not convex*. In particular, the equal length of the edges of the rod is *not compatible* with the assumption that each vertex is equally distant *in the geodesic distance on the cylinder* from all the adjacent vertices. Naturally, the vertices on each spiral are equidistantly disposed. Additional considerations of these matters can be found in Lord [25], where

also various related constructions that lead to symmetric (but not uniform) rods are described. Lord considers, in particular, isohedral structures with polygonal regions (such as hexagons) on cylinders, stressing their occurrence in biology and structural chemistry. Related information appears in [26].

**Note** (Added January 12, 2010). After the present paper was submitted, Dr. William T. Webber informed me that he has found an additional type of uniform rods with vertex symbol (3.3.3.3.3.3). In analogy to the situation concerning uniform slabs, these objects deserve to be called *crinkled rods*. Webber is preparing a paper with details of the construction of these rods.

## 8. RELATED POLYHEDRA-LIKE STRUCTURES

In this section we shall discuss various modifications of “uniform polyhedrals”; hence the word “polyhedral” and related expressions will be used without the implication of uniformity. The results mentioned here show that interesting geometry may result by considering polyhedrals more general than the uniform ones. It is my hope that the present exposition may lead to such investigations.

Helical triangle-faced polyhedrals (with not necessarily equilateral triangles as faces) have been studied by engineers in several contexts. Guest and Pelegriño [19] study the cases in which a given triangle leads to helical isohedral rods that can be collapsed to planar sets of triangles, with relatively small stresses (or deformations) during the transition from one configuration to another.

Raskin’s Ph.D. thesis [32] deals with deployable structures, that is, rods and slabs that can change their dimensions. These questions are addressed from an engineering point of view, but many of the examples are close to the topic of the present paper. For example, Figure 1.3 of [32] can be interpreted (in a manner not intended by Raskin) as a unary stacked rod  $(3^6)_8$ ; it is attributed to I. Hegedus [22]; Figure 1.6 could inspire the stacked rod  $(3^6)_3$ , but a better example is given by Miura [30]. Figure 3.39 in [32] can be interpreted as the ribboned rod  $R(3.3.3.3.3.3)_3$ , with triangles that are isosceles but not equilateral; it is attributed to You and Pellegrino [45]. Many other examples are given in [32], together with a wealth of references. Barker and Guest [1] describe several types of isogonal and isohedral rods

with triangular faces, and investigate buckling patterns that present some features of this kind.

In a different engineering application, Tarnai [36] describes the buckling of cylindrical shells as giving rise to isogonal stacked rods of type  $(3^6)_n$ , but with isosceles triangles; this is based on Miura [29]. He also presents cylindrical rods obtainable from the uniform tiling (3.3.4.3.4); these are not isogonal (there are two or more orbits of vertices) but the faces are planar polygons. Miura (in [29]) also describes analogues of isohedral acoptic stacked rods, with faces that are isosceles trapezes.

A very interesting deformable isohedral slab is described by Miura [30], see Fig. 22; it is meant to be employed in space structures such as arrays of solar cells. Suitable changes of the angle  $\alpha$  of bend along the ridges and valleys lead to a complete collapse. It may be noted that if the parallelograms are rhombi and  $\tau = 60^\circ$ , then the rhombi can be interpreted as pairs of equilateral triangles and the crinkle  $(3.3.3.3.3)_\alpha^\#$  shown in Fig. 14(a) is obtained. On the other hand, if the parallelograms are squares, and only the heavily drawn zigzags are taken as ridges and valleys (they are straight lines in this situation), then the corrugation  $(4.4.4.4)_\alpha$  shown in Fig. 12(a) results. However, Miura's claim that the parallelogram tiling "will fold into a point" is clearly wrong; a similar error occurs in [29]. The precise properties of the folding transformation still need to be investigated, in terms of the dependence on the angle  $\tau$  and on the ratio of the parallelogram sides. A partial analysis is given by Piekarski [31], who also considers variants that lead to curved structures.

From the facts mentioned above it is impossible to escape the conclusion that engineers, architects, biologists and others could have benefited from closer contact with mathematicians; even more evident is the fact that mathematicians could have been inspired in important ways by acquaintance with the works and problems in these applied disciplines. It should be borne in mind that the list of results mentioned here is very haphazard, since there is no reasonable way for a mathematician to access all of the relevant literature. The shocking failure in this matter of the reviewing journals (Math Reviews and Zentralblatt) is illustrated by the fact that almost none of the references we give – including the books [41] and [26], that clearly have mathematical importance and relevance – are even mentioned in either of these journals. Among the editorial policies of the refereeing journals there seems to be a deeply ingrained aversion to anything that has to do with the geometry of polyhedral objects in 3-space; this stand leads to a great loss to both pure and applied mathematics, and to culture in general.



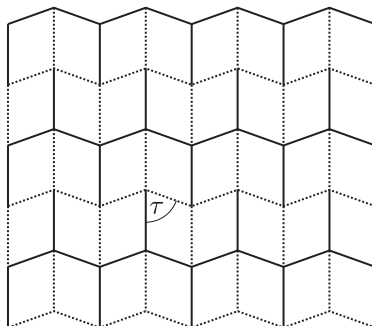

Fig. 22. An isohedral tiling by parallelograms, described by Miura [30]. It can be folded to yield a crinkled slab; heavy solid edges indicate ridges, dashed ones valleys

## REFERENCES

- [1] Barker, R. J. P. and Guest, S. D., Inflatable triangulated cylinders, in: *IUTAM-IASS Symposium on Deployable Structures: Theory and Applications*, S. Pellegrino and S. D. Guest, eds. Kluwer, Dordrecht 2000, pp. 17–26.
- [2] Bulatov, V., Uniform polyhedra.  
<http://bulatov.org/polyhedra/uniform/index.html>
- [3] Badoureau, A., Mémoire sur les figures isoscèles, *J. École Polytechn*, **30** (1881), 47–172.
- [4] Boerdijk, A. H., Some remarks concerning close-packing of equal spheres, *Philips Research Reports*, **7** (1952), 303–313.
- [5] Coxeter, H. S. M., Regular skew polyhedra in three and four dimensions, and their topological analogues, *Proc. London Math. Soc.* (2), **43** (1937), 33–62. Improved reprint in: *Twelve Geometric Essays*, Southern Illinois University Press, Carbondale IL, 1968. Reissued by Dover, 1999.
- [6] Coxeter, H. S. M., The simplicial helix and the equation  $\tan nt = n \tan t$ , *Canad. Math. Bull.*, **28** (1985), 385–393.
- [7] Coxeter, H. S. M., Longuet-Higgins, M. S. and Miller, J. C. P., Uniform polyhedra, *Philos. Trans. Roy. Soc. London (A)*, **246** (1953/54), 401–450.
- [8] Erickson, R. O., Tubular packings of spheres in biological fine structure, *Science*, **181** (1973), No. 4101, pp. 705–716.
- [9] Fuller, R. B., *Synergetics: Explorations in the Geometry of Thinking*, Macmillan, New York 1975, 1982.
- [10] Gillispie, S. B. and Grünbaum, B., The  $\{4, 5\}$  isogonal sponges on the cubic lattice, *Electronic J. Combinatorics*, **16** (2009), R22.

- [11] Goodman-Strauss, C. and Sullivan, J. M., Cubic polyhedra, *Discrete Geometry: in Honor of W. Kuperberg's 60th Birthday*, A. Bezdek, ed. Dekker, New York 2003, pp. 305–330.
- [12] Gott, J. R., III, Pseudopolyhedrons, *The American Mathematical Monthly*, **74** (1967), pp. 497–504.
- [13] Grünbaum, B., Regular polyhedra – old and new, *Aequationes Math*, **16** (1977), 1–20.
- [14] Grünbaum, B., Infinite uniform polyhedra, *Geombinatorics*, **2** (1993), 53–60.
- [15] Grünbaum, B., Metamorphoses of polygons, in: *The Lighter Side of Mathematics, Proc. Eugène Strens Memorial Conference*, R. K. Guy and R. E. Woodrow, eds. Math. Assoc. of America, Washington, D.C.. 1994 Pp. 35–48.
- [16] Grünbaum, B., “New” uniform polyhedra, in: *Discrete Geometry: In Honor of W. Kuperberg's 60th Birthday*, Monographs and Textbooks in Pure and Applied Mathematics, vol. 253. Marcel Dekker, New York, 2003. pp. 331–350.
- [17] Grünbaum, B., Miller, J. C. P. and Shephard, G. C., Uniform tilings with hollow tiles, “*The Geometric Vein – The Coxeter Festschrift*”, C. Davis, B. Grünbaum and F. A. Sherk, eds. Springer-Verlag, New York – Heidelberg – Berlin 1982, pp. 17–64.
- [18] Grünbaum, B. and Shephard, G. C., Incidence symbols and their applications, in: *Relations Between Combinatorics and Other Parts of Mathematics*, D. K. Ray-Chaudhuri, ed. Proc. Symposia Pure Math. vol. 34, pp. 199–244. Amer. Math. Soc., Providence, R.I., 1979.
- [19] Guest, S. D. and Pellegrino, S., The folding of triangulated cylinders. Parts I, II, *J. Applied Mechanics*, **61** (1994), 773–777 and 778–783.
- [20] Hart, G. W., Uniform polyhedra.  
<http://www.georgehart.com/virtual-polyhedra/uniform-info.html>
- [21] Hart, G. W., Archimedean polyhedra.  
<http://www.georgehart.com/virtual-polyhedra/archimedean-info.html>
- [22] Hegedus, I., Branching of equilibrium paths in a deployable column, *Internat. J. of Space Structures*, **8** (1993), 119–125.
- [23] Hughes Jones, R., Enumerating uniform polyhedral surfaces with triangular faces, *Discrete Math.*, **138** (1995), 281–292.
- [24] Hurley, A. C., Some helical structures generated by reflexions, *Austral. J. Physics*, **38** (1985), 299–310.
- [25] Lord, E. A., Helical structures: The geometry of protein helices and nanotubes, *Structural Chemistry*, vol. **13**, nos. 3/4 (2002), 305–314.
- [26] Lord, E. A., Mackay, A. L. and Ranganathan, S., *New Geometries for New Materials*, Cambridge Univ. Press, 2006.

- [27] Maeder, R., All uniform polyhedra.  
<http://www.mathconsult.ch/showroom/unipoly/list.html>
- [28] Miller, J. C. P., *On Stellar Constitution, on Statistical Geophysics, and on Uniform Polyhedra (Part 3: Regular and Archimedean Polyhedra)*, Ph.D. Thesis 1933. (Copy deposited in Cambridge University Library).
- [29] Miura, K., Proposition of pseudo-cylindrical concave polyhedral shells, *IASS Symposium on folded plates and prismatic structures*, Vol. 1, Vienna, 1970.
- [30] Miura, K., Concepts of deployable space structures, *International J. of Space Structures.*, **8** (1993), 3–16.
- [31] Piekarski, M., Constructional solutions for two-way-fold-deployable space trusses, *IUTAM-IASS Symposium on Deployable Structures: Theory and Applications*, S. Pellegrino and S. D. Guest, eds. Kluwer, Dordrecht, 2000, pp. 301–310.
- [32] Raskin, I., *Stiffness and stability of deployable pantographic columns*, PhD thesis in Civil Engineering, University of Waterloo, 1998.
- [33] Skilling, J., The complete set of uniform polyhedra, *Philos. Trans. Roy. Soc. London (A)*, **278** (1975), 111–135.
- [34] Sopov, S. P., Proof of the completeness of the enumeration of uniform polyhedra [in Russian], *Ukrain. Geom. Sbornik*, **8** (1970), 139–156.
- [35] Szepesvári, I., On the number of uniform polyhedra. I, II. [in Hungarian], *Mat. Lapok*, **29** (1977/81), 273–328.
- [36] Tarnai, T., Folding of uniform plane tessellations, *Origami Science and Art. Proc. of the Second Int. Meeting of Origami Science and Scientific Origami, Otsu, Japan, 1994* (ed.: K. Miura), Seian Univ. of Art and Design, 1997, 83–91.
- [37] Thompson, D'A. W., *On Growth and Form*, Cambridge Univ. Press, 1948.
- [38] Turing, A. M., The chemical basis of morphogenesis, *Philos. Trans. Roy. Soc. London, Ser. B*, **237** (1952), 37–72. Reprinted, together with previously unpublished manuscripts, in *Morphogenesis*, Collected Works of A. M. Turing, P. T. Saunders, ed. North-Holland, Amsterdam, 1992.
- [39] Turing, S., *Alan M. Turing*, W. Heffer & Sons, Cambridge, 1959.
- [40] van Iterson, G., Jun., *Mathematische und mikroskopisch-anatomische Studien über Blattstellungen, nebst Betrachtungen über den Schalenbau der Miliolinen*, Gustav Fischer, Jena, 1907.
- [41] Wachman, A., Burt, M. and Kleinmann, M., *Infinite Polyhedra*, Technion, Haifa 1974; reprinted 2005.
- [42] Weisstein, E. W., “Uniform Polyhedron.” From *MathWorld* – A Wolfram Web Resource. <http://mathworld.wolfram.com/UniformPolyhedron.html>

- [43] Wikipedia, List of uniform polyhedra.  
[http://en.wikipedia.org/wiki/List\\_of\\_uniform\\_polyhedra](http://en.wikipedia.org/wiki/List_of_uniform_polyhedra)
- [44] Wikipedia, Expanded list of uniform tilings.  
[http://en.wikipedia.org/wiki/Uniform\\_tiling#Expanded\\_lists\\_of\\_uniform\\_tilings](http://en.wikipedia.org/wiki/Uniform_tiling#Expanded_lists_of_uniform_tilings)
- [45] You, Z. and Pelegriño, S., Cable-stiffened pantographic deployable structures. I. Triangular mast, *AIAA Journal*, vol. **34**, no. 4 (1996), 813–820.

Branko Grünbaum

Address: ? 

e-mail: ??? 