

EE 215 - Laboratory 4 - First Order Circuits

Authors

R.D. Christie

Objectives

At the end of this lab, you will be able to:

- Confirm the steady state model of capacitors and inductors
- Determine time constants from observed data
- Determine inductance from time response
- Use an op amp as a comparator
- Design time delay circuits using RC time constants

Materials and Supplies

See Laboratory 1 for information on obtaining a laboratory parts kit and multimeter, and for identifying many of the parts used in Laboratory 4.

Parts for This Lab

The only new part used in this lab is the Single Pole Double Throw (SPDT) switch. Single Pole means that there is only one moving switch arm. Double Throw means that the arm can connect to two different nodes. Figure 1 shows the circuit symbol for an SPDT switch.

The switch is a black rectangular slide switch with three prongs. The prongs fit into breadboard holes. When the slide knob is at one end of the switch, the center prong is connected to the prong at that end, and the prong at the other end is unconnected (an open circuit).

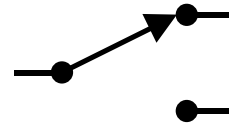

Figure 1 - SPDT Switch Circuit Symbol

Laboratory Procedures, Measurements and Questions

Record your data and the answers to questions on a separate sheet (or sheets) of paper and hand it in at recitation section when the lab is due. You will also have to bring your breadboard with designated circuits on it to your recitation section the week the lab is due.

Procedure 1: RC Circuit (30 points)

Construct the circuit of Figure P1-1.

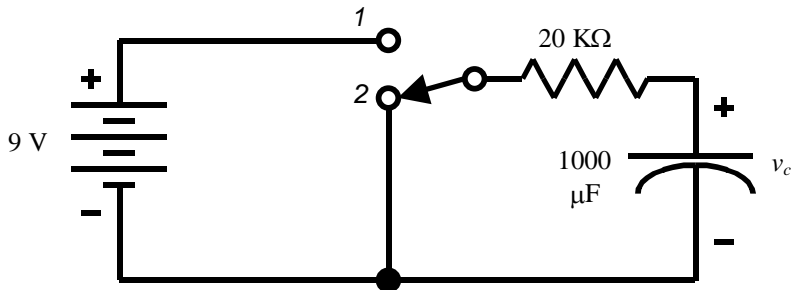

Figure P1-1 RC switched circuit.

Note: Check that the electrolytic capacitor in this circuit is connected with the correct polarity. The negative lead is the short one, marked "-" on the side of the capacitor package.

1.a (3 points) Compute the value of capacitor voltage v_c if the switch is in the down position (2) for a long time. Measure v_c and compare to your computed value. How long is "a long time" for this circuit?

1.b (2 points) Compute the value of v_c if the switch is in the up position (1) for a long time. Use the measured value of the battery voltage. Measure v_c and compare.

1.c. (15 points) Prepare to write down the value of v_c every 15 seconds. This is easiest using alligator clips and monitoring voltage continuously. After the switch has been in the up position (1) for a long time, switch it to the down position (2) and simultaneously start timing. (For example, throw the switch when the second hand on a watch is at zero seconds, or at the same time as the stopwatch feature on a digital watch is started.) Record the value of v_c every 15 seconds for three minutes. Graph the voltage values. Characterize the graph - is it linear, quadratic, or exponential? Determine the circuit time constant from the graph. Calculate the ideal time constant using nominal component values. Find the % error between the ideal and measured values.

1.d. (10 points) After the switch has been in the down position (2) for a long time, switch it to the up position (1) and record a value of v_c every 15 seconds for three minutes. Graph the voltage values. Characterize the graph - is it linear, quadratic, or exponential? Determine the circuit time constant from the graph. Calculate the ideal time constant using nominal component values. Find the % error between the ideal and measured values.

Hint: There are a variety of methods for determining the time constant from a graph of time response. These include:

- Drawing a tangent to the response at $t = 0$. This intersects the final steady state value at the time constant τ . While fine for ideal circuits, the rapid change at $t = 0$ can produce a lot of error in the calculation for actual circuits.
- Solving the equation of the response using two points from the response curve. Suppose the response is of the form $v = Ae^{-t/\tau}$. Choose two points where v and t are known, and solve for A and τ . The points can be chosen to minimize error, typically at 90% and 10% of total response. For example, if the initial voltage was 10V and the final voltage was 0, points with voltages near 9V and 1V would be used. Note that A can be eliminated by dividing the equations for the two points.

Procedure 2: RL Circuit (30 points)

2a. (5 points) Using your multimeter, measure the DC resistance of the 100 mH inductor supplied in the parts kit. Draw a model for the real inductor that includes this resistance. Compute the maximum time constant for this component. Do you think you could see the change of current with time with your multimeter?

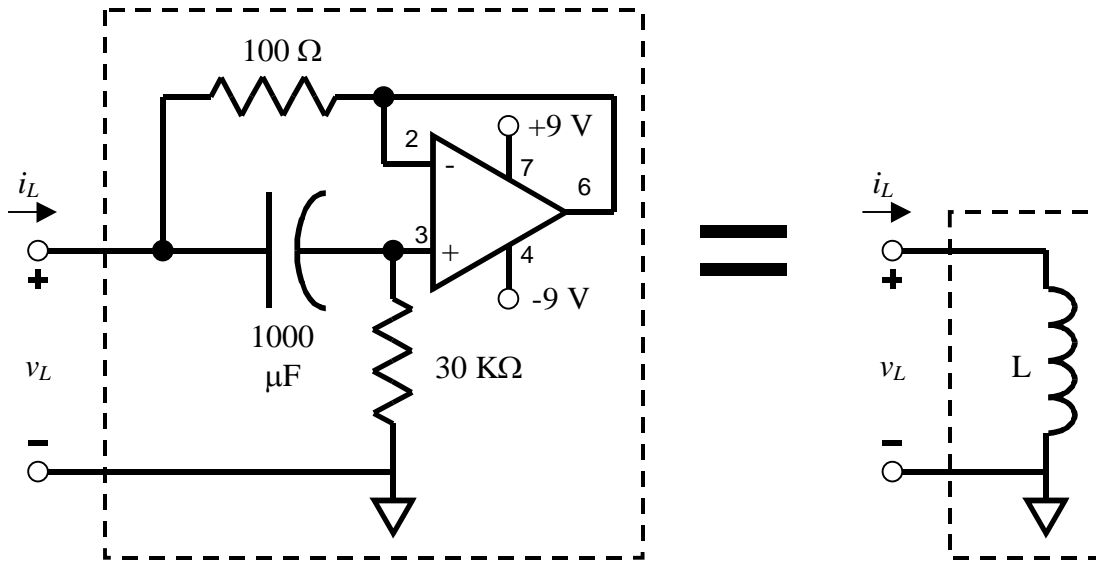

Figure P2-1 Simulated inductor circuit

An inductor time constant long enough to see with a multimeter requires a very large, heavy and expensive inductor. The problem of inductor size also challenges integrated circuit designers. It is very difficult to put an inductor into an integrated circuit. Fortunately, there is an op amp circuit called a simulated inductor, which uses an op amp, two resistors and a capacitor to produce a branch relationship similar to an inductor. The circuit is shown in figure P2-1. Don't worry too much about how it works, just build it! (Although you should have the tools to figure out how it works. Think of this as a challenge.)

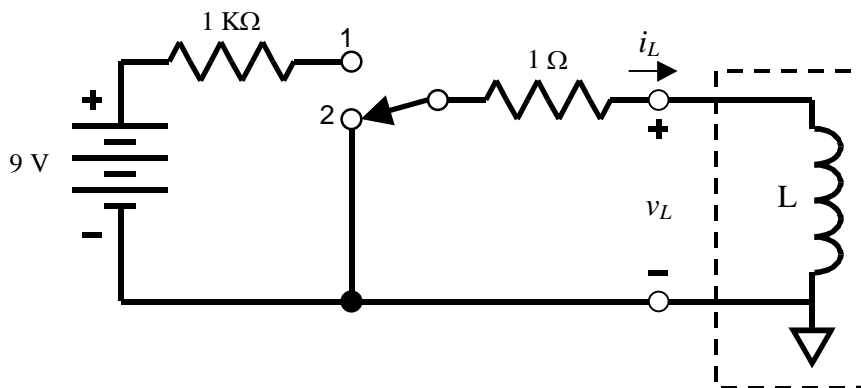

Figure P2-2 RL switched circuit.

2.b (25 points) (i) Build the circuit of Figure P2-2 using the simulated inductor you built in step 2a. Note that the battery in P2-2 is also the +9V supply for the op amp. Set up to monitor inductor current, either directly with your

multimeter or by observing the voltage across the $1\ \Omega$ resistor. (Use the measured resistance value of the $1\ \Omega$ resistor for current calculations.) Check that the switch is in the down position (2) before energizing the circuit (including the op amp).

Note: Simulated inductors have some limitations. First, one terminal has to be at the neutral, (the - terminal in figure P2-2) which limits the types of circuits that can be created (but is fine for us). Second, op amp saturation limits the range of response. Third, there can be initialization issues. Also, problems getting the simulated inductor to work are often due to the op amp power supply. Remember that the +9V and -9V supplies are with reference to the neutral, or ground, node, so the 9V batteries must be connected at one end to the ground node. See Lab 3 for a circuit diagram showing specific power supply connections.

(ii) Monitor the inductor current with the switch in the down position (2) until it is less than 7 mA. Then move the switch to the up position (1).

(iii) After the switch has been in the up position (1) long enough for inductor current to stabilize (be constant), measure and record the inductor current and voltage. Compute the DC resistance of the inductor.

(iv) Now move the switch to the down position and record the value of i_L every 15 seconds for three minutes. Graph the current values. Characterize the graph - is it linear, quadratic, or exponential? Determine the circuit time constant from the graph. Determine the inductance of the simulated inductor from the time constant, the resistors in the circuit, and the internal resistance of the inductor measured in step 2.b.(iii).

Procedure 3 Design with Time Constants (40 points)

Many systems are designed to have actions occur after a time delay. Consider a car alarm, for example, that senses motion by closing a switch. If the alarm goes off the instant the switch is closed, there would be a lot of false alarms. On the other hand, once the alarm is on, it should stay on for some time after the motion stops and the switch opens, to encourage the bad guys to leave.

In this design, the manual switch will simulate the motion sensor. (A real motion sensor would probably make intermittent contact while moving, while the manual switch will stay open or closed when switched, so the manual switch is an approximation.) Most switch-type sensors are single throw, that is, they are either open or closed, rather than having two contacts like the manual switch in the lab kit. That's because SPST is cheaper than SPDT. You can use the lab kit SPDT switch as an SPST switch by not connecting one of the contacts.

The part of the car alarm will be played by a comparator circuit (Figure P3-1). A comparator compares two voltages (hence the name). If the first voltage is higher than the second, the comparator output saturates high, near $+V_{cc}$. If the second voltage is higher than the first, the comparator output saturates low, near $-V_{cc}$. Thus the comparator converts an analog voltage (one that can take on an infinite number of values) into a digital one (high or low, 1 or 0, on or off). A comparator is a simple form of analog-to-digital converter (ADC).

3.a. (5 points) Construct the circuit of figure P3-1. Adjust the 100 K Ω pot to vary V_- . Adjust the 10 K Ω pot to vary v_{in} . Complete Table P3-1.

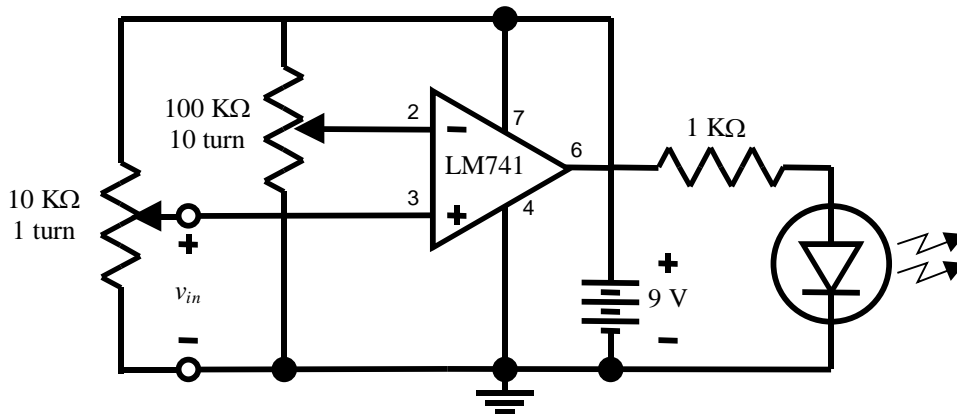

Figure P3-1 Comparator Circuit.

Table P1-1 Comparator Test Results

V_-	v_{in}	Expected LED State	Observed LED State
3.0 V	2.9 V		
3.0 V	3.1 V		
6.0 V	3.1 V		
6.0 V	8.0 V		

Turn v_{in} all the way down to 0 V, and lower V_- until the LED turns on. Measure and record the value of V_- . Compare to v_{in} . This is the low limit of comparator sensitivity.

Turn v_{in} all the way up to battery voltage and raise V_- until the LED goes out. Measure and record the value of V_- . This is the high limit of comparator sensitivity.

3.b. (30 points)

Design a car alarm time delay circuit to the following requirements:

- The output of your time delay circuit will be the input (v_{in}) to the comparator circuit of step 3.a. Replace the 10 K Ω potentiometer with your time delay circuit. You may choose a value for the comparator voltage setpoint and use the 100 K Ω potentiometer to set it. (In a real design you would of course use a voltage divider for this function, but this design focuses on the time constants.)
- The "alarm" in this design is the LED. When it is brightly lit, the alarm is on. When the LED is dark, the alarm is off.
- The input to your circuit is a 9V battery in series with a SPST switch.
- When the switch has been open for a long time, and is closed, there should be a 10 second delay before the alarm picks up (turns on).
- When the switch has been closed for a long time, and then opened, there should be a 4 second delay before the alarm resets (turns off).
- Use parts from your lab kit for the design.

Submit the circuit diagram of your design with all values noted. (The comparator can be shown as a block diagram. However, note the comparator voltage setpoint). Also submit design calculations showing how you arrived at your component values.

c. (5 points) Implement your design on your breadboard. Measure and record the on and off times you obtained. Show the working circuit to your TA.

NOTE: If you do not show your TA your circuit from part c, your grade for this procedure is zero.