

EE 215 - Laboratory 2 - Nodal Analysis and Thévenin Equivalents

Authors

D. Wilson, R.D. Christie, W.R. Lynes, K.F. Böhringer, M. Ostendorf

Objectives

At the end of this lab, you will be able to:

- Construct, analyze and measure multiple-source circuits
- Model transistors as dependent sources, and confirm the model with measurements
- Develop Thévenin equivalent models of real world components (a potato battery!)
- Design an experiment to determine a Thévenin equivalent model (of a diode)

Materials and Supplies

See Laboratory 1 for information on obtaining a laboratory parts kit and multimeter, and for identifying many of the parts used in Laboratory 2.

Parts for This Lab

For parts (or, types of parts, like resistors) that you have already used in Lab 1, you should be able to pick the parts out from the circuit diagram and find them in your part kit. This section will discuss parts you have not worked with yet. These are:

- A raw potato (no kidding!)
- Copper and tin (galvanized) nails
- Red Light Emitting Diode (LED)
- Bipolar Junction Transistor (BJT), NPN, 2N3904

The *potato* is NOT supplied in the parts kit, and should be purchased from a grocery store. It provides the electrolyte for a peculiar form of battery. The *copper and tin (galvanized) nails*, form the electrodes of the battery. You could buy these from a home improvement store, but for your convenience they are supplied in the parts kit.

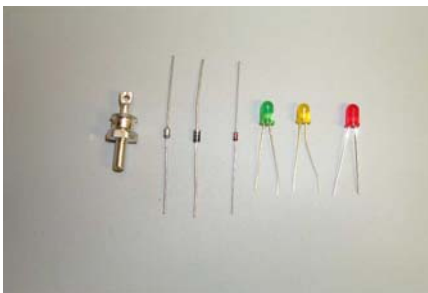

Figure 1 - Types of diodes. The three on the right are Light Emitting Diodes (LEDs). The one on the left is a power diode. To the right is the diode circuit symbol, with A and K on the anode and cathode.

Light Emitting Diodes or LEDs (Figure 1) are the colored plastic bullet-shaped parts with two parallel leads sticking out the back of the bullet.

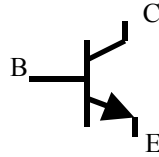

Figure 1 - Types of transistors. The left hand lower one is the one in the lab kit. The large square ones and the large metal cans are power transistors. An NPN transistor circuit symbol, with Collector, Base and Emitter marked C, B and E respectively, is on the right side of the figure.

The *transistor* is the small black plastic part with three leads coming out. The case is shaped like a cylinder with one side shaved flat. If you look closely you can find its model number, 2N3904, printed on the flat side.

Laboratory Procedures, Measurements, and Questions

Record your data and the answers to questions on a separate sheet (or sheets) of paper and hand it in at recitation section when the lab is due. You will also have to bring your breadboard with designated circuits on it to your recitation section the week the lab is due.

Procedure 1 (25 points) Node and Mesh Analysis, Thévenin Equivalent

Construct the circuit of Figure P1-1 on your breadboard:

a. (5 points) Calculate the voltage v across the $20\text{ k}\Omega$ resistor using node voltage analysis.

b. (5 points) Calculate the current i through the $20\text{ k}\Omega$ resistor using mesh current analysis.

c. (5 points) Measure the voltage v across the $20\text{ k}\Omega$ resistor. Measure the current i through the $20\text{ k}\Omega$ resistor. Are these values consistent with your calculations in parts a and b? Explain any differences. (Remember to return your meter to voltage measurement or off as soon as you have completed the current measurement.)

d. (5 points) Compute the values of the Thévenin equivalent seen by the $20\text{ k}\Omega$ resistor using circuit analysis techniques. Draw the equivalent circuit and list the values.

e. (5 points) Remove the $20\text{ k}\Omega$ resistor from the circuit you built and measure the open circuit voltage v . Replace the $20\text{ k}\Omega$ resistor with a short circuit (your multimeter set on current works nicely) and measure the short circuit current i . Use these values to compute a Thévenin equivalent. Compare to the Thévenin equivalent from part e.

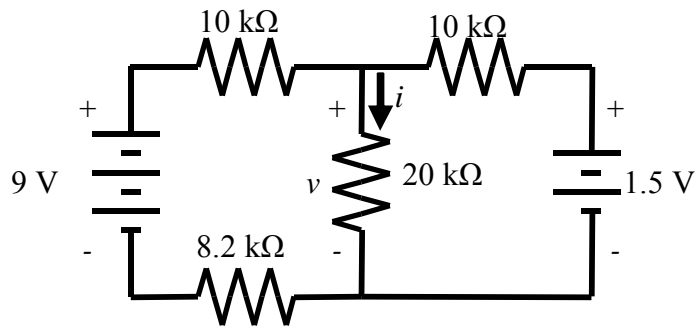

Figure P1-1 - Procedure 1 Circuit

Procedure 2 (25 points) Thévenin Equivalents as Models

Computing Thévenin equivalents is easy when the circuit components have known values. Computing equivalents from measured values is easy when open circuit voltage and short circuit current is available. What about components with unknown quantities, that should not be short circuited? That's what this procedure covers.

Ideal voltage sources have zero internal resistance ($R_{eq} = 0$) but real voltage sources have non-zero internal resistance. For many applications, the non-zero resistance is important. In this procedure you will determine internal resistance by finding Thévenin Equivalent circuits for two real voltage sources, a 1.5V AA battery and a potato. Pay attention to the values of R_{eq} !

a. (5 points) Connect a 100 Ω resistor and the 1.5 V AA battery as shown in Figure P2-1. Measure the open circuit voltage and the short circuit current at the circuit terminals, marked a and b in Figure P21. Do NOT short circuit the battery all by itself, i.e. always have the 100 Ω resistor in the circuit. If you like, you can find current by measuring the voltage across the resistor and applying Ohm's Law. This is a safer way of measuring current than using an ammeter. If you do this, consider whether you should use the nominal or measured value of the resistance.

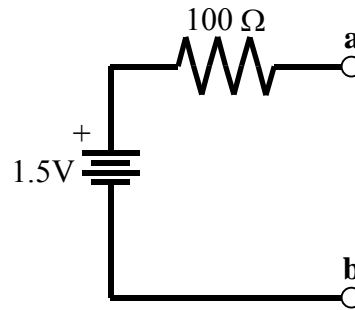

Figure P2-1 - Battery circuit

b. (5 points) Using the measurements made in part a, calculate the Thévenin Equivalent circuit for the battery and series resistor taken together. Then calculate the internal resistance of the battery. Draw the Thévenin Equivalent of the battery, only. Label values.

c. (5 points) Stick a piece of zinc (the galvanized nail is zinc coated onto iron) into one end of your raw potato and a piece of copper (the copper nail, although a penny will work) into the other end. Connect a 100 Ω resistor in series with the potato. (Alligator clips help here.) Measure the open circuit voltage and short circuit current at the circuit terminals.

d. (5 points) Calculate and draw the Thévenin Equivalent circuit for the potato battery without the 100 Ω resistor.

e. (5 points) Which is a better battery, and why?

Note: I would not eat the potato after using it in this experiment.

Procedure 3 (25 points) Dependent Sources

Unlike resistors or capacitors, you can't buy a dependent source off the shelf. At least, not a cheap one. However, dependent sources are the basis of models for important electronics components, like the Bipolar Junction Transistor (BJT). In this procedure, you will determine the parameters (current gain, β , and base-to-emitter voltage v_{BE}) of a dependent source model for a BJT.

A BJT has three connections, which appear as pins emerging from the transistor package. They are the *collector*, *emitter* and *base*. A simple model of the BJT is that current flow into the base controls the current flow between the collector and emitter. Thus a Current Controlled Current Source (CCCS) can be used as a model. The base is connected to the emitter through a voltage source, v_{BE} . Figure P3-1 shows the transistor package pins, the transistor circuit symbol, and the CCCS model.

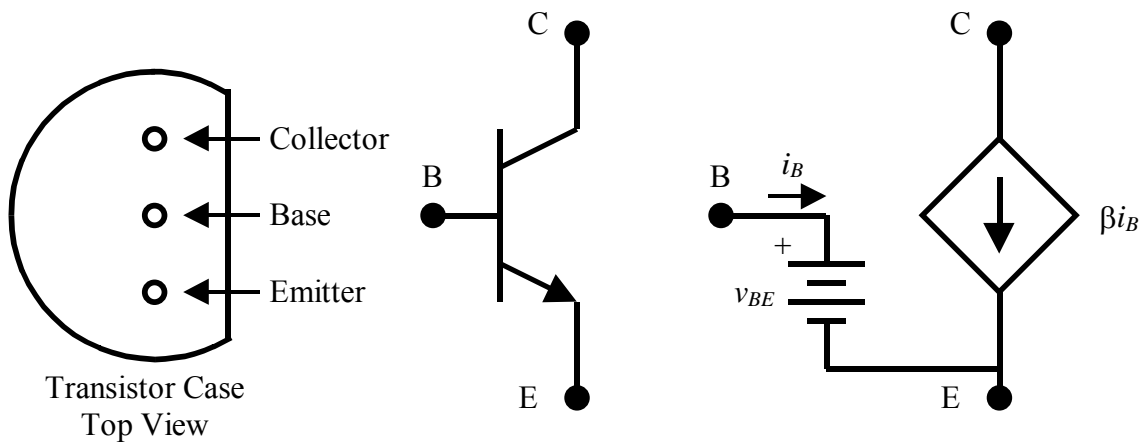

Figure P3-1 - Three different representations of the same NPN Bipolar Junction Transistor (BJT). On the left, the transistor case viewed from the top, with the Collector, Base and Emitter leads identified. In the center, the transistor circuit symbol. On the right, the Current Controlled Current Source (CCCS) model of the transistor.

As with most models, this model is valid over a restricted range of operation. A transistor cannot manufacture current or voltage by itself. If the power supply behind the collector pin cannot supply enough current or voltage to overcome resistance of the circuit on either side of the transistor the model above fails to represent the transistor accurately. If collector-to-emitter voltage $v_{CE} < v_{BE}$, this model is also inaccurate.

a. (5 points) Construct the circuit of figure P3-2 using the bipolar junction transistor (BJT). Adjust the trim pot to obtain a voltage between the collector and emitter of the transistor, v_{CE} , of approximately 5 volts Measure and record the battery voltage, the voltage across

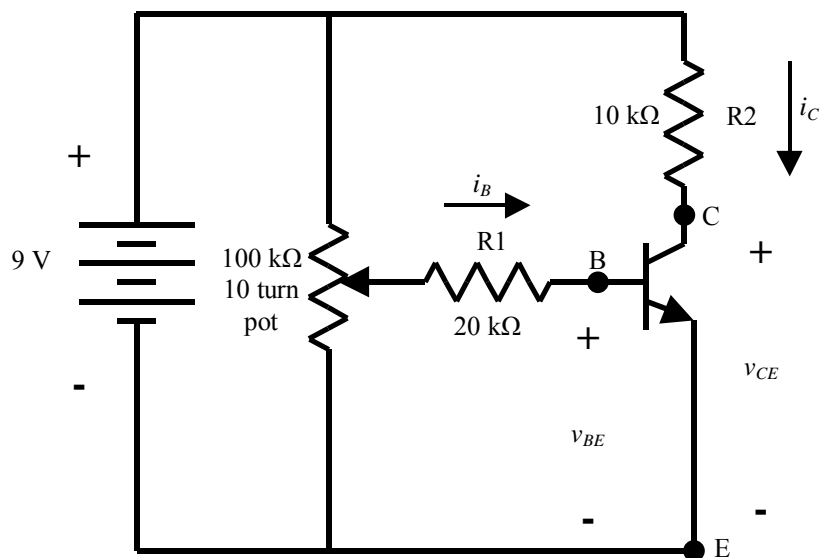

Figure P3-2 Transistor circuit.

the 20 k Ω resistor R1, the voltage across the 10 k Ω resistor R2, the voltage between the base and emitter of the transistor, v_{BE} , and the voltage between the collector and emitter of the transistor, v_{CE} . Calculate the currents passing through R1 and R2, i_B and i_C , respectively, from the voltages measured in part a, and Ohm's Law.

Hint: The 10 turn pot is the long rectangular one. Mount it on the breadboard so the adjustment screw is close to one end of the board.

b. (5 points) Use the results of part a to compute the parameters of the CCCS model for the transistor, v_{BE} and current gain β .

c. (5 points) Redraw the circuit replacing the transistor with the CCCS model, using the parameters computed in part b. (Don't worry about the potentiometer setting in your drawing.)

d. (5 points) Assume the potentiometer is set so base current $i_B = 3.50 \mu\text{A}$. Find the voltage across R1 for this base current. Calculate the collector-emitter voltage v_{CE} from the circuit of part c for this base current. In the physical circuit, adjust the potentiometer to obtain the voltage across R1 you just computed. Measure the voltage from the transistor emitter to collector, v_{CE} . Compare the computed and measured values. Comment on differences.

e. (5 points) Look up the data sheet for the 2N3904 transistor by searching for the part number on the Web. Compare your values of β and v_{BE} to those in the data sheet. (Note: β may appear as h_{FE} in the data sheet.) Comment on differences.

Procedure 4 (25 points) Experiment Design

In this procedure, you get to write and execute an experimental procedure to find a Thévenin equivalent model for a Light Emitting Diode (LED).

The simplest model for a diode is as a switch that is on (short circuit) when current tries to flow in the direction of the arrow in the diode symbol, and off (open circuit) when the current tries to flow in the direction opposite to the arrow. This model doesn't work all that well for an LED because the LED emits more light as the current passing through it increases. The light requires power, and short circuits do not model power dissipation. So we need a model with a resistance and/or source to dissipate the power that goes into the light. A resistance and a voltage source is a Thévenin Equivalent.

a. (20 points) Write an experimental procedure to determine a Thévenin equivalent model for an LED that is in the On (light emitting) state. Include a circuit diagram and the steps of your procedure.

b. (5 points) Execute your procedure, and determine the parameters of your model. Draw a circuit diagram of your model with the parameters. Check your model against measured values. Check your model when the diode is in the off state. Comment on how good a model you have. Bring the circuit you used to find the model to class and show it to your TA.

NOTE: If you do not show your circuit to your TA, you will get a zero on this Procedure.

A few possibly helpful remarks:

The LED leads are indicated by both the length of the leads and the flat spot on the rim of the diode. The short lead is next to the flat spot, and is the cathode (K), the lead at the head of the arrow, which is also the end of the diode symbol with the bar (Figure P4-1). The long lead, the one further from the flat spot, is the anode (A), the lead at the tail of the arrow of the diode symbol. The diode will allow current to flow from the anode to the cathode.

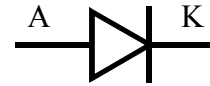

Figure P4-1 Diode circuit symbol

As the voltage v_{AK} from anode to cathode is slowly increased from 0 to 2.0 V, the LED will glow dimly and then suddenly become much brighter. This sudden transition marks the turn-on point of the diode, called the threshold voltage. The model you are looking for is for the On state, i.e. for values of v_{AK} greater than the threshold.

It's a bad idea to have the diode across the battery by itself. It WILL burn out. Keep at least a 1 k Ω resistance in series with the diode.