

Provided for non-commercial research and education use.  
Not for reproduction, distribution or commercial use.

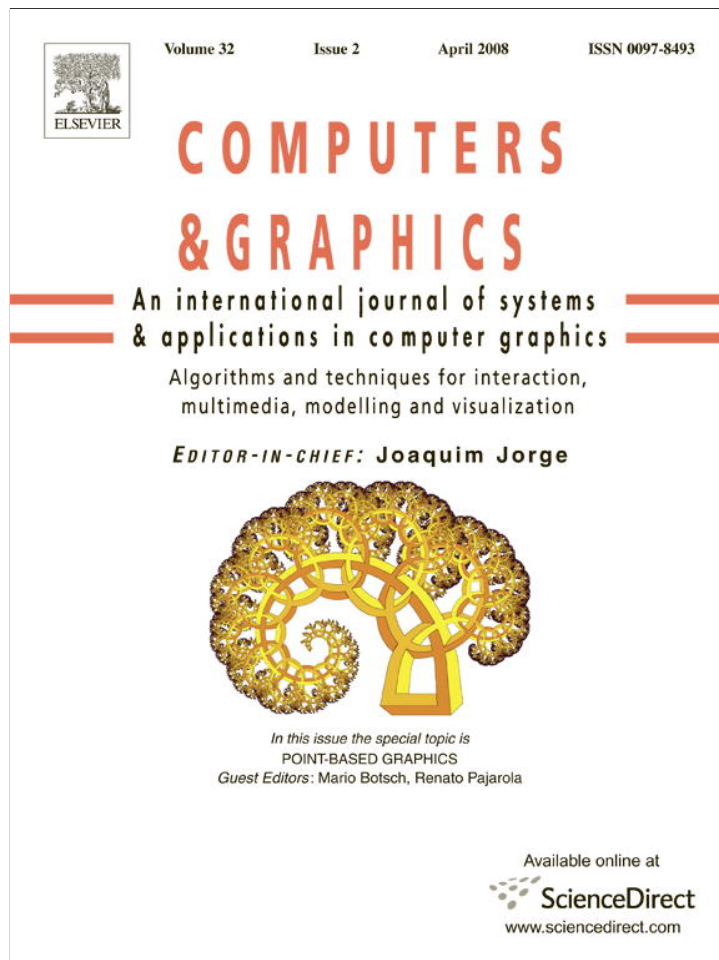

This article appeared in a journal published by Elsevier. The attached copy is furnished to the author for internal non-commercial research and education use, including for instruction at the authors institution and sharing with colleagues.

Other uses, including reproduction and distribution, or selling or licensing copies, or posting to personal, institutional or third party websites are prohibited.

In most cases authors are permitted to post their version of the article (e.g. in Word or Tex form) to their personal website or institutional repository. Authors requiring further information regarding Elsevier's archiving and manuscript policies are encouraged to visit:

<http://www.elsevier.com/copyright>



Education

## Fast ray tracing and the potential effects on graphics and gaming courses

Peter Shirley<sup>a</sup>, Kelvin Sung<sup>b,\*</sup>, Erik Brunvand<sup>a</sup>, Alan Davis<sup>a</sup>,  
Steven Parker<sup>a</sup>, Solomon Boulos<sup>a</sup>

<sup>a</sup>University of Utah, USA<sup>b</sup>University of Washington, Bothell, WA98011-8246 USA

Received 18 September 2007; accepted 21 January 2008

---

**Abstract**

The modern graphics processing units (GPUs), found on almost every personal computer, use the z-buffer algorithm to compute visibility. Ray tracing, an alternative to the z-buffer algorithm, delivers higher visual quality than the z-buffer algorithm but has historically been too slow for interactive use. However, ray tracing has benefited from improvements in computer hardware, and many believe it will replace the z-buffer algorithm as the graphics engine on PCs. If this replacement happens, it will imply fundamental changes in both the API to and capabilities of 3D graphics engines. This paper overviews the backgrounds in z-buffer and ray tracing, presents our case that ray tracing will replace z-buffer in the near future, and discusses the implications for graphics oriented classes should this switch to ray tracing occur. Since computer gaming is one of the most important industry driving graphics hardware and the fact that recently there are many computer science courses related to games and games development, we also describe the potential impact on games related classes.

© 2008 Elsevier Ltd. All rights reserved.

PACS: K.3.2

*Keywords:* Ray tracing; z-Buffer; Curriculum; Graphics courses; Computer gaming

---

**1. Introduction**

At present almost every personal computer has a dedicated processor that enables interactive 3D graphics. These graphics processing units (GPUs) implement the *z-buffer* algorithm introduced in Catmull's landmark University of Utah dissertation [1]. These GPUs can interactively display several million triangles with texture and lighting. The wide availability of GPUs has revolutionized how work is done in many disciplines, and has enabled the hugely successful video game industry. While the hardware implementation of the z-buffer algorithm has allowed excellent interactivity at a low cost, there are three

classes of applications that have not significantly benefited from this revolution:

- those that have data sets much larger than a few million triangles;
- those that have non-polygonal data not easily converted into triangles;
- those that demand high quality shadows, reflection, and refraction effects.

These classes of applications typically use Whitted's ray tracing algorithm [2–4] or Cook's distribution ray tracing (DRT) algorithm which is an order of magnitude more expensive than simple Whitted ray tracing but allows many advanced visual effects (Fig. 1). The ray tracing algorithm is better suited to huge data sets than the z-buffer algorithm because it creates an image in time sub-linear

\*Corresponding author.

E-mail address: [ksung@u.washington.edu](mailto:ksung@u.washington.edu) (K. Sung).

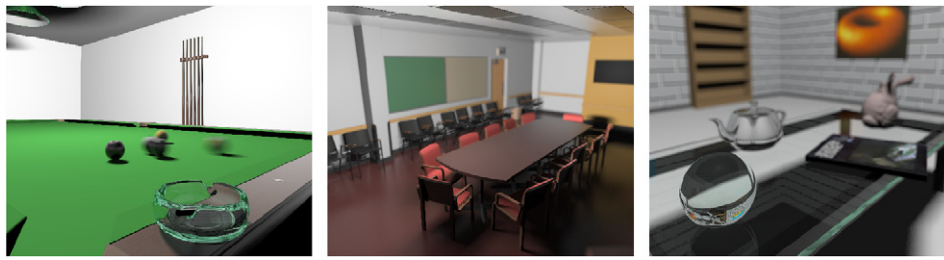

Fig. 1. Ray tracing can robustly and naturally support next generation visual effects not easily combined with GPU graphics including depth-of-field, motion blur, glossy and specular reflection, soft shadows, and correct refraction. More details on the system that generated of these images are available in [5].

in the number of objects while the z-buffer is linear in the number of objects. It is ray tracing's larger time constant and lack of a commodity hardware implementation that makes the z-buffer a faster choice for data sets that are not huge. Ray tracing is better suited for creating shadows, reflections, and refractions because it directly simulates the physics of light. Ray tracing enables these forms of isolated visibility queries that are problematic (or impossible) for the z-buffer algorithm. Ray tracing also allows flexibility in the intersection computation for the primitive objects that allows non-polygonal primitives such as splines or curves to be represented directly. Unfortunately, computing these visual effects based on simulating light rays is computationally expensive, especially on a general-purpose CPU. The ray tracing algorithm currently requires tens to hundreds of CPUs to be interactive at full-screen resolution.

Games have driven almost all desktop 3D graphics, and we believe that trend will continue. Because ray tracing is well-suited to support a quantum leap in the ability of games to support higher-order surfaces, complex models, and high quality lighting, we believe games will migrate to using it once ray tracing is fast enough. In this paper we argue that it is feasible to make ray tracing fast enough, and that this implies that migration will take place. Because such a migration implies a basic change of algorithm, it will have major effects on both future graphics and games related courses. The main purposes of this paper are to analyze these issues and examine how courses related to graphics and games might be effected.

Another reason we think ray tracing should have more of a place in computer graphics classes is that academics are well ahead of industry in ray tracing research. This enables an instructor to make the students feel like they are "in the club" in a way that their cohorts in industry are not. It becomes increasingly difficult to convince a college-age student that they can learn things in the academic environment that are unavailable in industry, it is important to take advantage of such opportunities and ray tracing presents a major one.

We first give an overview of the z-buffer algorithm found in GPUs, and contrasts this with the ray tracing algorithm. We then argue, in detailed, why we believe ray tracing is coming to the desktop, and probably sooner than is

commonly believed. Finally, we discuss what the implications of this change are for graphics and games education.

## 2. Ray tracing versus rasterization

In this section we review the ray tracing and z-buffer algorithms, the applications that use them, the performance such applications demand, and the various ways such performance might be delivered.

Current GPUs are based on the z-buffer [1] which is a straightforward algorithm. In hardware implementations it typically has two frame buffers; one for color and one for  $z$  (depth) values. While computing one of the color buffers (the "back" buffer), it displays the other (the "front" buffer). When all of the colors are computed in the back buffer, the two buffers are "swapped" (the front becomes the back and vice versa) and the new set of colors are displayed. The z-buffer is only used while computing the new colors in the back buffer. Computing the back buffer is a loop over all triangles:

initialize all pixel colors to *background color*

initialize all pixel  $z$  values to  $\infty$

**for all**  $N$  triangles **do**

**for each** pixel  $p$  that triangle might be seen through **do**

        compute color  $c_{new}$  and depth  $z_{new}$

**if**  $z_{new} < z_p$  **then**

$c_p = c_{new}$

$z_p = z_{new}$ .

The *if* statement is how the hidden surface elimination remains simple; overlapping polygons settle their order by means of storing the closest depth value seen so far in the triangle loop. This algorithm's runtime is proportional to the number of triangles  $N$ . While the algorithm can be made sub-linear through occlusion culling [6], randomized culling [7], and by level-of-detail management [8], these techniques add complexity and data restrictions to the implementations.

The z-buffer algorithm has difficulty in three main areas: rendering images with shadows and mirror-like reflections and refractions, rendering images with extremely large data sets, and rendering images with primitives that are not

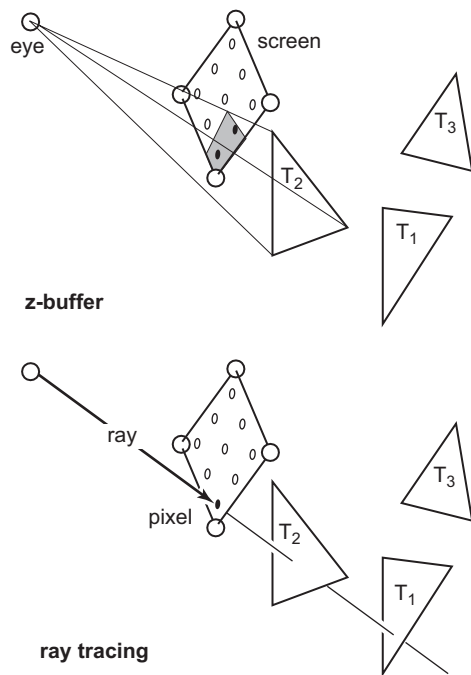

Fig. 2. Top: the z-buffer algorithm projects a triangle toward the nine pixel screen and writes all pixels with the distance to the eye (the “z” value) and its color unless a smaller distance is already written in the z-buffer. Bottom: the ray tracing algorithm sends a 3D half-line (a “ray”) into the set of objects and finds the closest one. In this case the triangle  $T_2$  is returned.

simple triangles. The ray tracing algorithm loops over pixels rather than objects:

```

for all  $P$  pixels do
    find the nearest object seen through that pixel.
    
```

This loop “finds the nearest object” by doing a line query in 3D (Fig. 2). Some implementations do “double-buffering” like the z-buffer above, but the algorithm above is inherently “frameless” in that a pixel can be immediately updated when computed. Frameless implementations have some advantages in responsiveness [9–11], and are problematic for the z-buffer which does not know the color of any pixel until the end of its main loop.

There are five key advantages of ray tracing:

1. for preprocessed models, ray tracing is sub-linear in  $N$  [12], so for some sufficiently large value of  $N$  it will always be faster than a z-buffer which is linear in  $N$ ;
2. ray tracing can process curved surfaces such as splines in their native form [13];
3. ray tracing can naturally support volume data with partial transparency [14];
4. because a ray tracing program must perform a 3D line query, it can reuse this line query to easily generate shadows and reflections that also depend on a 3D line query (Fig. 3) [2];
5. the ray tracing algorithm is highly parallel, and has been demonstrated to have over 91% parallel efficiency on 512 processors [10].

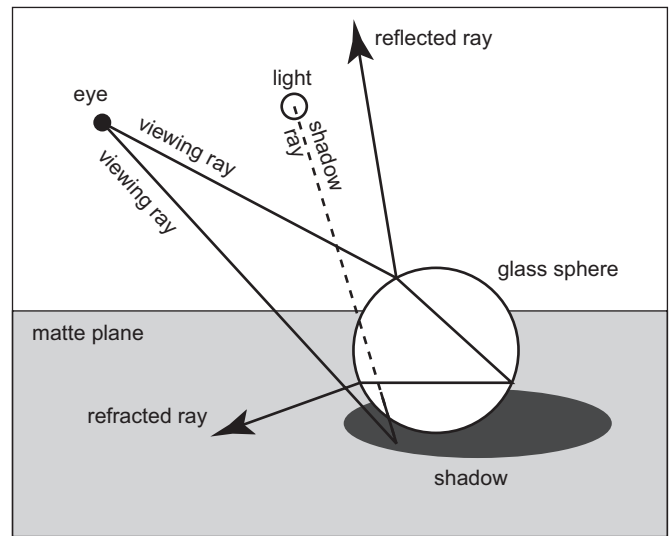

Fig. 3. Ray tracing can easily generate shadow rays, reflected rays, and refracted rays. These rays need not have a shared origin so they are difficult to duplicate for a z-buffer algorithm.

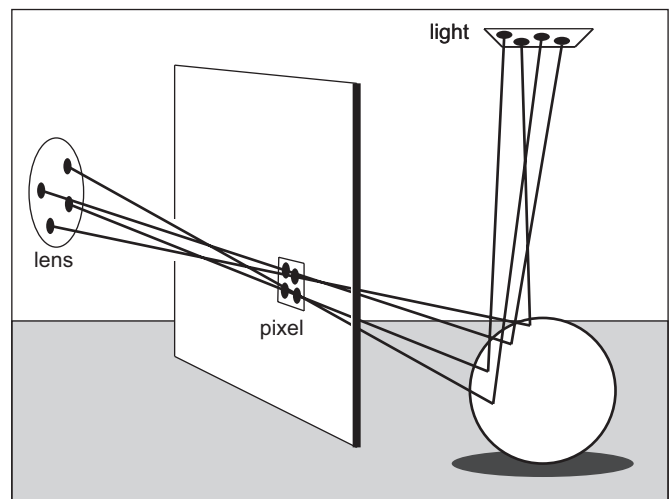

Fig. 4. In distribution ray tracing, multiple samples are taken per pixel and these are used both for antialiasing and other effects such as soft shadows as is shown here by sampling different points on an area light source.

While the z-buffer can be made to do specular reflections and shadows [15,16], the underlying techniques are neither general nor robust. However, the z-buffer algorithm does currently have two important advantages over ray tracing: although it is linear in  $N$ , it has a very low time constant so it can render scenes with moderate  $N$  very quickly; it has a mass-produced hardware implementation available that has lowered the time constant even further. Because the  $N$  for real applications is increasing exponentially for most applications, the time constant advantage is of decreasing importance. Further, the ubiquitous special purpose hardware exaggerates the time constant difference between ray tracing and the z-buffer approaches.

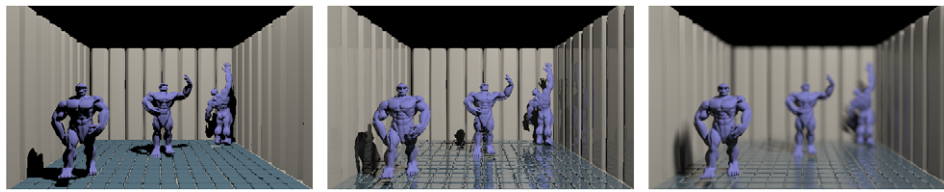

Fig. 5. Left: ray tracing with shadows only with 1 sample per pixel. Middle: Whitted-style ray tracing with 1 sample per pixel. Right: distribution ray tracing with 64 samples per pixel. We expect Whitted-style ray tracing to soon be on the desktop, and distribution ray tracing to later follow.

Ultimately, we expect *DRT* (Figs. 4 and 5) to end up on the desktop because of its higher image quality. However, because it requires tens of samples per pixel, it is intrinsically more expensive than traditional Whitted-style ray tracing.

Simulation and games demand interactivity and currently use z-buffer hardware almost exclusively. However, they spend a great deal of effort and programmer time creating complicated “hacks” to fake lighting effects and reduce  $N$  by model simplification and in the end they have imagery of inferior quality to that generated by ray tracing. Those industries would use ray tracing if it were fast enough.

### 3. Why we think ray tracing is coming

In this section we examine exactly what the gap is between current ray tracing performance and that needed for games, and speculate on how that gap will be closed. As a reference, we target a HDTV-type 1080p monitor (e.g., displays by game console) refreshed at 60 Hz, or “real time” frequency. This is about 2 million pixels per update.

Because visual quality is important, we must also consider “secondary” rays. These can be for shadows, reflections, or refractions. The individual viewing ray and secondary rays are sometimes called *ray segments* [17], and we will use that terminology. We note that for a general scene many ray segments per viewing ray are typically required. For example, a headlight model will have five segments for the simplest path through the assembly (one viewing ray, two refracted rays before the reflector, one reflected ray, and two refracted rays through inner and outer surfaces of the glass to leave the headlight). Other paths will have more. An architecture space will typically have dozens up to hundreds of lights, each generating a shadow ray segment.

The dominant visual artifact of interactive ray tracing programs is flickering caused by subpixel objects of different colors moving over the pixel center when the objects or eye moves [18]. This is best alleviated by sending multiple viewing rays per pixel and averaging the result, which not only alleviates flickering but also provides antialiasing. Current z-buffer systems use 4–9 samples per pixel on object edges to accomplish this. A high quality ray traced image must have at least 4 viewing rays per pixel.

Our own software implementation of Whitted ray tracing runs at approximately 1 million pixels per second

per core on complex scenes (hundreds of thousands of primitives) on a 2 GHz Opteron 870. For *DRT* with 64 samples per pixel we are about 100 times slower than that. The slowdown is more than a factor of 64 because in addition to using 64 times as many samples, the spread of rays resulting from sampling areas such as lights decreases coherence and adds some per-sample computation. So in software on one core with current CPU technology we are approximately a factor of 100 away from our 60 Hz 2 million pixel goal, and for *DRT* we are approximately a factor of 10,000 away. So we believe we need improvements of about 100 times over current one-core software systems for ray tracing to be fluid for games, and a further factor of 100 for *DRT* to become fluid.

For adequate, as opposed to ideal, performance, we could also assume 480p30 (300k pixels, 30 Hz). Further, we could use 16 samples per pixel for *DRT*. This puts us less a factor of 10 away for one core for Whitted-style ray tracing and less than a factor of 200 for *DRT* for one core. Given that eight-core CPUs are on the horizon, and dual CPU quad-core systems are available now, Whitted-style ray tracing in software should be fluid quite soon on the desktop with a 480p30 display. Because clock speeds and process sizes are unlikely to shrink much more [19], to gain a factor of 100 over current one-core systems, a change of architecture is probably needed.

A general rule of thumb in system design is that system generality and system performance are inversely correlated. That is, a system that is good in general is not excellent at anything in specific. This is exactly the insight that caused the GPU revolution in the 1980s [20–23]. A carefully crafted computational pipeline for transforming triangles and doing depth checks combined with an equally carefully crafted memory system to feed those pipelines combined to make our current generation of z-buffer GPUs possible. Current GPUs have up to 192 floating point units on a single GPU [24] and aggregate memory bandwidth of 15–30 Gbytes per second from their on-chip memories [25]. These combine to achieve graphics performance that is orders of magnitude higher than could be achieved by running the same algorithms on a general-purpose processor.

Virtually all of these performance gains of GPUs are due to architectural improvements. In fact, GPUs generally run with quite a bit slower clock than high-performance CPUs in the same process generation. A state of the art GPU might run at 300–450 MHz whereas a CPU might run at

close to 4 GHz. The architectural advantage comes mainly from custom floating point pipelines designed to execute the operations required for z-buffer graphics and from wide, fast, on-chip memory structures. Pipelines of this sort reduce the need to bring data in and out of a register file as is done on a general CPU. High-performance CPUs generally also use a large number of custom and dynamic circuits in their critical paths that are hand designed and hand tuned for speed. In general, custom circuits run between 3 to 8 times faster than even semi-custom cell-based ASICs [26], but these highly sensitive and difficult custom circuits are not typically required in GPUs, other than as part of their highly replicated floating point arithmetic units. This is encouraging because it means that if similar architectural improvements are possible for a ray tracing chip, extremely high-performance custom circuit techniques should not be necessary, other than for a few highly replicated arithmetic subsystems.

Fundamentally ray tracing, like GPUs, will require a special purpose pipeline of floating point arithmetic units tuned to a specific set of operations. There are three fundamental operations that must be supported: intersecting a ray with the spatial data structure that encapsulates the scene objects, intersecting the ray with the primitive objects contained in the selected data structure leaf nodes, and computing the illumination and color of the pixel based on the intersection with the primitive object and the collection of the contributions from the secondary ray segments. These operations are different enough from the GPU pipeline that it is unlikely that a GPU will ever support ray tracing in an effective way. However, it is certainly feasible to design suitable high-performance floating point units and connect them in ways suitable to the ray tracing algorithm. More promising are architectures such as Intel's Tera-scale prototype that use tens of simple cores with good floating point capabilities. Such chips would surely be better suited to ray tracing than current general-purpose CPUs, and would probably be sufficient for 1080p Whitted-style ray tracing. For DRT, a special purpose ray tracing chip may be needed. A prototype ASIC design indicates that this is probably a practical route even if improvements in process are slow from now on [27].

In summary, Whitted-style ray tracing at 480p30 is already fluid for complex models on eight-core systems. Improvements to hardware should allow a gradual migration to 1080p60 and later distribution ray tracer. The basic issues faced by users and programmers will not be influenced much by that migration. Because of ray tracing's high visual quality, it should have a market, and games programmers will need to understand ray tracing.

#### 4. Impact on computer graphics courses

Over the past two decades computer graphics courses [28–31] exhibit a pattern of curriculum refinement driven by the changes in graphics hardware. Although the

foundations in the field remain the same, the subset of these concepts covered and the context for which these concepts are presented have evolved significantly. For example, 20 years ago learning and practicing raster line drawing algorithms were relevant, while with current GPUs one can argue that it is more important to understand and practice the mathematics behind interactive camera control [31]. If we are correct that ray tracing will replace z-buffer then computer graphics courses will once again need to evolve.

Just as real time z-buffer hardware did not alter the *core* concepts in computer graphics, we do not expect real time ray tracing hardware to fundamentally impact the discipline. The topics covered in an introductory course will continue to be foundational concepts [32,33] such as transformation, hierarchical modeling, illumination models, camera modeling. However, as in the case of real time z-buffer, we expect the priority and context to evolve. We now list the biggest likely changes in emphasis.

*Illumination models:* Ray tracing integrates visibility and illumination computations. For example, shadows are computed as part of visible energy received from the light source, and reflection is computed as visible energy received from the mirror reflection direction. In this way, many common physical effects that are currently referred to as “special effects” (e.g., transparency, reflection, etc.) will evolve back into their natural illumination computations.

*Perspective transform and homogeneous coordinate:* Ray tracing simulates perspective naturally. For this reason, the mathematics model that simulates foreshortening and the associated homogeneous coordinate system will become less important. This will simplify the traditional transformation pipeline, where the last stage of the pipeline, projection transform, will not be needed anymore.

*Higher-order surfaces:* Ray tracing computes visibility by mathematically intersecting a line and a primitive. It is straightforward to ray trace mathematically defined higher-order surfaces such as trimmed NURBS. Without tessellation, higher-order primitives have much more compact representations while retaining all the original geometric integrity. For example, an implicit sphere can be represented by a handful of variables while the mathematic expression maintains quadratic continuity throughout the surface. The current heavier emphasis on object models based on tessellated triangle meshes will shift towards modeling based on surfaces' native representations.

*Volumetric effects:* Ray tracing supports volumetric data naturally. Volumetric effects like arial fog or more general participating media (e.g., smoke) can be modeled as semitransparent volumetric primitives with dedicated illumination models. The needs for special case shaders, *tricks*, and *hacks* for such effects will greatly diminished.

#### 5. Impact on computer gaming courses

The front end visualization of interactive computer games depends on computer graphics. Conversely, it is also

true that computer gaming is the single most important factor driving the development of computer graphics hardware. For these reasons, when discussing the impact of interactive ray tracing, we should also examine its effect on computer games. Future computer games will take advantage of the new functionality: the faster ray tracing hardware, and the drastically improved realism. As educators, our tasks are to analyze and understand how to evolve computer gaming courses/curricula accordingly.

The development of courses/curricula associated with computer gaming has lagged behind the industry quite significantly. While computer gaming has been around in different forms for many decades, the first classes dedicated to *games development* has become available only in the early 1990s [34]. During these early times there were very few computer gaming related classes. Most of the efforts in incorporating gaming into computer science classes/curricula had only recently demonstrated significant results (e.g., [35–41]). In addition, many of these efforts represented strategies to increase interest and enthusiasm for the discipline and to counter the drastic downturn in enrollments [42]. Although there are dedicated curriculum designed to educate next generation games developers (e.g., [35,43–46]), these programs are new; computer gaming as a discipline in computer science is a work-in-progress.

The following discussion is organized based on the framework described in Sung et al. [41], where we discuss the effects of interactive ray tracing in each of the: *game programming*, *game development*, and *game clients* categories.

*Game programming classes*: These are classes that study general technical issues related to programming computer games (e.g., Kuffner's CMU course [47]). For example, topics covered may include path planning algorithms, terrain representation, etc. The topics covered in these classes are general and typically can be applied to different domains. These classes concentrate on covering the games programming topic area in the IDGA [48] curriculum framework.

The following are games related programming issues associated with fast ray tracing.

- Ray tracing is capable of computing line/primitive intersection extraordinarily fast. The intersection computation is the foundation for supporting collision and selection. From the games programming perspective, the challenge would be to efficiently integrate this functionality into the core of games engine. In addition, the entire collision subsystem should be reevaluated. For example, with the ray tracing collision support, the merit of support collision primitives becomes questionable.
- Ray tracing naturally supports partial redraw where redraws only need to occur in regions that changed from previous frame. This means polygon/primitive count will not be the only factor affecting the bottom-line frame rate. In this case, the frame-to-frame coherency

may be even more important. From games programming perspective, it is important to understand and take advantage of temporal coherence.

*Game development classes*: These are classes that study how to design new games as an end product (e.g., [35,36,49]). Students in these classes must be concerned with all aspects of a real game production including entertainment value, visual quality, audio effects, etc. When evaluated against the IDGA curriculum framework we see that these classes cover all the major core topic areas. For these classes, the challenges are in game design to improve the aesthetic and the general game play experience based on the new functionality.

- As discussed, many existing *special* effects will become *common* and *natural* illumination effects with ray tracing. Not being special means there will be no special restrictions associated with the effects (e.g., no restriction on mirror must be planar). However it is also true that the computations of these effects will not be free or cheap. For example, although any and every object in a scene can be reflective, it is always faster to compute the frame with no reflections. In games development classes, students must learn to balance the new found flexibility, against the associated cost to achieve the specific aesthetic needs of their games.
- As discussed, the ray tracing hardware supports efficient collision detection, and the ray tracing paradigm supports partial redraw. These two characteristics suggest that as long as we limit the changes in consecutive frames, we can design and interact with scenes of high complexity. For example, walking into a room full of objects with detailed geometry with the ability to interact (e.g., pickup and open) with any object.

*Game client classes*: These are non-game related CS classes that creatively integrate games into their existing curriculum. Typically, games are used as programming assignments (e.g., [47,50–55]) or to teach abstract concepts (e.g., [39,41,52,56–58]), or as an example application area to teach the concepts involved in an entire topic area (e.g., [59–61]). These are *traditional* CS classes that exist independent from game programming. These classes are actually *clients* of game development where they *use* game development as a vehicle to deliver specific abstract concepts. After these classes, students are expected to understand the abstract concepts, and not the details of game development. These classes are *applications* of computer gaming, we expect the impact on classes in this category to be indirect and minimal.

*Discussion*: Our outline of changes to courses above is by no means exhaustive. Our areas of expertise are in computer graphics and computer architecture. Based on our knowledge, we predict interactive ray tracing will become more prominent in the near future. Because of our background, and because computer graphics is a better

established field, we have some understanding on the impact of this upcoming change with respect to computer graphics. We believe ray tracing will also significantly impact computer gaming and computer gaming related classes. In this last section, we presented our speculations, but we are not as confident in these ideas as games classes are much less well established than graphics classes.

## Acknowledgments

This work is supported in part by the National Science Foundation Grants DUE-0442420, NSF-0541009, and NSF 03-06151; and a grant from the Microsoft Research Gaming RFP award number 15871. All opinions, findings, conclusions, and recommendations in this work are those of the authors and do not necessarily reflect the views of the National Science Foundation or Microsoft.

## References

- [1] Catmull E. A subdivision algorithm for computer display of curved surfaces. PhD thesis, University of Utah; 1974.
- [2] Whitted T. An improved illumination model for shaded display. *Communications of the ACM* 1980;23(6):343–9.
- [3] Glassner A, editor. *An introduction to ray tracing*. London: Academic Press; 1989.
- [4] Shirley P, Morley RK. *Realistic ray tracing*. Natick, MA: A.K. Peters; 2003.
- [5] Boulos S, Edwards D, Laceywell JD, Kniss J, Kautz J, Shirley P, et al. Packet-based whitted and distribution ray tracing. Technical Report UUCS-06-013, School of Computing, University of Utah; 2006.
- [6] Bittner J, Wimmer M, Piringer H, Purgathofer W. Coherent hierarchical culling: hardware occlusion queries made useful. *Computer Graphics Forum* 2004;23(3):615–24.
- [7] Wand M, Fischer M, Peter I, auf der Heide FM, Strasser W. The randomized z-buffer algorithm: interactive rendering of highly complex scenes. In: *Proceedings of SIGGRAPH*; 2001. p. 361–70.
- [8] Luebke D, Watson B, Cohen JD, Reddy M, Varshney A. *Level of detail for 3D graphics*. New York: Elsevier Science Inc.; 2002.
- [9] Bishop G, Fuchs H, McMillan L, Zagier EJS. Frameless rendering: double buffering considered harmful. In: *Proceedings of SIGGRAPH*; 1994. p. 175–6.
- [10] Parker S, Martin W, Sloan P-PJ, Shirley P, Smits B, Hansen C. Interactive ray tracing. In: *Symposium on interactive 3D graphics*; 1999. p. 119–26.
- [11] Woolley C, Luebke D, Watson B, Dayal A. Interruptible rendering. In: *ACM symposium on interactive 3D graphics*; 2003. p. 143–51.
- [12] Cleary J, Wyvill B, Birtwistle G, Vatti R. A parallel ray tracing computer. In: *Proceedings of the association of Simula users conference*; 1983. p. 77–80.
- [13] Martin W, Cohen E, Fish R, Shirley PS. Practical ray tracing of trimmed nurbs surfaces. *Journal of Graphics Tools* 2000;5(1):27–52.
- [14] Upson C, Keeler M. VBUFFER: visible volume rendering. In: *Proceedings of SIGGRAPH*; 1988. p. 59–64.
- [15] Stamminger M, Drettakis G. Perspective shadow maps. In: *Proceedings of SIGGRAPH*; 2002. p. 557–62.
- [16] Wyman C. An approximate image-space approach for interactive refraction. In: *Proceedings of SIGGRAPH*; 2005.
- [17] Hurley J. Ray tracing goes mainstream. *Intel Technology Journal* 2005;9(2):99–108.
- [18] Martin W, Shirley P, Parker S, Thompson W, Reinhard E. Temporally coherent interactive ray tracing. *Journal of Graphics Tools* 2002;7(2):41–8.
- [19] 2004. International technology roadmap for semiconductors. ([www.itrs.net/Common/2004Update/2004Update.htm](http://www.itrs.net/Common/2004Update/2004Update.htm)).
- [20] Clark JH. The geometry engine: a vlsi geometry system for graphics. In: *SIGGRAPH '82: proceedings of the 9th annual conference on computer graphics and interactive techniques*. New York, NY, USA: ACM Press; 1982. p. 127–33.
- [21] Poulton J, Fuchs H, Austin JD, Eyles JG, Heineche J, Hsieh C, et al. PIXEL-PLANES: building a VLSI based raster graphics system. In: *Chapel Hill conference on VLSI*; 1985.
- [22] Fuchs H, Goldfeather J, Hultquist JP, Spach S, Austin JD, Frederick P, et al. Fast spheres, shadows, textures, transparencies, and image enhancements in pixel-planes. In: *SIGGRAPH '85: proceedings of the 12th annual conference on computer graphics and interactive techniques*. New York, NY, USA: ACM Press; 1985. p. 111–20.
- [23] Deering M, Winner S, Schediwy B, Duffy C, Hunt N. The triangle processor and normal vector shader: a vlsi system for high performance graphics. In: *SIGGRAPH '88: proceedings of the 15th annual conference on computer graphics and interactive techniques*. New York, NY, USA: ACM Press; 1988. p. 21–30.
- [24] ATI technologies inc. ([www.ati.com](http://www.ati.com)).
- [25] nVidia Corporation. ([www.nvidia.com](http://www.nvidia.com)).
- [26] Chinnery D, Keutzer K. *Closing the gap between ASIC & custom*. Dordrecht: Kluwer Academic Publishers Group; 2002.
- [27] Woop S, Brunvand E, Slusallek P. Estimating performance of a ray-tracing ASIC design. In: *Proceedings of IEEE symposium on interactive ray tracing*, p. 7–14.
- [28] Cunningham S, Brown JR, Burton RP, Ohlson M. Varieties of computer graphics courses in computer science. In: *Proceedings of SIGCSE*; 1988. p. 313.
- [29] Grissom S, Kubitz B, Bresenham J, Owen GS, Schweitzer D. Approaches to teaching computer graphics (abstract). In: *Proceedings of SIGCSE*; 1995. p. 382–3.
- [30] Hitchner L, Cunningham S, Grissom S, Wolfe R. Computer graphics: the introductory course grows up. In: *Proceedings of SIGCSE*; 1999. p. 341–2.
- [31] Angel E, Cunningham S, Shirley P, Sung K. Teaching computer graphics without raster-level algorithms. In: *Proceedings of SIGCSE*; 2006. p. 266–7.
- [32] Cunningham S. Powers of 10: the case for changing the first course in computer graphics. In: *Proceedings of the ACM SIGCSE technical symposium on computer science education (March)*; 2000. p. 293–6.
- [33] Wolfe R. Bringing the introductory computer graphics course into the 21st century. *Computers and Graphics* 2000;24(1):151–5.
- [34] Parberry I, Kazemzadeh MB, Roden T. The art and science of game programming. In: *Proceedings of SIGCSE*; 2006. p. 510–4.
- [35] Coleman R, Krembs M, Labouseur A, Weir J. Game design & programming concentration within the computer science curriculum. In: *Proceedings of SIGCSE*; 2005. p. 545–50.
- [36] Parberry I, Roden T, Kazemzadeh MB. Experience with an industry-driven capstone course on game programming: extended abstract. In: *Proceedings of SIGCSE*; 2005. p. 91–5.
- [37] Maxim B. Game design and implementation 1 and 2. Microsoft Academic Alliance Repository Newsgroup, Object ID: 6227, 2006 (<http://www.msdnaacr.net/curriculum/pfv.aspx?ID=6227>).
- [38] DXFramework. Dxfamework: a pedagogical computer game engine library. University of Michigan; 2006 (<http://dxframework.org/>).
- [39] MUPPET. Multi-user programming pedagogy for enhancing traditional study. Rochester Institute of Technology; 2006 (<http://muppets.rit.edu/muppetsweb/people/index.php>).
- [40] Parberry I. Sage: a simple academic game engine. University of North Texas; 2006 (<http://larc.csci.unt.edu/sage/>).
- [41] Sung K, Shirley P, Reed-Rosenberg R. Experiencing aspects of games programming in an introductory computer graphics class. In: *SIGCSE '07: Proceedings of the 38th SIGCSE technical symposium on Computer science education*. New York, NY, USA: ACM Press; 2007. p. 249–253.
- [42] Vegso J. Interest in cs as major drops among incoming freshmen. *Computing Research News* 2005;17(3).



- [43] Zyda M. Guest editor's introduction: educating the next generation of game developers. *Computer* 2006;39(6):30–4.
- [44] Murray J, Bogost I, Mateas M, Nitsche M. Game design education: integrating computation and culture. *Computer* 2006;39(6):43–51.
- [45] Fullerton T. Play-centric games education. *Computer* 2006;39(6):36–42.
- [46] Argent L, Depper B, Fajardo R, Gjertson S, Leutenegger ST, Lopez MA, et al. Building a game development program. *Computer* 2006;39(6):52–60.
- [47] Sweedyk E, deLaet M, Slattery MC, Kuffner J. Computer games and cs education: why and how. In: *Proceedings of SIGCSE; 2005*. p. 256–7.
- [48] IDGA. IGDA curriculum framework report version 2.3 beta, February. International Game Developer's Association, 2003 (<http://www.igda.org/academia>).
- [49] Jones RM. Design and implementation of computer games: a capstone course for undergraduate computer science education. In: *Proceedings of SIGCSE; 2000*. p. 260–4.
- [50] Adams JC. Chance-it: an object-oriented capstone project for cs-1. In: *SIGCSE '98: proceedings of the twenty-ninth SIGCSE technical symposium on computer science education*. New York, NY, USA: ACM Press; 1998. p. 10–4.
- [51] Faltin N. Designing courseware on algorithms for active learning with virtual board games. In: *ITiCSE '99: proceedings of the 4th annual SIGCSE/SIGCUE ITiCSE conference on innovation and technology in computer science education*. New York, NY, USA: ACM Press; 1999. p. 135–8.
- [52] Giguette R. Pre-games: games designed to introduce cs1 and cs2 programming assignments. In: *SIGCSE '03: proceedings of the 34th SIGCSE technical symposium on computer science education*. New York, NY, USA: ACM Press; 2003. p. 288–92.
- [53] Sung K, Shirley P. Returning adult students for algorithm analysis. *The Journal of Computing Sciences in Colleges* 20(2). *Proceedings of the sixth annual CCSC-NW conference*, 2004. p. 62–72.
- [54] Bayliss JD, Strout S. Games as a “flavor” of cs1. In: *SIGCSE '06: proceedings of the 37th SIGCSE technical symposium on computer science education*. New York, NY, USA: ACM Press; 2006. p. 500–4.
- [55] Lewis MC, Massingill B. Graphical game development in cs2: a flexible infrastructure for a semester long project. In: *SIGCSE '06: proceedings of the 37th SIGCSE technical symposium on computer science education*. New York, NY, USA: ACM Press; 2006. p. 505–9.
- [56] Becker K. Teaching with games: the minesweeper and asteroids experience. *Journal of Computing Sciences in Small Colleges* 2001;17(2):23–33.
- [57] Hansen S. The game of set: an ideal example for introducing polymorphism and design patterns. In: *SIGCSE '04: proceedings of the 35th SIGCSE technical symposium on computer science education*. New York, NY, USA: ACM Press; 2004. p. 110–4.
- [58] Dann W, Cooper S, Pausch R. *Learning to program with alice*. Upper Saddle River, NJ: Prentice-Hall; 2006.
- [59] da Silva FSC. Software engineering for computer games. University of Sao Paulo (USP/SP), Microsoft Academic Alliance Repository Newsgroup, Object ID: 6211, 2006 (<http://www.msdnaacr.net/curriculum/pfv.aspx?ID=6211>).
- [60] da Silva FSC. Artificial intelligence for computer games. University of Sao Paulo (USP/SP), Microsoft Academic Alliance Repository Newsgroup, Object ID: 6210, 2006 (<http://www.msdnaacr.net/curriculum/pfv.aspx?ID=6210>).
- [61] Chen W-K, Cheng YC. Teaching object-oriented programming laboratory with computer game programming. *IEEE Transactions on Education* 2007;50(3):197–203.