

Technology Adoption and Trade Policies

Koji Shimomura
Kobe University

Kar-yiu Wong
University of Washington

July 1, 2001

Abstract

We examine in a dynamic model how a firm determines the optimal level of innovation, and how a firm chooses between innovation and imitation. This paper considers a local firm, which is competing with a foreign, more productive, firm in terms of quantity, and at the same time, the local firm is able to spend the optimal amount of resources on innovation, with the purpose of closing the technology gap with the foreign firm. At the time of innovation, the firm has the option of spending less (or no) resources on innovation, if it decides to simply learn from (imitate) the foreign firm. Whether a firm chooses to imitate or to innovate depends on, among other things, how fast and how much it can imitate and also the cost of innovation. A full consideration of the decision of the local firm is allowed, as how a change in technology may affect the outputs of the firms, the market demand, and its profit will be analyzed carefully.

1 Introduction

International rivalry between firms in different countries has long been an important issue for trade theorists, business decision makers, and government policy planners. Rivalry can take many forms, including competition in terms of output production and technology. Traditionally, the trade theory pays more attention to the competition between foreign firms in terms of output production,¹ but much less to technology.

Technological progress is an important topic for economists. In the current growth literature, technology progress is treated as part of the model to be analyzed, and innovation and imitation are two of the most important channels through which a firm improves its technological level and competitiveness in the world market. Innovation is a deliberate action of a firm: It spends resources in a process through which the factors of production can be made more productive, or through which a new way of grouping factors of production can be found to make the production more cost effective, or through which a new product (or product with a different quality) can be found. In the economics theory, it is assumed that a firm spends resources on improving its technology in order to maximize an objective function (such as profit). Imitation is a less purposeful action. The firm tries to learn from other firms that have similar (in type) but more advanced technology. Learning, or imitating, is usually a much less costly process. In general, because firms involved have similar type of technology, they also compete in terms of output.

Most of the papers in the literature analyze either innovation and imitation separately. For example, in the past, Solow (1956) and Chipman (1970) regard innovation as an exogenous process. More recently, the work of Grossman and Helpman (1991), Rivera-Batiz and Romer (1991), and many others endogenize the innovation decision making. All these papers, however, do not allow the firms to imitate although their work does consider competition between the firms involved and other firms in terms of output, and the choice between innovation and imitation by the same firm is not considered. On the other hand, papers that considered imitation usually focus on imitation only, without the possibility that firms imitate have the option of innovation.

The consideration of either innovation or imitation, but not both, ignores the fact that many firms do imitate and innovate, although not necessarily

¹See, for example, Wong (1995, Chapter 12) for a recent survey of some of the issues.

at the same time. Even firms in developing countries have the option of innovate, and in various periods of time and for some industries, firms do spend significant resources on innovation, with the purpose of raising their technology levels.

To illustrate the choice between innovation and imitation, we can consider the case of Japan. Since the fifties, Japan gradually had been converting many low-tech industries to high-tech industries. At that time, many of the firms found that they were competing with American firms that had superior technologies. However, many Japanese firms quickly closed the gaps between their technology levels and those of the American firms. A common strategy for many firms was to first learn the American technology (imitation), and then to spend more and more resources on improve their own technology (innovation). As a result, many succeeded in not only catching up with the American technology but also surpassing the latter.

The Japanese model has been proved to be successful in raising their technology competitiveness, at least for many industries. Many developing countries, especially those in Asia, are following similar paths of technology catching up and surpassing, although different countries have made different achievements.²

In view of the development experience of these countries, we examine in a dynamic model how a firm determines the optimal level of innovation, and how a firm chooses between innovation and imitation. This paper considers a local firm, which is competing with a foreign, more productive, firm in terms of quantity, and at the same time, the local firm is able to spend the optimal amount of resources on innovation, with the purpose of closing the technology gap with the foreign firm. At the time of innovation, the firm has the option of spending less (or no) resources on innovation, if it decides to simply learn from (imitate) the foreign firm. Whether a firm chooses to imitate or to innovate depends on, among other things, how fast and how much it can imitate and also the cost of innovation. A full consideration of the decision of the local firm is allowed, as how a change in technology may affect the outputs of the firms, the market demand, and its profit will

²Hong Kong provides another example. For a long time, pirated, illegal softwares had been available in the local economy (imitation). The government banned the production and sale of these softwares, but recently the restrictions on piracy had been tightened. Starting from April 1, 2001, it became a crime to use pirated softwares. This came at a time when more and more local firms are developing new softwares (innovation) and are asking for intellectual property rights protection from the government.

be analyzed carefully. This paper can shed light on how firms in developing countries are competing with advanced firms in developed countries.

Section 2 of this explains the rivalry between two firms, one in each of the two countries. At any point of time, both firm take their technologies as given and compete in the rest of the world. Section 3 considers a dynamic model in which the local firm chooses the optimal resources on innovation, trying to catch up with the foreign firm. To simplify our analysis, the technology of the foreign firm is kept as constant. In this section, the special case of innovation only is considered. This assumption allows us to analyze more carefully the conditions under which the local firm will choose to surpass the technology of the foreign firm. Section 4 introduces imitation, and compares the major features of imitation and innovation. It also analyzes the choice of the local firm between imitation and innovation. We show the existence of an interesting case, in which the local firm first imitates, then turns to innovation, and then imitates again. In another case, the local firm may choose to imitate only, without spending any resources on innovation. In section 5, we examine how the local government may use an export tax to induce the local firm to innovate more in order to improve its technology even further in the long run. The last section concludes.

2 Rivalry between Two Firms

Consider two countries labeled home and foreign. In each of these two countries, there is a firm producing a homogeneous product. Call the firm in the home country firm 1 (or the home firm) and that in the foreign country firm 2 (or the foreign firm). At any point of time t , the technology of firm i is described by a marginal cost $c_i(t) > 0$ and a fixed cost $F_i > 0$, $i = 1, 2$. The fixed cost of each firm is constant over time and is independent of the output level. Concerning the marginal costs, the following simplifying assumptions are made:

1. The home firm has the option of imitation and/or innovation while the foreign firm does not. This means that $c_1(t)$ could drop over time while $c_2(t)$ is constant over time. From now on foreign marginal cost is simply represented by c_2 .
2. The foreign firm initially (when $t = 0$) has an advanced technology, i.e., a lower marginal cost, $c_1(0) > c_2$.

That the technology of the firm is assumed to be fixed is to simplify the analysis, but we will talk about the implications of this assumption later. As the home firm lowers $c_1(t)$ over time through imitation or innovation, the gap between $c_1(t)$ and c_2 is getting smaller and smaller; we say that the home firm *catches up*. If the home firm chooses to innovate, it is possible that there exists a finite time t' so that for $t > t'$, $c_1(t) < c_2$. If this happens, we say that the home firm *surpasses*.³ In order to simplify our notation, we drop the time subindex if no confusion arises; for example, $c_1(t)$ is simply written as c_1 .

There is demand for the product in the rest of the world but not in the home and foreign countries, meaning that the outputs of the two firms are exported. Let the demand be denoted by $p = a - bQ$, where Q is the market demand and p the market price. For simplicity, the time indices for p and Q are suppressed. Both parameters a and b are positive and constant over time, and a is large enough to support these two firms. Assuming no production of the product in the rest of the world, equilibrium of the market is described by:

$$Q = q_1 + q_2, \quad (1)$$

where q_i is the output of firm i , $i = 1, 2$. We now examine the production decision of the firms at any point of time, t . At any given point of time, the marginal costs of the firms are constant. The profit of firm i , $i = 1, 2$, is given by

$$\pi_i = p(Q)q_i - (c_i q_i + F_i). \quad (2)$$

Assuming Cournot competition and an interior solution, the first-order condition for firm i is

$$a - 2bq_i - bq_j - c_i = 0, \quad (3)$$

where $i \neq j$, and $i, j = 1, 2$. Condition (3) for each firm represents its best response to the output of its rival. The firms' best response functions are then combined to give the Nash equilibrium, from which we can determine the profit of each firm:

$$\pi_i(c_i; c_j) \equiv \frac{1}{9b}[(a + c_j) - 2c_i]^2 - F_i. \quad (4)$$

As mentioned above, a is assumed to be sufficiently large so that each firm gets a non-negative profit.

³We can have the special case in which t' is at infinity so that $c_1(t) > c_2$ for all finite times.

3 The Process of Innovation

We now examine how technology of the home firm may be improved over time.⁴ In this section, we examine innovation. The choice between innovation and imitation for the home firm will be analyzed later.

3.1 The Problem of the Home Firm

Suppose that the home firm is able to reduce its marginal cost at a rate of \dot{c}_1 after paying an expenditure on R & D equal to $g(-\dot{c}_1/c_1)$. The cost function $g(x)$, which is defined over the interval $[0, \bar{x}]$, where $\bar{x} > 0$, satisfies the following properties:

1. $g(0) = 0$ and $g(x) > 0$ for all $x \in (0, \bar{x}]$;
2. $g'(x) > 0$ and $g''(x) > 0$ for all $x \in (0, \bar{x})$;
3. $\lim_{x \rightarrow 0} g'(x) = \beta > 0$; $\lim_{x \rightarrow \bar{x}} g'(x) = +\infty$.

A possible $g(x)$ function is illustrated in Figure 1. We define x over an interval, implying that the marginal cost decreasing rate is bounded from above. This assumption is made for simplifying the mathematical analysis, and seems to be a reasonable one, since it may be too costly for the home firm to reduce its marginal cost at a very high rate.

We consider the following game. At each point of time, the decision of the firms can be conceptually divided into two stages. In the first stage, the home firm chooses the rate at which its marginal cost is reduced (which can be zero), taking the marginal cost of the foreign firm as given. In the second stage, both firms compete in a Cournot fashion, with the marginal costs given.

The problem of the home firm is to choose a path of reducing its marginal cost, knowing that once its marginal cost has been chosen, the firms compete in terms of output. Because the second stage at any point of time is the same as the case described in the previous section, the following analysis focuses on the first stage, with both firms fully aware of the effects of changes in home firm's marginal cost on their outputs and profits.

⁴Recall that for simplicity the technology of the foreign firm is assumed to be fixed over time.

The problem of the home firm is:

$$\max_x \int_0^\infty [\pi_1(c_1; c_2) - g(x)]e^{-rt} dt \quad (5)$$

subject to

$$\begin{aligned} \dot{c}_1 &= -xc_1 \\ 0 &\leq x \leq \bar{x}, \end{aligned}$$

where $c_1(0) > 0$ and $c_2 > 0$ are given and $r > 0$ is the discount rate.

3.2 Existence of an Optimal Solution

We now examine whether an optimal solution to the problem in (5) exists. Because the convexity of the profit function implies that the Hamiltonian associated with the present dynamic problem is not concave, the Mangasarian or Arrow sufficiency conditions are not applicable. To achieve our objective, we introduce an existence theorem implied by Seierstad and Sydaeter (1987, Theorem 15, p. 237).

Theorem 1: *Consider the following dynamic optimization problem*

$$\max \int_0^\infty u(x(t), c(t))e^{-rt} dt, \quad r > 0$$

subject to

$$\begin{aligned} \dot{c}(t) &= f(x(t), c(t)) \\ c(0) &= c_0, \text{ given} \end{aligned}$$

and

$$x(t) \in U, \text{ a fixed subset of } R^1.$$

Suppose:

1. $u(x, c)$ and $f(x, c)$ are continuous.
2. U is closed and bounded.

3. There exist piecewise continuous functions $\phi_i(t) \geq 0$, $i = 0, 1$, with $\int_0^\infty \phi_i(t)dt < \infty$ such that

$$|u(x(t), c(t))e^{-rt}| \leq \phi_0(t) \quad (6)$$

$$|f(x(t), c(t))| \leq \phi_1(t) \quad (7)$$

for all admissible pairs $(x(t), c(t))$ and all $t \geq 0$.

4. There exist piecewise continuous, non-negative functions $d(t)$ and $e(t)$ such that

$$\|(u(x, c)e^{-rt}, f(x, c))\| \leq d(t) \|c\| + e(t), \text{ for all } (x, c, t). \quad (8)$$

5. The set

$$N(c, U, t) \equiv \{(u(x, c)e^{-rt} + z, f(x, c)) : x \in U, z \leq 0\}$$

is convex for all (c, t) .

Then the existence of an admissible pair implies the existence of an optimal pair $(c^*(t), x^*(t))_{t=0}^{t=\infty}$.

Theorem 1 is used to give the following existence theorem, the proof of which is given in the appendix:

Proposition 1 *For any given initial condition, there exists an optimal solution to the above problem.*

3.3 Analysis of An Optimal Solution

Once the existence of an optimal solution is assured, we can try to analyze it by making use of the standard necessary conditions for optimality. Let us denote the Hamiltonian for the home firm's problem in (5) by

$$H \equiv \pi_1(c_1; c_2) - g(x) - \lambda x c_1.$$

To simplify our notation, in what follows we simply write $\pi_1(c_1; c_2)$ as $\pi(c_1)$. According to the standard necessity theorem⁵, for any optimal solution to the

⁵See Seierstad and Sydsaeter (1987, Theorem 12, p. 234).

problem in (5), there is a continuous and piecewise differentiable continuous function of time $\lambda(t)$ which satisfies the following conditions:⁶

$$\frac{\partial H}{\partial x} = -g'(x) - \lambda c_1 \leq 0 \quad (9)$$

$$[g'(x) + \lambda c_1]x = 0, \quad x \geq 0$$

$$\dot{\lambda} = r\lambda - \pi'(c_1) + \lambda x. \quad (10)$$

Let us define $y \equiv -\lambda c_1$ and denote the inverse function of $g'(x)$ by $\psi(y)$, i.e., $x = \psi(-\lambda c_1) = \psi(y)$. Condition (9) and the properties of $g(\cdot)$ imply that function $\psi(y)$ has the following properties:

$$\psi(y) = 0 \text{ for any } y \in [0, \beta] \quad (11)$$

$$\psi'(y) > 0 \text{ for any } y > \beta \quad (12)$$

$$\lim_{y \rightarrow \infty} \psi(y) = \bar{x}. \quad (13)$$

A possible function $x = \psi(-\lambda c_1)$ is depicted by the curve in Figure 2. Using this function, we see that an optimal solution for the home firm has to satisfy the following dynamic system of equations:

$$\dot{c}_1 = -c_1 \psi(-\lambda c_1) \quad (14)$$

$$\dot{\lambda} = r\lambda - \pi'(c_1) + \lambda \psi(-\lambda c_1). \quad (15)$$

The phase diagram corresponding to the dynamics equations (14) and (15) is illustrated in Figure 3. Let us explain this diagram and use it to examine the properties of the dynamic system. First, curve ABCDE represents the equation $\beta = -\lambda c_1 = y$. In the region on or above the curve, $y \leq \beta$. By condition (11), $\psi(-\lambda c_1) = 0$, and by (14), $\dot{c}_1 = 0$. Similarly, in the region below curve ABCDE, $\dot{c}_1 < 0$. Second, let us consider the condition $r\lambda - \pi'(c_1) = 0$. Making use of home firm's profit function (4), the condition reduces to

$$\lambda = \frac{4}{9br} [2c_1 - (a + c_2)]. \quad (16)$$

Recall that c_2 is given, condition (16) can be represented by the straight line FBDG in Figure 3. Let us focus on this line. By (15), $\dot{\lambda} = \lambda \psi(-\lambda c_1)$.

⁶Let I be an interval in R and $\lambda(t)$ be a function of time: $t \in I \rightarrow R$. $\lambda(t)$ is piecewise continuously differentiable if there is a piecewise continuous function $\phi(t) : I \rightarrow R$ such that for almost every $t \in I$, $\phi(t)$ is differentiable at t and $d\lambda(t)/dt = \phi(t)$.

Because on and above (below) ABCDE $-\lambda c_1 \leq (>) \beta$, condition (11) again implies that

$$\dot{\lambda} = \begin{cases} = \\ < \\ = \end{cases} 0 \text{ on } \begin{cases} \text{FB (including point B)} \\ \text{BD (excluding points B and D)} \\ \text{DG (including point D)} \end{cases} .$$

Similarly, on curved segment BCD (excluding points B and D), $\dot{\lambda} = r\lambda - \pi'(c_1) > 0$ because $\psi(\beta) = 0$. It follows that by continuity there is a locus between points B and D along which $\dot{\lambda} = 0$. We depict this by locus BHD (excluding points B and D), which is in between line BD and curve BCD.

Making use of the above results, we can depict possible trajectories for the dynamic system by the curves with arrows in Figure 3. The above results are summarized as follows.

Lemma 1. For the dynamic system given by (14) and (15), $\dot{c}_1 = 0$ on and above curve ABCDE while $\dot{\lambda} = 0$ on FBHGD. A stationary state characterized by no movement in c_1 and λ can be depicted by line segments FB and DG.

Despite the existence of multiple stationary states, for any given initial condition $c_1(0)$ the optimal solution may uniquely exist. This is what we now turn to. Figure 3 shows the initial value $c_1(0)$. When the home firm has chosen the initial value $\lambda(0)$, the initial point is represented by a point on the vertical line RS. In terms of the possible location of the initial point, line RS can be divided into four regions:

1. line segment RC, including point C. In this region, $c_1(t)$ does not change, i.e., $c_1(t) = c_1(0)$ for all $t \geq 0$. The co-state variable $\lambda(t)$, however, is rising. Thus the adjustment path is a vertical line, rising upward.
2. segment CN, excluding point N. In this region, $c_1(t)$ will be decreasing while $\lambda(t)$ will initially be rising (if the initial point is in between points C and H) or falling (if the initial point is below point H). If, for example, the initial point is at point M, then the trajectory will be something like schedule MM'M''M'''.

3. point N. With an initial point at N, the trajectory will be along path NB.
4. line segment NS, excluding point N. The trajectory will be along a path such as LY, which will sooner or later go below point B.

It turns out that point B, which is represented by (c_1^*, λ^*) , is an important point in the present analysis, where:

$$\lambda^* = \frac{4}{9br} [2c_1^* - (a + c_2)] \quad (17)$$

$$-\lambda^* c_1^* = \beta \equiv g'(0). \quad (18)$$

To determine the optimal path, let us introduce a necessary condition as stated in the following theorem, which is implied directly by Seierstad and Sydaeter (1987, Theorem 16, pp. 244–5):

Theorem 2: *Consider the dynamic optimization problem stated in Theorem 1 and assume that $(x^*(t), c^*(t))$ is optimal with*

$$\int_0^\infty |u(x^*(t), c^*(t))e^{-rt}| dt < \infty$$

and

$$\int_0^\infty |f(x^*(t), c^*(t))| dt < \infty \quad (19)$$

and that there exist nonnegative numbers A, B, C, a, b, k with $a > 0$ and $b > k$ such that for all $t \geq 0$ and all c

$$\frac{\partial}{\partial c} u(x^*(t), c)e^{-rt} \leq Ae^{-at} \quad (20)$$

$$\frac{\partial}{\partial x} u(x^*(t), c)e^{-rt} \leq Be^{-bt} \quad (21)$$

$$\frac{\partial}{\partial c} f(x^*(t), c) \leq Ce^{kt} \quad (22)$$

$$\frac{\partial}{\partial x} f(x^*(t), c) \leq k. \quad (23)$$

Then, there exists a continuous and twice-continuously differentiable $\lambda_j^*(t)$ which satisfies the following transversality condition

$$\lim_{t \rightarrow \infty} \lambda^*(t)e^{-rt} = 0. \quad (24)$$

as well as the standard necessary conditions for optimality.

From Theorem 2 and condition (24), it is clear that for sufficiently small r (> 0), the transversality condition requires that $\lambda(t)$ remains finite as time approaches infinity. This theorem thus precludes regions RC, CN (excluding point N), and NS (excluding point N) for the optimal initial value $\lambda(0)$. In other words, the home firm should choose the value of $\lambda(0)$ as given by point N.

Since the existence of an optimal trajectory is guaranteed, the trajectory NB that converges to the stationary state must be the unique optimal solution. We now arrive at the following proposition.

Proposition 2 *Suppose that $(\pi(c_j(\infty)) - g_j(\bar{x}) \leq \pi(0) - g_j(\bar{x}) < 0$. (i) For any $c_1(0) > c_1^*$, there is a sufficiently small $r(> 0)$ such that KB describes the unique optimal solution. (ii) for any $c_1(0) \in (0, c_1^*)$, $c_1(t) = c_1(0)$, i.e., $x(t) = 0$ for any $t > 0$, is the optimal solution.*

The above analysis implies a simple rule for the home firm: If its initial marginal cost is equal to or less than c_1^* , then it should stay unchanged, with the co-state variable chosen to be the value corresponding to a point on line segment FB. If the initial value of its marginal cost is greater than c_1^* , then the value of the co-state variable should be chosen to be a point on trajectory KB.

3.4 Comparative Statics

We now examine how the stationary-state value of the marginal cost is affected by some of the parameters. Here we focus on the stationary state represented by point B, which is described by equations (17) and (18). Substituting condition (18) into (17), we have the quadratic equation

$$2(c_1^*)^2 - (a + c_2)c_1^* + \frac{9br\beta}{4} = 0, \quad (25)$$

which can be solved for c_1^* :

$$c_1^* = \frac{1}{4} \left[(a + c_2) - \sqrt{(a + c_2)^2 - 18br\beta} \right]. \quad (26)$$

Note that a is assumed to be big enough so that the (26) represents a real root.⁷ It is clear from (26) that $\partial c_1^*/\partial b > 0$ and $\partial c_1^*/\partial r > 0$. Partially

⁷Note that the other root represents point D in Figure 4.

differentiating (26) with respect to $(a + c_2)$, we have

$$\frac{\partial}{\partial(a + c_2)} c_1^* = \frac{1}{4} \left[1 - \frac{(a + c_2)}{\sqrt{(a + c_2)^2 - 18br\beta}} \right] < 0. \quad (27)$$

The above results are summarized in the following proposition:

Proposition 3 *The stationary-state marginal cost of home firm c_1^* depends on the parameters in the following ways.*

1. *(demand parameters): $\partial c_1^*/\partial a < 0$, $\partial c_1^*/\partial b > 0$; [A lower or a steeper demand curve gives a higher stationary-state marginal cost.]*
2. *(discount rate): $\partial c_1^*/\partial r > 0$; [A higher future evaluation (= a smaller r) gives a lower c_1^* .]*
3. *(the rival's marginal cost): $\partial c_1^*/\partial c_2 < 0$. [A less efficient rival firm (= a higher c_2) will induce the home firm to choose a lower stationary-state marginal cost.]*

3.5 Catching Up and Surpassing

Condition (27) and the previous proposition imply a negative relation between the two firms' marginal costs in the steady state. Such a relation can be illustrated by the negatively-sloped schedule MN in Figure 4. For example, if the initial point representing the technologies (marginal costs) of the firms is above schedule MN, say, point A, then over time, the home firm will reduce its marginal cost until a point on the schedule vertically below point A is reached, i.e., point E. Note that point E is the steady-state point corresponding to the marginal cost of the foreign firm. In this particular, the home firm catches up.

One interesting issue we want to investigate is whether the home firm chooses to have a technology higher than that of the foreign firm, or whether the home firm surpasses. Figure 4 provides us the answer, which depends on the location of the initial point. The diagram shows three possible cases with initial points, A, B, and D, all representing the same initial marginal cost of the home firm, c_1^0 , but different foreign marginal cost. If the initial point is A, meaning that the initial foreign marginal cost is c_2^E , then as the home firm innovates, point A shifts down until it reaches point E, at which

the home marginal cost is c_1^E . In the diagram, point E is above the 45°-line, meaning that $c_1^E > c_2^E$, i.e., although the home firm catches up, it does not surpass. Point D represents another case: The home firm eventually gets a technology higher than that of the foreign one at the stationary state point G: $c_1^G < c_2^G$, i.e., the home firm first catches up and eventually it surpasses the foreign firm. Point B, which is directly above the intersecting point between the 45°-line and schedule MN. When the final point F is reached, both firms have the same marginal cost, \bar{c} : The firms become identical in terms of marginal cost.⁸

The value of \bar{c} can be determined from (25). Setting $c_1^* = c_2 = \bar{c}$, the condition reduces to

$$\bar{c}^2 - a\bar{c} + 9br\beta/4 = 0,$$

which gives⁹

$$\bar{c} = \frac{a - \sqrt{a^2 - 9br\beta}}{2}.$$

The above results are summarized in the following proposition:

Proposition 4 *Suppose that the foreign technology is superior to the home technology, and if innovation is the only way the home firm can use to improve its technology. (a) If $c_2 < \bar{c} < c_1^* < c_1(0)$, then the home firm will catch up but no surpassing will take place. (b) If $\bar{c} < c_2 < c_1(0)$, then the home firm will catch up and will eventually surpass the foreign firm. (c) If $\bar{c} = c_2 < c_1(0)$, then the home firm will catch up in terms of technology until the two firms have the same marginal cost. (d) If $c_2 < c_1^* < \bar{c} < c_1(0)$, then no catch up or surpass will take place.*

In terms of Figure 4, the four cases in the above proposition can be depicted by points A, B, C, and a point in between points E and H, respectively.

4 Imitation Versus Innovation

So far, we have analyzed innovation as the only channel through which the home firm can improve its technology. We now introduce the second channel:

⁸The firms may still have different fixed costs. They will choose to produce the same output, but their profits may be different.

⁹The other root represents point D in Figure 3. Recall that a is assumed to be sufficiently large so that \bar{c} is a real number.

imitation.

4.1 The Mechanics of Imitation

Imitation here means a direct and costless technology spillover from the foreign firm to the home firm.¹⁰ Specifically, we assume that the home firm learns from the foreign firm with an advanced technology, without any costs, so that its marginal cost decreases over time according to the following condition:

$$\dot{c}_1 = -h(c_1 - c_2)c_1, \quad (28)$$

where function $h(w)$ has the following properties:

1. $h(w) = h'(w) = h''(w) = 0$ for $w \leq 0$;
2. $h(w) > 0$, $h'(w) > 0$ and $h''(w) > 0$ for $w > 0$.

Property (1) means that no imitation will take place if the foreign technology is not superior to the home technology, and property (2) implies that the rate of imitation is higher the greater the gap between the foreign and home technologies. Imitation is different from innovation in that it represents a costless flow of technology from the foreign firm to the home firm. The result of imitation is that the home firm's marginal cost decreases at a rate given by (28). The approach we adopt is that if the home firm spends nothing on R&D, its technology improves according to (28), but if it spends on R&D, then its marginal cost will drop as given by function $g(x)$. Since innovation is costly but imitation is costless, the firm will never spend resources on innovation that will cause a rate of reduction of its marginal cost lower than that given by (28).

4.2 The Imitation/Innovation Problem

Since to the home firm imitation is an external process, there is no optimization for the firm. So the choice between imitation and innovation boils down to whether the home firm would spend resources on innovation and

¹⁰That imitation is assumed to be costless is to simplify our analysis. Alternatively, we can assume that imitation requires some costs, but as long as they are lower than those for innovation, our analysis remains qualitatively the same.

how much. As a result, the dynamic optimization problem of the home firm can be formulated as

$$\max_{x, \delta} \int_0^{\infty} [\pi(c) - \delta g(x)] e^{-rt} dt \quad (29)$$

subject to

$$\begin{aligned} \dot{c}_1 &= -\delta x c_1 - (1 - \delta) h(c_1 - c_2) c_1 \\ 0 &\leq x \leq \bar{x} \\ \delta &\in \{0, 1\} \\ c_1(0), c_2 &> 0 \text{ are given.} \end{aligned}$$

In (29), δ is a control variable that has two values, 0 and 1. Choosing δ to be 1 means that the home firm innovates, and if $\delta = 0$, the firm imitates. This problem looks similar to the previous one; the difference is that in the previous problem, imitation is not an option so that the home firm in general has an incentive to spend resources on innovation. In the present problem, since imitation exists and is costless (or much less costly), under certain conditions the home firm may choose to spend nothing on innovation.

To solve the problem in (29), we try to make use of the analysis and results in the previous section. First, we slightly modify the above problem so that δ is chosen from the closed interval $[0, 1]$, not the set $\{0, 1\}$. With this modification, we first check for the existence of an optimal solution, i.e., checking the five conditions in Theorem 1. It is easy to see that conditions 1-4 in Theorem 1 are satisfied. To check for condition 5, note that the set $N(c, U, t)$ now becomes

$$N(c, U, t) = \{(X, Y) : \delta \in [0, 1], x \in [0, \bar{x}], z \leq 0\},$$

where

$$\begin{aligned} X &= \left[\frac{1}{9b} \{2c - (a + c_2)\}^2 - F_1 - \delta g(x) \right] e^{-rt} + z \\ Y &= -\delta x c - (1 - \delta) h(c - c_2) c. \end{aligned}$$

Lemma 2: The set $N(c, U, t)$ is convex.

Proof. See the appendix. ■

Making use of Lemma 2, we immediately have the following theorem:

Theorem 5 *There is an optimal solution to the modified optimization problem.*

To find out the optimal solution, let us define the Hamiltonian for the present problem as

$$H = \pi(c_1) - \delta g(x) + \lambda[-\delta x c_1 - (1 - \delta)h(c_1 - c_2)c_1]. \quad (30)$$

4.3 Pure Imitation

In this section let us look at the special case when only imitation exists, i.e., the firm chooses $\delta = 0$. The dynamic system becomes

$$\dot{c}_1 = -h(c_1 - c_2)c_1 \quad (31)$$

$$\dot{\lambda} = r\lambda - \pi'(c_1) + \lambda\{h(c_1 - c_2) + c_1 h'(c_1 - c_2)\}. \quad (32)$$

Note that since this is purely an external process, there is no optimization for the home firm. Making use of the properties of function $h(\cdot)$, we can derive the phase diagram of the system in Figure 5 as follows.

First, we note that imitation exists only when $c_1 > c_2$, i.e., c_1 is decreasing until it is equal to c_2 . Next, we draw line ABC that represents the equation $r\lambda - \pi'(c_1) = 0$. In the region below the line, $r\lambda - \pi'(c_1) < 0$, and since $\lambda < 0$, condition (32) implies that $\dot{\lambda} < 0$. In the region above line ABC, $r\lambda - \pi'(c_1) > 0$, This implies that $\dot{\lambda} > 0$ at least when λ is numerically small enough. Thus we can find combinations of c_1 and λ that gives $\dot{\lambda} = 0$. In the diagram, these combinations are illustrated by schedule BDC. Note that points B and C are on this schedule. To see why, note that at point B, $c_1 = c_2$, implying that $h(c_1 - c_2) = h'(c_1 - c_2) = 0$. At point C, $\lambda = \dot{\lambda} = 0$. We further note that there exists a saddle path, shown as KB in the diagram, so that an initial point on it will move along it toward point B. Based on this analysis, the phase diagram can be illustrated in Figure 5.

4.4 On Choosing between Innovation and Imitation

We now focus on the Hamiltonian (30). Since δ has to be chosen between the closed interval $[0, 1]$ to maximize the Hamiltonian, we can see that the firm will choose $\delta = 1$ if

$$-g(\psi(-\lambda c_1)) + (-\lambda c_1)\psi(-\lambda c_1) > (-\lambda c_1)h(c_1 - c_2). \quad (33)$$

In other words, if condition (33) holds, the firm will choose to innovate over imitation. Alternatively, the firm will choose $\delta = 0$ and to imitate if

$$-g(\psi(-\lambda c_1)) + (-\lambda c_1)\psi(-\lambda c_1) < (-\lambda c_1)h(c_1 - c_2). \quad (34)$$

The home firm is indifferent to innovation and imitation if (c_1, λ) satisfies

$$-g(\psi(-\lambda c_1)) + (-\lambda c_1)\psi(-\lambda c_1) = (-\lambda c_1)h(c_1 - c_2). \quad (35)$$

Condition (35) is an interesting one because it divides the (c_1, λ) space into region(s) in which the firm chooses $\delta = 1$ and region(s) in which the firm prefers $\delta = 0$. So let us analyze this condition more carefully. First, from the definition of function $h(\cdot)$, when $c_1 = c_2$,

$$h(c_1 - c_2) = 0. \quad (36)$$

Also, from the definitions of $g(\cdot)$ and $\psi(\cdot)$, for any λ that satisfies $-\lambda c_1 \leq \beta$,

$$-g(\psi(-\lambda c_1)) + (-\lambda c_1)\psi(-\lambda c_1) = 0. \quad (37)$$

Consider Figure 6, which shows the value of c_2 . Points along the vertical line through c_2 satisfy condition (36). We construct curve ABCDE, which satisfies $-\lambda c_1 = \beta$. This means that in the region above curve ABCDE, which represents $-\lambda c_1 \leq \beta$, condition (37) is satisfied. Combining these results, we say that vertical segment NC is part of the curve that represents (35). We now derive the rest of the curve for (35), which is shown as curve LMC in Figure 6.

Let us differentiate condition (35) to yield the slope of LMC:

$$\left. \frac{d\lambda}{dc_1} \right|_{\text{LMC}} = -\frac{(g'/c_1)^2}{g} [c_1 h'(c_1 - c_2) + h(c_1 - c_2) - \psi(-\lambda c_1)]. \quad (38)$$

If we evaluate the slope in a region close to point C, i.e., c_1 is slightly greater than c_2 , (38) reduces to

$$\left. \frac{d\lambda}{dc_1} \right|_{\text{LMC at C}} = \frac{(g'/c_1)^2 \psi(-\lambda c_1)}{g} > 0.$$

When c_1 is sufficiently greater than c_2 so that $c_1 h'(c_1 - c_2) + h(c_1 - c_2) > \psi(-\lambda c_1)$, then the slope of schedule LMC is negative. Thus condition (35)

is represented by the vertical segment CN plus a curve like LMC, which has a zero slope somewhere at point M. Making use of the above results, we now know that if the firm is at a point below (or above) LMC, it will choose innovation (or imitation).

We now derive the stationary state of the system. Like what we did earlier, we construct schedule ABCDE, which represents $-\lambda c_1 = \beta$. As explained in the previous section, in the region above this schedule, $\dot{c}_1 = 0$ if technology progress can come only from innovation, and in the region below this curve, c_1 drops if the firm chooses to innovate. We also construct line FBDG, which represents $r\lambda = \pi'(c_1)$. The co-state variable λ is stationary in line segments FB and DG, but is falling in line segment BD. The coordinates of point B are c_1^* and λ^* .

The analysis in the previous section can also be used here to show that if innovation is chosen, there exists a saddle path which represents the optimal solution. If, however, imitation is preferred, it exists so long as $c_1 > c_2$. In Figure 6, such an optimal path is represented by schedule KB. This means that c_1 and λ will adjust until point B (c_1^*, λ^*) is reached.

In drawing Figure 6, two possible cases have to be distinguished. In case (a), $c_2 > \bar{c}$, where as shown earlier \bar{c} is the value of the marginal cost of the foreign firm to which the home firm will respond with innovation until its marginal cost is the same as the foreign one. When $c_2 > \bar{c}$ in the present case, the home firm, if innovation is the only option for technology improvement, will choose to have a stationary-state marginal cost lower than \bar{c} . In other words, $c_1^* < c_2$. This is the case shown in Figure 6.

Before turning to the second case, let us analyze this case further. We explained earlier that if condition (33) is satisfied, or if the point in Figure 6 is below schedule LMC, innovation will be chosen, but if condition (34) holds, the firm will choose imitation. Furthermore, imitation exists only if $c_1 > c_2$. Using the analysis in the previous and present sections, we can find an optimal path for the home firm, which is shown as KQB in Figure 6. This path cuts schedule LMC at point Q, with KQ (QB) above (below) schedule LMC, and will reach point B. We can use the approach introduced in the previous section to argue that trajectories above or below KQB are suboptimal.

Thus the home firm will choose to imitate along the segment KQ, but will choose to innovate along the segment QB. If the initial marginal cost of the home firm is sufficiently close to that of the foreign firm, then the initial point is below LMC. This means that only innovation occurs.

In the present case, the stationary-state value of c_1 is less than c_2 . This means that the home firm catches up and eventually surpasses the foreign firm.

Proposition 6 *Suppose that $c_2 > \bar{c}$, which implies $c_1^* < c_2$. The optimal trajectory is depicted like KQB in Figure 6. If the initial cost $c_1(0)$ is sufficiently great, there is an early stage during which the home firm imitates the advanced foreign firm. When c_1 is lowered sufficiently, the home firm stops imitation and starts resource-using innovative activity. Its marginal cost c_1 monotonously converges to c_1^* .*

Remark 1 *It is clear that in Proposition 4 δ is chosen as either 0 or 1. Thus, Proposition 4 can be straightforwardly carried over to the case of the original dynamic optimization (36) in which δ is in an interval $(0, 1)$, not in a two-element set $\{0, 1\}$.*

We now turn to an alternative case (b) with $c_1 < \bar{c}$. We analyzed in the previous section that if innovation is the only option for technology improvement, the home firm will choose to be less productive than the foreign firm. In the present case in which both innovation and imitation are available, an interesting question is whether the home firm will remain less productive in the stationary state.

The analysis is carried out in terms of the phase diagram Figure 7, which can be derived in a similar way. Schedule ACBDE represents $-\lambda c_1 = \beta$. Point C corresponds to the marginal cost of the foreign firm, c_2 , while point B is the intersection point with line FBDG, which stands for $r\lambda = \pi'(c_1)$. In Figure 6, point B is the stationary-state point, with both c_1 and λ remaining constant. In the present case, would point B be still the stationary-state point? The answer is no because at this point $c_1 > c_2$. Therefore imitation still exists until c_1 drops down to be the same as c_2 .

As a result, the optimal path will look something like schedule KNPR in Figure 7. It is downward sloping, as both c_1 and λ are declining. The important thing is that the path will end at point R, not point B. The reason is that R is a point on FB so that $\dot{\lambda} = 0$, and at R $c_1 = c_2$ so that imitation stops. Also, since $c_2 < \bar{c}$, meaning that innovation is no longer profitable. In other words, in the stationary state, both firms have the same marginal cost: the home firm catches up but does not surpass.

In the diagram, we can also construct schedule LMC. As analyzed before, a point below (above) the schedule means that the home firm finds innovation (imitation) a better option for technology improvement. Depending on the relative positions of the optimal path KNPR and LMC, two cases can be identified. In the case shown in the diagram KNPR cuts LMC at points N and P. Along segments KN and PR, the home firm imitates, while along segment QP the firm innovates.

An alternative case, which is not shown, is one in which the optimal path is entirely above LMC. This means that the home firm just imitates and will not spend resources on innovate.

Proposition 7 *Suppose that $c_2 < \bar{c}$, which implies $c_2 < c_1^*$. If c_2 is sufficiently close to \bar{c} , the converging trajectory crosses the innovation area at an intermediate stage like in Figure 7. It is possible that only imitation takes place during the whole period.*

From the analysis presented above, we can see that whether the local firm chooses to innovate or imitate depends on the market conditions and the initial conditions such as the marginal costs of the firms. Basically, we can distinguish between the following two cases:

1. $c_2 > \bar{c}$. In this case, the local firm will improve its technology until it is more productive than the foreign firm. In other words, the local firm surpasses the foreign firm in terms of technology. This is the case shown in Figure 6. The diagram shows that as long as the initial marginal cost of the local firm, $c_1(0)$, is sufficiently high, the firm will imitate first. This is because the large gap between the marginal costs makes imitation more cost effective. Over time imitation is not so effective, and eventually it comes to the point at which the firm is willing to spend resources on innovation. In other words, the local firm first imitate and then innovate.
2. $c_2 < \bar{c}$. In this case, the local firm will catch up but will not surpass the foreign firm. Figure 7 shows the case in which the local firm first imitates, then innovates, and finally imitates. Of course if the marginal cost of the local firm is not too much higher than the foreign firm's marginal cost, it is possible that the local firm first innovates and then imitates, or just imitates. One possibility not shown in Figure 7 but mentioned above is that the optimal path is entirely above curve LMC. In this case, the local firm will imitate only.

5 Innovation As A Constraint

The current literature assumes that a firm is given the option of either innovate or imitate, but not both. We now use the present model, which is more general as innovation and imitation are options for the home firm, to examine what the present literature may have missed.

Let us first consider the case in which $c_2 < \bar{c}$. Figure 8 shows such a case. With the marginal costs of the firms, $c_1(0)$ and c_2 , given, the initial point on the optimal path of innovation/imitation is shown as point K, which is below curve LMQC. As argued in the previous section, the optimal path of the local firm is KQR. As explained, the local firm will innovate along path KQ, and will imitate beyond point Q until point R is reached. At point R, which represents the stationary state, the local firm's marginal cost is the same as that of the foreign firm.

Consider an alternative path of the local firm: It innovates only, without the possibility of imitation. We want to examine the implications of taking away of option of imitation from the firm. The optimal path is the one shown in Figure 3, which is shown as path HB in Figure 8. We want to compare the innovation path HB with the innovation/imitation path KQR.

First, we note that if imitation is allowed, the local firm is able to eventually lower its marginal cost to that of the foreign firm, c_2 . This is point R. If, however, only innovation is allowed, the local firm will lower its marginal cost to a level higher than c_2 . This is because the foreign firm is very productive, and as shown Figure 4 shows, the local firm will not choose to surpass the foreign firm's technology. The stationary state point is B.

Second, we note that path HB and segment KQ are described by equations (14) and (15). Let point S be a point on path HB vertically above or below point Q. If point S is above (below) point Q, then point H has to be above (below) point K. Segment QR is described by equations (31) and (32).

Third, the position of point H relative to point K has an implication on the resources spent on innovation. Let us consider the case shown in Figure 8. Since point H is higher than point K, the corresponding value of $y \equiv -\lambda c_1$ is lower at H than at K, i.e., $y_H < y_K$. Because $x \equiv \psi(y)$ is an increasing function of y and $g(x)$ an increasing function of x , we have $x_H < x_K$ and $g(x_H) < g(x_K)$. In other words, in the case shown, the local firm spends less on innovation if innovation is the only means to improve technology. This case is further illustrated in Figure 9. Schedule HB shows how much the local firm spends, measured by $g(x)$, on innovation over time when innovation is

the only option for technology improvement. It is decreasing and approaches zero as time goes to infinity. If the local firm has the option of innovation and then imitation, it will innovate first, spending along KQ in the diagram. The latter curve is also declining over time. When point Q is reached, the firm switches to imitation, stopping all expenditure on innovation. After that, no resources are spent, as the firm chooses imitation.

The diagram shows the case in which point Q is below schedule HB. This means that if imitation is an option, the local firm will spend more on innovation first, trying to lower its marginal cost at a faster rate, knowing that beyond Q it has to spend nothing on imitation. However, it is possible that point Q is above schedule HB. In this case, when imitation is possible, the local firm spends more on innovation first and then less as compared with what it will do in the absence of the imitation option.¹¹

We now try to see how the cost of innovation may affect whether the local firm spends more or less without imitation. To do that, let us slightly modify the cost function of innovation: $\delta g(z)$, where, as compared with the previous function, $\delta > 0$ is a parameter and $z \equiv x/\delta$. We assume that the function $g(z)$ is the same as what was described earlier. As done before, $\psi(\cdot)$ is defined as the inverse function of $g'(z)$. The system of differential equations (14) and (15) are replaced by

$$\dot{c}_1 = -c_1 \delta \psi(-\lambda c_1) \quad (39)$$

$$\dot{\lambda} = r\lambda - \pi'(c_1) + \lambda \delta \psi(-\lambda c_1). \quad (40)$$

On the other hand, the system of differential equations that describes the imitation process is given by (31) and (32), and are repeated here:

$$\dot{c} = -ch(c - c_2) \quad (41)$$

$$\dot{\lambda} = r\lambda - \pi'(c) + \lambda[h(c - c_2) + ch'(c - c_2)]. \quad (42)$$

Note that while the differential equations (39) and (40) depend on the parameter δ , equations (41) and (42) do not. Moreover, the stationary state of both systems are also independent of δ ¹², and so is the (imitation) trajectory

¹¹The case in which point H is below point K in Figure 10 is not analyzed here, but cannot be examined along the same line.

¹²Note that the stationary state is derived from

$$\delta \psi(-\lambda c_1) = 0$$

RQ in Figure 8. Now let us check how the (innovation) trajectory HB is affected by the value of δ . The slope of the trajectory HB is

$$\begin{aligned} \left. \frac{d\lambda}{dc_1} \right|_{\text{HB}} &= \frac{r\lambda - \pi'(c_1) + \lambda\delta\psi(-\lambda c_1)}{-c_1\delta\psi(-\lambda c_1)} \\ &= \frac{\pi'(c_1) - r\lambda}{c_1\delta\psi(-\lambda c_1)} - \frac{\lambda}{c_1}. \end{aligned}$$

It is clear that the slope is getting steeper and steeper as δ is getting smaller and smaller. As we showed in footnote 11, the stationary state is independent of δ . It follows that for a sufficiently small δ , the two trajectories RQ and HB never cross each other, i.e., in Figure 8 point S is above point Q. Furthermore, if point S is above Q, and since the two trajectories HS and KQ come from the same system of differential equations, HS and KQ do not cross. Thus we can say that as δ is very small, trajectory HSB is entirely above trajectory KQR.

What does a small δ mean? Recall that the cost of innovation is $\delta g(z)$. When δ is small, z becomes large. Because $g(z)$ is bounded from above, $\delta g(z)$ approaches zero as δ approaches zero. This means that a small δ means that the cost of innovation is low. By the proposition, low innovation cost implies that trajectory HSB in Figure 8 is above trajectory KQR. In Figure 9, KQ is entirely above the corresponding segment of schedule HB. This means that if a local firm is given the option of innovation and imitation, and if the cost of innovation is sufficiently low, then the firm will first spend more resources on innovation, and then chooses nothing on technology progress beyond Q because it learns from the foreign firm free of charge.

We now have the following proposition:

Proposition 8 *If δ is sufficiently small, then (a) the cost of innovation is small; (b) the constrained innovation trajectory HSB in Figure 8 is always above the optimal trajectory KQR; and (c) the local firm will first choose to spend more on innovation, and then spends nothing on imitation, as compared with what it will do if imitation is ruled out.*

$$r\lambda - \pi'(c_1) = 0,$$

where, as long as $\delta > 0$, the first equation is equivalent to $-\lambda c_1 = \beta \equiv g'(0)$. Thus, the stationary state is independent of δ .

6 Welfare Effects of Trade Policies

Suppose that the home firm has achieved the stationary state (point B in Figure 3). Can the home government improve the home welfare by imposing some trade policies? Specifically, we would like to examine whether the home government which seeks to enhance the home welfare should impose an export tax or not.

Let us denote by τ_1 an ad valorem export tax imposed by the home government. The instantaneous home profit is

$$\begin{aligned}\pi_1 &= (a - bQ - \tau_1)q_1 - c_1q_1 - F_1 \\ &= (a - bQ) - (\tau_1 + c_1)q_1 - F_1.\end{aligned}\quad (43)$$

On the other hand, the profit function of the foreign firm is the same as before

$$\pi_2 = (a - bQ)q_2 - c_2q_1 - F_2. \quad (44)$$

Comparing (43) and (44), it is clear that an imposition of export tax means that the marginal cost of the home firm rises so that the home firm has to start R&D activity again. What we would like to check is whether this “forced” improvement in technology of the export firm can enhance the national welfare of the home country. Since we assume no demand and consumption in the home and foreign countries, the home welfare can be represented by

$$W \equiv \int_0^\infty [\pi_1 + \tau_1q_1]e^{-rt}dt. \quad (45)$$

What we are going to check is the sign of

$$\left. \frac{\partial W}{\partial \tau} \right|_{\tau=0}. \quad (46)$$

To achieve our purpose, we have to write (43) in terms of c_1 . Considering that the first-order conditions (3) derived earlier can be rewritten as

$$2bq_1 + bq_2 = a - (\tau + c_1) \quad (47)$$

$$bq_1 + 2bq_2 = a - c_2, \quad (48)$$

we have

$$q_1 = \frac{1}{3b}[a - 2(\tau + c_1) + c_2] \quad (49)$$

$$q_2 = \frac{1}{3b}[a - 2c_2 + \tau + c_1]. \quad (50)$$

Substituting (49) and (50) into (43), we get

$$\pi_1 = \frac{1}{9b}[(a + c_2) - 2(c_1 + \tau)]^2. \quad (51)$$

Therefore, the partial differentiation of $\pi_1 + \tau q_1$ with respect to τ at $\tau = 0$ yields

$$\left. \frac{\partial[\pi_1 + \tau q_1]}{\partial \tau} \right|_{\tau=0} = -\frac{q_1}{3}[1 + 4c_{1\tau}], \quad (52)$$

where $c_{1\tau} \equiv \partial c_1 / \partial \tau$. Therefore,

$$\left. \frac{\partial W}{\partial \tau} \right|_{\tau=0} = -\int_0^\infty \frac{q_1}{3}[1 + 4c_{1\tau}]e^{-rt} dt. \quad (53)$$

To check the sign of (53), we need to know the time profile of $c_{1\tau}(t)$ along the optimal trajectory KB in Figure 3. Now, let us recall that the optimal trajectory has to satisfy the system of differential equations

$$\dot{c}_1 = -c_1 \psi(-\lambda c_1) \quad (54)$$

$$\dot{\lambda} = r\lambda - \frac{4}{9b}[2c_1 - (a - \tau + c_2)] + \lambda \psi(-\lambda c_1). \quad (55)$$

Partially differentiating both sides of (54) and (55) with respect to τ , we have the system of variational equations

$$\dot{c}_{1\tau} = c_1^* \lambda \psi' c_{1\tau} + (c_1^*)^2 \psi' \lambda_\tau \quad (56)$$

$$\dot{\lambda}_\tau = -\left[\frac{8}{9b} + \lambda^2 \psi'\right] c_{1\tau} + [r - c_1^* \lambda \psi'] \lambda_\tau - \frac{4}{9b}. \quad (57)$$

Note that since $c_1(0)$ is given, $c_{1\tau}(0) = 0$. If initially the stationary state B in Figure 3 is achieved, the coefficients are all time-invariant. Therefore, the system of variational equations is a system of linear differential equations with constant coefficients.

Let us denote by $\bar{c}_{1\tau}$ and $\bar{\lambda}_\tau$ the solution to

$$0 = c \lambda \psi' c_{1\tau} + (c_1^*)^2 \psi' \lambda_\tau \quad (58)$$

$$0 = -\left[\frac{8}{9b} + \lambda^2 \psi'\right] c_{1\tau} + [r - (c_1^*) \lambda \psi'] \lambda_\tau - \frac{4}{9b}. \quad (59)$$

Solving for $c_{1\tau}$ and λ_τ , we get

$$\bar{c}_{1\tau} = -\frac{4/9b}{[8/9b - \lambda\tau/c_1^*]} = -\frac{1}{a + c_2} < 0 \quad (60)$$

$$\bar{\lambda}_\tau = \frac{\lambda}{c_1^*(a + c_2)} < 0. \quad (61)$$

Note that we use (54) = (55) = 0 in order to derive the second equality in (60). Since the Jacobian matrix corresponding to the system is the same as the one corresponding to (56) and (57) evaluated at the stationary state, $\bar{c}_{1\tau}$ and $\bar{\lambda}_\tau$ are nothing but the long-run effects of imposing an export tax on c_1 and λ .

Now let us obtain the solution to the system of differential equations (56) and (57). Since the two Jacobian matrices are the same, the characteristic roots must be also the same, i.e., one positive and one negative roots, say $y_1 > 0$ and $y_2 < 0$. Following the standard method to solve linear differential equations, we have the solution.

$$c_{1\tau} = A_1 e^{y_1 t} + A_2 e^{y_2 t} + \bar{c}_{1\tau} \quad (62)$$

$$\lambda_\tau = \frac{y_1 - (c_1^*)\lambda\psi'}{(c_1^*)^2\psi'} A_1 e^{y_1 t} + \frac{(y_2 - c_1^*\lambda\psi')}{(c_1^*)^2\psi'} A_2 e^{y_2 t} + \bar{\lambda}_\tau. \quad (63)$$

Considering the initial condition $c_{1\tau}(0) = 0$ and that $c_{1\tau}$ and λ_τ converge to $\bar{c}_{1\tau}$ and $\bar{\lambda}_\tau$, respectively, we have

$$\begin{aligned} A_1 &= 0 \\ A_2 &= -\bar{c}_{1\tau} = \frac{1}{a + c_2}. \end{aligned}$$

Therefore, we derive

$$c_{1\tau}(t) = -\bar{c}_{1\tau}(1 - e^{y_2 t}) = \frac{-(1 - e^{y_2 t})}{a + c_2}. \quad (64)$$

Since $y_2 < 0$, for any $t > 0$, $-(1 - e^{y_2 t})/(a + c_2) < 0$: An imposition of an export tax reduces the marginal cost of the home firm not only in the long run but also in the intermediate stage.

Now let us obtain the welfare effect of the export tax. Substituting (64) into (53), we see that

$$\left. \frac{\partial W}{\partial \tau} \right|_{\tau=0} = -\int_0^\infty \frac{q_1}{3} [1 + 4c_{1\tau}] e^{-rt} dt$$

$$\begin{aligned}
&= -\frac{q_1}{3} \int_0^\infty \left[1 + \frac{4e^{y_2 t}}{a+c_2} - \frac{4}{a+c_2} \right] e^{-rt} dt \\
&= -\frac{q_1}{3} \int_0^\infty \left[\frac{a+c_2-4}{a+c_2} + \frac{4e^{y_2 t}}{a+c_2} \right] e^{-rt} dt \\
&= -\frac{q_1}{3} \left[\frac{a+c_2-4}{(a+c_2)r} + \frac{4}{(a+c_2)(r-y_2)} \right] \\
&= -\frac{q_1}{3} \frac{(a+c_2-4)}{(a+c_2)r(r-y_2)} \left[\frac{(a+c_2)r}{a+c_2-4} - y_2 \right]. \tag{65}
\end{aligned}$$

First, it is clear from the third equality that (65) is negative if $a+c_2-4 > 0$. Let us assume that $a+c_2-4 < 0$. The characteristic equation corresponding to the Jacobian matrix of (56) and (57) is

$$\begin{aligned}
f(y) &\equiv \begin{vmatrix} y - c_1^* \lambda \psi' & -(c_1^*)^2 \psi' \\ \frac{8}{9b} + \lambda^2 \psi' & y - (r - c_1^* \lambda \psi') \end{vmatrix} \\
&= y^2 - ry + c_1^* \psi' \left[r\lambda + \frac{8c_1^*}{9b} \right] \\
&= y^2 - ry - \frac{4c_1^* \psi'}{9b} \sqrt{(a+c_2)^2 - 18br\beta} = 0 \tag{66}
\end{aligned}$$

where use is made of (56) = 0 and (33) in the text. Thus,

$$f(y_2) = 0$$

Considering that $f(y) > 0$ for any $y < y_2$ and that $r(a+c_2)/(a+c_2-4) < 0$, we see that if

$$f\left(\frac{r(a+c_2)}{a+c_2-4}\right) > 0, \tag{67}$$

then $r(a+c_2)/(a+c_2-4) - y_2 < 0$, which implies that (65) is negative.

Let us check under what conditions (67) hold. Note that

$$f\left(\frac{r(a+c_2)}{a+c_2-4}\right) = \frac{4r^2(a+c_2)}{(a+c_2-4)^2} - \frac{4c_1^* \psi'}{9b} \sqrt{(a+c_2)^2 - 18br\beta}. \tag{68}$$

Since c_1^* does not depend on ψ' , we can say that (60) holds for a sufficiently small ψ' .

Proposition 9 *If $4 - (a + c_2) < 0$, an imposition of the export tax on the home product reduces the home welfare. Even if $4 - (a + c_2) > 0$, we have the negative welfare effect for a sufficiently small ψ' .*

Remark: Suppose that in the stationary state the marginal cost of the home firm is still higher than the foreign marginal cost. Then it is attempting for the home government to take a measure to reduce the home marginal cost. For example, suppose that the home government imposes an export tax. The home firm faces an increase in its effective marginal cost [= (the home marginal cost) +(an ad valorem export tax rate)]. As a result, the home firm starts R&D activity. As (57) shows, the home marginal cost declines. However, the above proposition asserts that under certain conditions the R&D activity induced by the trade policy has a negative effect on the home national welfare.

Finally, let us check the effects of the home export tax on π_1 and π_2 . Note that π_2 represents in our model the foreign national welfare. Using (49), we have

$$\begin{aligned}\pi_1 &= \frac{1}{9b}[(a + c_2) - 2(c_1 + \tau)]^2 \\ \pi_2 &= \frac{1}{9b}[(a - 2c_2) + (a + c_1)]^2.\end{aligned}$$

Thus,

$$\begin{aligned}\left. \frac{\partial \pi_1}{\partial \tau} \right|_{\tau=0} &= -\frac{4}{3}q_1(1 + c_{1\tau}) \\ \left. \frac{\partial \pi_2}{\partial \tau} \right|_{\tau=0} &= \frac{2}{3}q_2(1 + c_{1\tau}).\end{aligned}$$

By making a parallel argument to the analysis of the impacts on national welfare, we can obtain the following result.

Proposition 10 *Suppose that ψ' is very small or that $a + c_2 - 1 > 0$. Then,*

$$\begin{aligned}\int_0^\infty \left. \frac{\partial \pi_1}{\partial \tau} \right|_{\tau=0} dt &= -\frac{4q_1}{3} \frac{(a + c_2 - 1)}{(a + c_2)r(r - y_2)} \left[\frac{(a + c_2)r}{a + c_2 - 1} - y_2 \right] < 0 \\ \int_0^\infty \left. \frac{\partial \pi_2}{\partial \tau} \right|_{\tau=0} dt &= \frac{2}{3}q_2 \frac{(a + c_2 - 1)}{(a + c_2)r(r - y_2)} \left[\frac{(a + c_2)r}{a + c_2 - 1} - y_2 \right] > 0.\end{aligned}$$

Note that the second inequality means that the foreign national welfare rises as a result of the imposition of the home export tax.

7 Concluding Remarks

In this paper, we developed a dynamic model to analyze the optimal innovation and imitation of a local firm, which is competing with a firm in another country. The model is used to analyze how the technology of the home firm may be improved if the firm chooses (or is forced) to innovate or to imitate. One important feature of this paper is that it examines how the home firm chooses between innovation and imitation. Our analysis shows that under certain conditions, the home firm may choose to imitate first, then innovate, and then imitate. The firm chooses to do that because in some periods it is more cost effective to imitate while at some other times innovation is a better way of improving technology even though the option of learning from a foreign firm is available.

Endogenizing the choice between innovation and imitation, which is rarely done in the literature, is useful and can be used to explain why some economies choose to prohibit privacy at some stages of their development.

The present model is based on some simplifying assumptions. Some of these assumptions are common in the literature; for example, one firm in one market, no domestic consumption, Cournot competition, and so on. We did make some further assumptions; for example, a linear demand. The latter assumption allows us to derive the function forms and even an explicit solution.

One assumption that requires more explanation is that the technology of the foreign firm is kept constant over time. This assumption greatly simplifies the present analysis as we have one less variable to solve for. We now see what implications this assumption has. The most direct consequence is that we have ignored the interactions and competition between the firms in terms of technology, although they still compete in terms of output. Another implication is that in the long run the technology of the home firm is not less than that of the foreign firm. This is because the home firm is always able to imitate at no cost. So soon or later the home technology must rise up to at least the foreign technology level. Of course, if the home firm decides to innovate, it may surpass the foreign firm. These two possibilities, however,

are not consistent with some cases, as many firms in developing countries constantly lag behind the advanced firms in the North. To capture this fact, however, we can relax some of the assumptions in this paper. For example, we can assume that imitation also is costly and requires the spending of some resources. In this case, it is possible that imitation will stop before the marginal cost of the home firm drops down to be the same as that of the foreign firm. However, in this case, the distinction between innovation and imitation is no longer so clear. Moreover, assuming a costly imitation does not change our analysis much.

An alternative approach is to assume that the foreign firm's technology keeps on improving. In this case, it is possible that in a steady state there remains a constant gap between the two firms' technological levels even though both of them are rising over time. In this case, it is necessary to explain how the foreign firm's technology is improved. If the foreign technology improvement is assumed exogenous, the present analysis does not require too much changed.¹³ The more interesting case is the one in which the two firms compete both in technology and output.¹⁴

¹³See, for example, Krugman (1979).

¹⁴See, for example, Spencer and Brander (1983), for an analysis, but they do not consider the issues examined in the present paper.

Appendix

Proof of Proposition 1. We first check Theorem 1 of existence can be applied to our problem. Let us define $u(x, c)$ and $f(x, c)$ as

$$u(x, c) \equiv \frac{1}{9b}[2c - (a + c_2)]^2 - F_1 - g(x) \quad (\text{A1})$$

$$f(x, c) \equiv -xc. \quad (\text{A2})$$

First, it is clear that both $u(x, c)$ and $f(x, c)$ are continuous. Second, defining U as the closed interval $[0, \bar{x}]$, we see that U is bounded and closed. Third, let $\phi_0(t) \equiv [a + c_2]^2/9b + F_1 + g(\bar{x})$ and $\phi_1(t) \equiv \bar{x}c_0$. Then we can see that (6) and (7) are satisfied for all admissible pairs $(x(t), c(t))$ and all $t \geq 0$. Fourth, defining $\|(d, e)\| \equiv [d^2 + e^2]^{1/2}$, $d, e \in R^1$, we see that $\|(d, e)\| \leq |d| + |e|$. Therefore, it follows from (6) and (7) that for all (x, c, t)

$$\begin{aligned} \|(u(x, c)e^{-rt}, f(x, c))\| &\leq |u(x(t), c(t))e^{-rt}| + |f(x(t), c(t))| \\ &\leq \frac{1}{9b}[a + c_2]^2 + F_1 + g(\bar{x}) + \bar{x}c_0. \end{aligned}$$

Therefore (8) holds if $d(t)$ is an arbitrary piecewise continuous, non-negative function and

$$e(t) \equiv \frac{1}{9b}[a + c_2]^2 + F_1 + g(\bar{x}) + \bar{x}c_0.$$

Fifth, under the specification (A1) and (A2), we have

$$\begin{aligned} N(c, U, t) &= \left\{ \left(\left[\frac{1}{9b} \{2c - (a + c_2)\}^2 - F_1 - g(x) \right] e^{-rt} + z, -xc \right) \right. \\ &\quad \left. : x \in [0, \bar{x}], z \leq 0. \right\} \end{aligned}$$

For any given (c, t) , the set $N(c, U, t)$ can be depicted as the shaded area in Figure A1, which is clearly convex. Thus, all the five conditions are satisfied. Finally, the pair $(c(t), x(t)) \equiv (c_0, 0)_{t=0}^{\infty}$ is an admissible pair. ■

Proof of Lemma 2. Recall that the set

$$N(c, U, t) = \{(X, Y) : \delta \in [0, 1], x \in [0, \bar{x}], z \leq 0\},$$

is defined by

$$\begin{aligned} X &= \left[\frac{1}{9b} \{2c - (a + c_2)\}^2 - F_1 - \delta g(x) \right] e^{-rt} + z \\ Y &= -\delta xc - (1 - \delta)h(c - c_2)c. \end{aligned}$$

We now show that this set is convex. Graphically it is shown in Figure A2. Choose any two elements of the set, say (X_1, Y_1) and (X_2, Y_2) , where

$$X_i \equiv \left[\frac{1}{9b} \{2c - (a + c_2)\}^2 - F_1 - \delta_i g(x_i) \right] e^{-rt} + z_i \quad (\text{A3})$$

$$Y_i = -\delta_i x_i c - (1 - \delta_i)h(c - c_2)c, \quad (\text{A4})$$

$i = 1, 2$. Since $(X_i, Y_i) \in N(c, U, t)$, $\delta_i \in [0, 1]$, $x_i \in [0, \bar{x}]$, and $z_i \leq 0$ have to hold for $i = 1, 2$. Considering the definition of convex sets, it suffices to prove that for any $\phi \in [0, 1]$

$$(\phi X_1 + (1 - \phi)X_2, \phi Y_1 + (1 - \phi)Y_2) \in N(c, U, t) \quad (\text{A5})$$

For a given ϕ , let us define the following variables:

$$\begin{aligned} \tilde{\delta} &\equiv \phi \delta_1 + (1 - \phi) \delta_2 \\ \tilde{x} &\equiv \phi \delta_1 x_1 + (1 - \phi) \delta_2 x_2 \\ \tilde{g} &\equiv \phi \delta_1 g(x_1) + (1 - \phi) \delta_2 g(x_2) \\ \tilde{z} &\equiv \phi z_1 + (1 - \phi) z_2 \\ \tilde{X} &\equiv \phi X_1 + (1 - \phi) X_2 \\ \tilde{Y} &\equiv \phi Y_1 + (1 - \phi) Y_2. \end{aligned}$$

Substituting (A3) and (A4) into (A5),

$$\tilde{X} = B - \tilde{g} e^{-rt} + \tilde{z} \quad (\text{A6})$$

$$\tilde{Y} = -\tilde{x}c - [1 - \tilde{\delta}]h(c - c_2)c, \quad (\text{A7})$$

where $B \equiv [\{2c - (a + c_2)\}^2 - F_1]e^{-rt}/9b$. First, (A6) can be rewritten as

$$\begin{aligned} \tilde{X} &= B - \tilde{\delta} \frac{\tilde{g}}{\tilde{\delta}} e^{-rt} + \tilde{z} \\ &\leq B - \tilde{\delta} g\left(\frac{\tilde{x}}{\tilde{\delta}}\right) e^{-rt} + \tilde{z}. \end{aligned}$$

The inequality is implied by the assumption that the function $g(x)$ is strictly convex. It follows that there is a non-negative ϵ such that

$$\tilde{X} = B - \tilde{\delta}g\left(\frac{\tilde{x}}{\tilde{\delta}}\right)e^{-rt} + \tilde{z} - \epsilon \quad (\text{A6})$$

Second, (A7) can be rewritten as

$$\tilde{Y} = -\tilde{\delta}\frac{\tilde{x}}{\tilde{\delta}}c - [1 - \tilde{\delta}]h(c - c_2)c. \quad (\text{A7})$$

We now show that for any $\phi \in [0, 1]$ $(\phi X_1 + (1 - \phi)X_2, \phi Y_1 + (1 - \phi)Y_2) \in N(c, U, t)$. First, we note that if $\lambda, \delta_1, \delta_2 \in [0, 1]$, so is $\tilde{\delta}$. Second, since \tilde{x} is a convex combination of x_1 and x_2 , and because both belong to $[0, \tilde{x}]$, so does \tilde{x} . Third, since $\{\phi z_1 + (1 - \phi)z_2\} \leq 0$ and $\epsilon \geq 0$, so $\tilde{z} - \epsilon < 0$. Therefore $(\tilde{X}, \tilde{Y}) \in N(c, U, t)$. ■

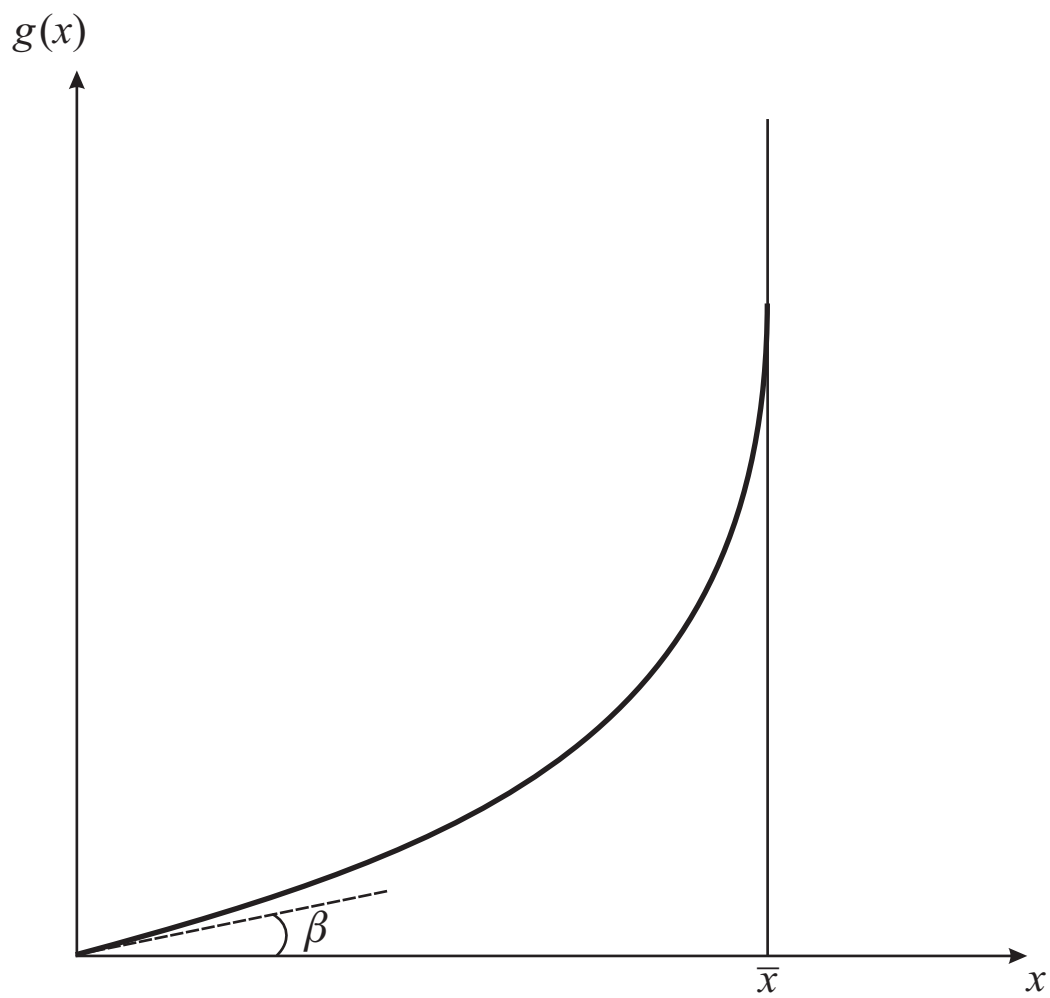

Figure 1

The Graph of $g(x)$

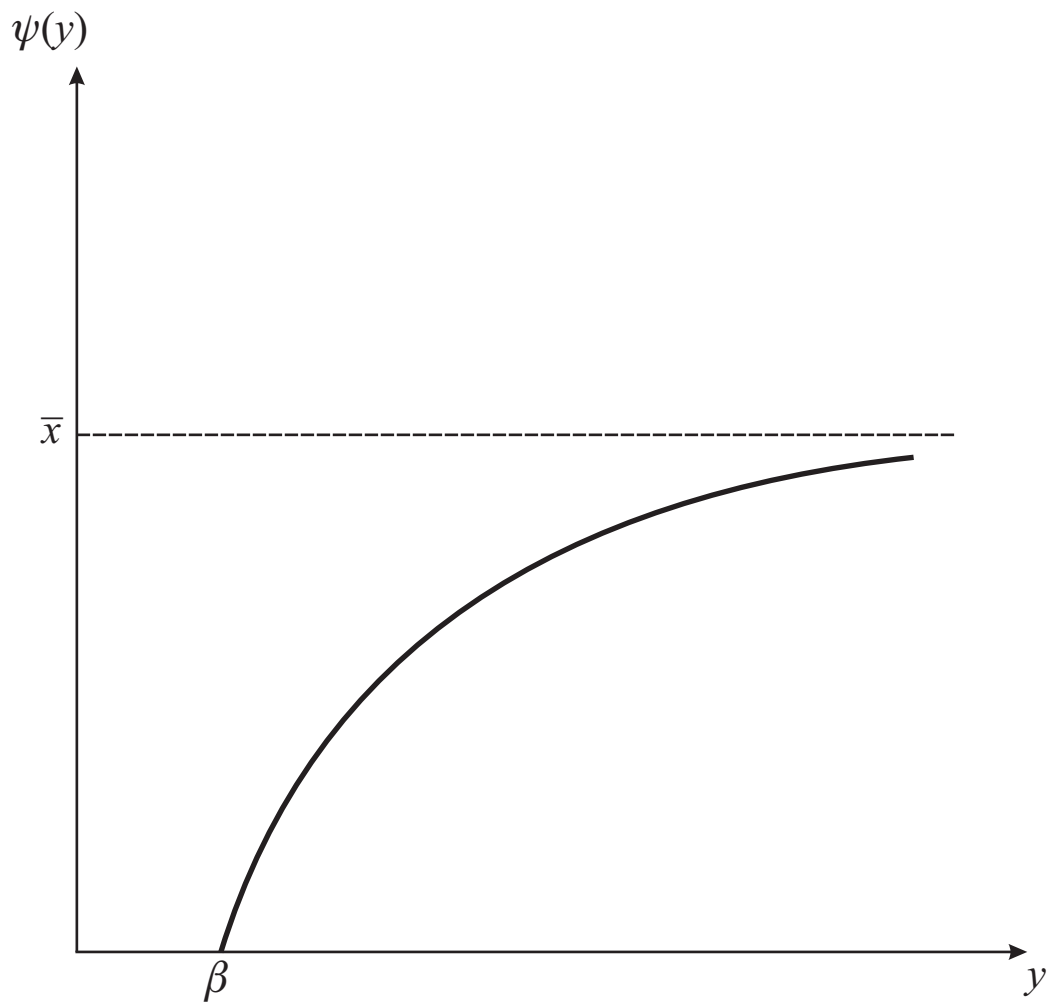

Figure 2

A Possible Function $\psi(y)$

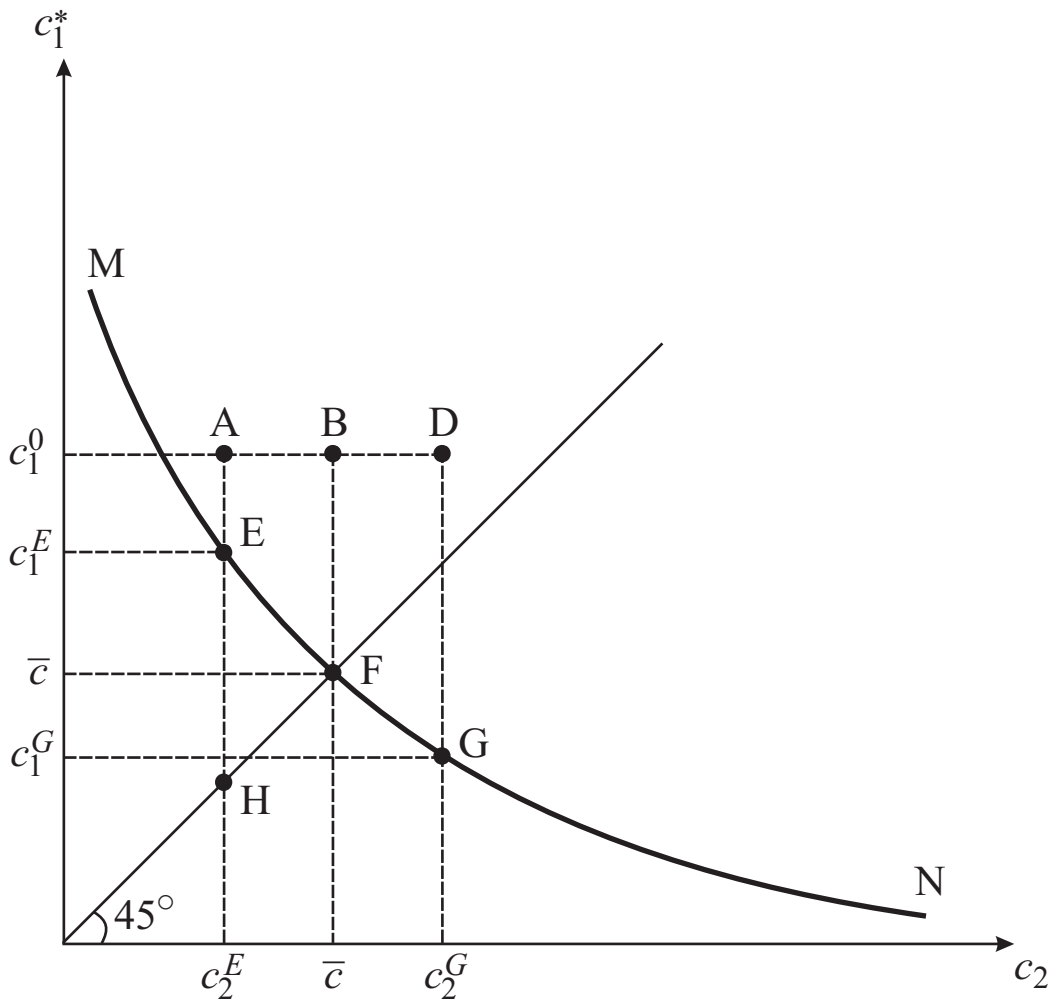

Figure 4

Relationship between the Firms' Marginal Costs

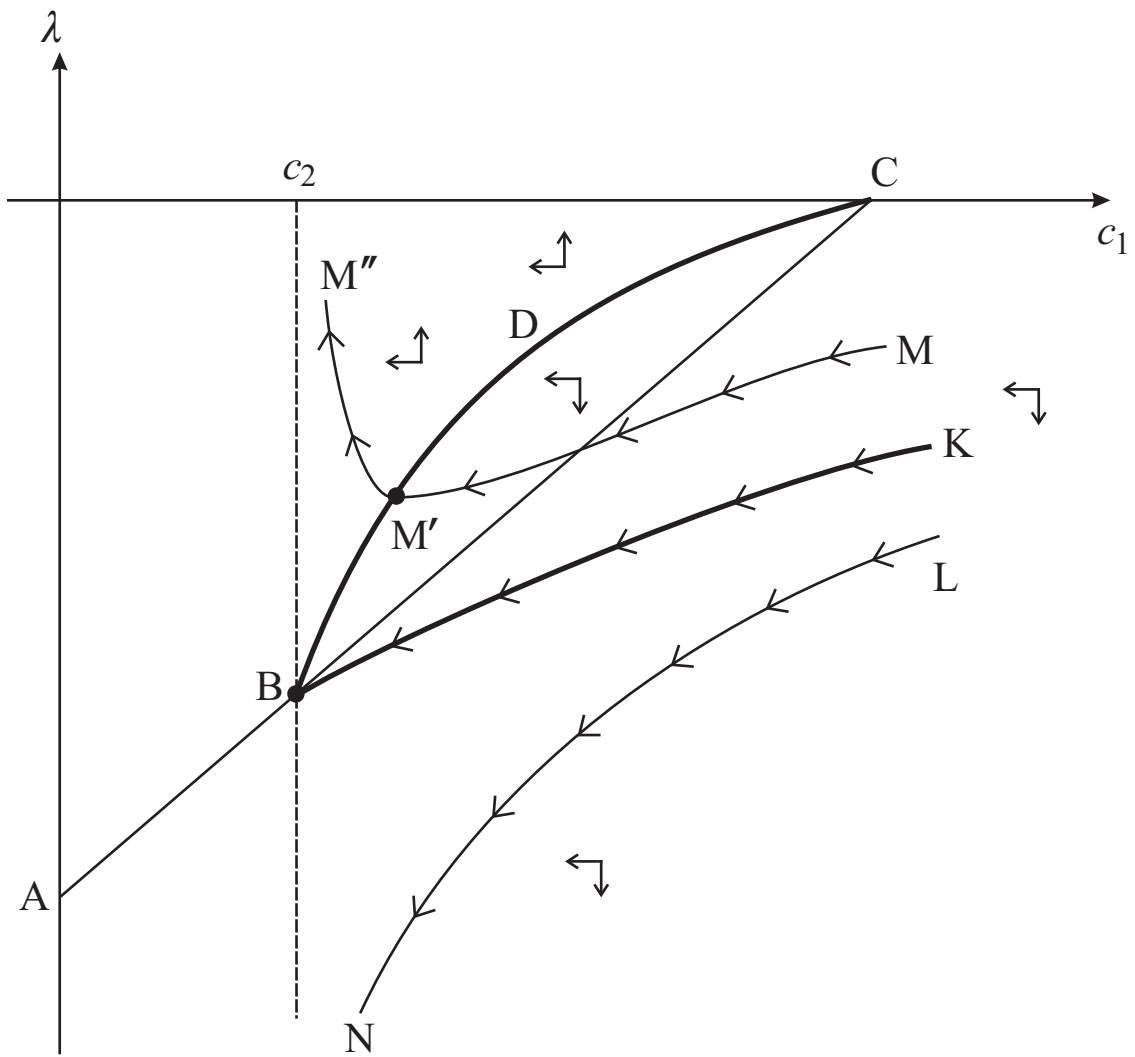

Figure 5

The Phase Diagram of Imitation

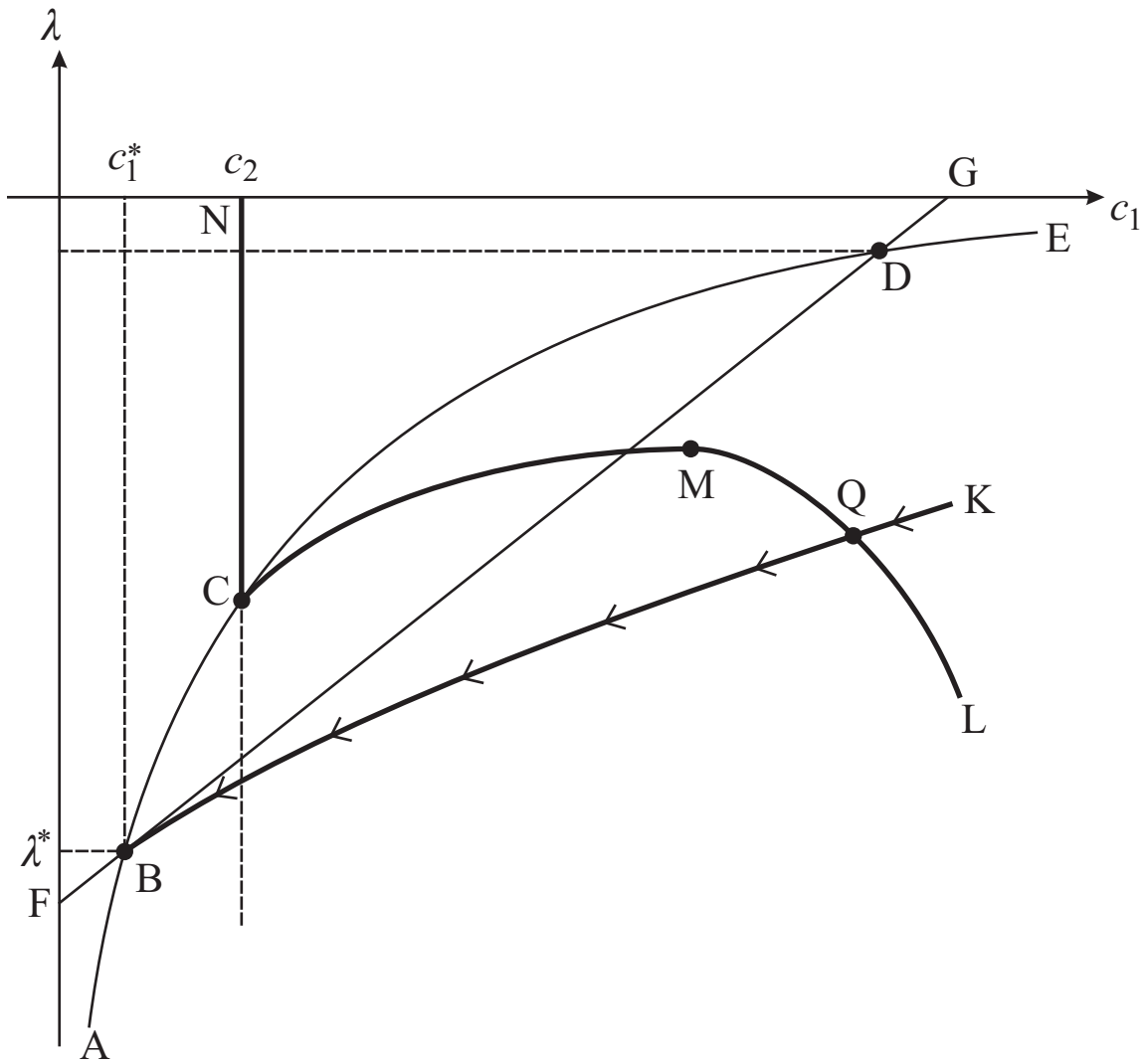

Figure 6

The Phase Diagram of Imitation/Innovation:

$$c_2 > \bar{c}$$

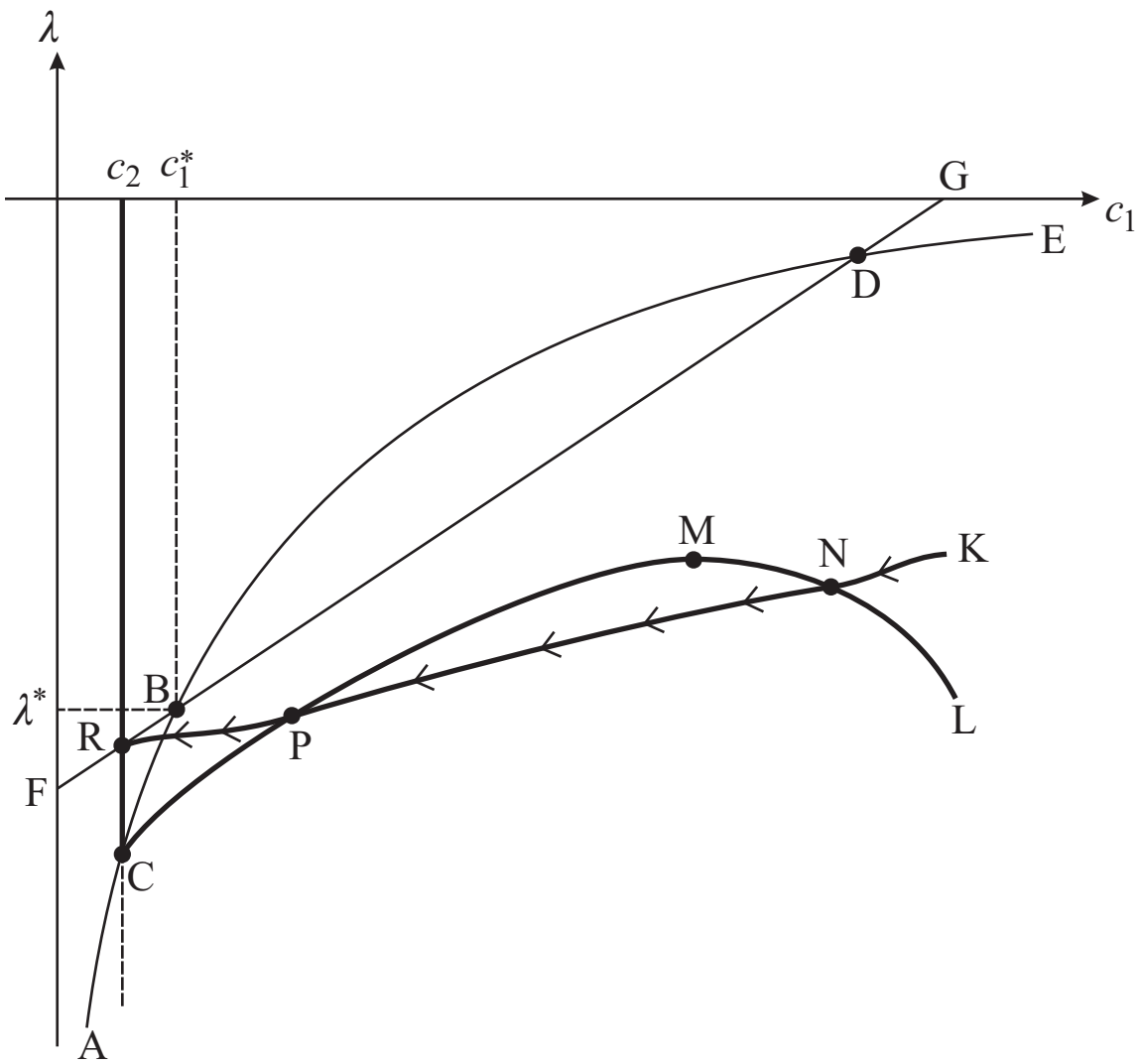

Figure 7

The Phase Diagram of Imitation/Innovation:

$$c_2 < \bar{c}$$

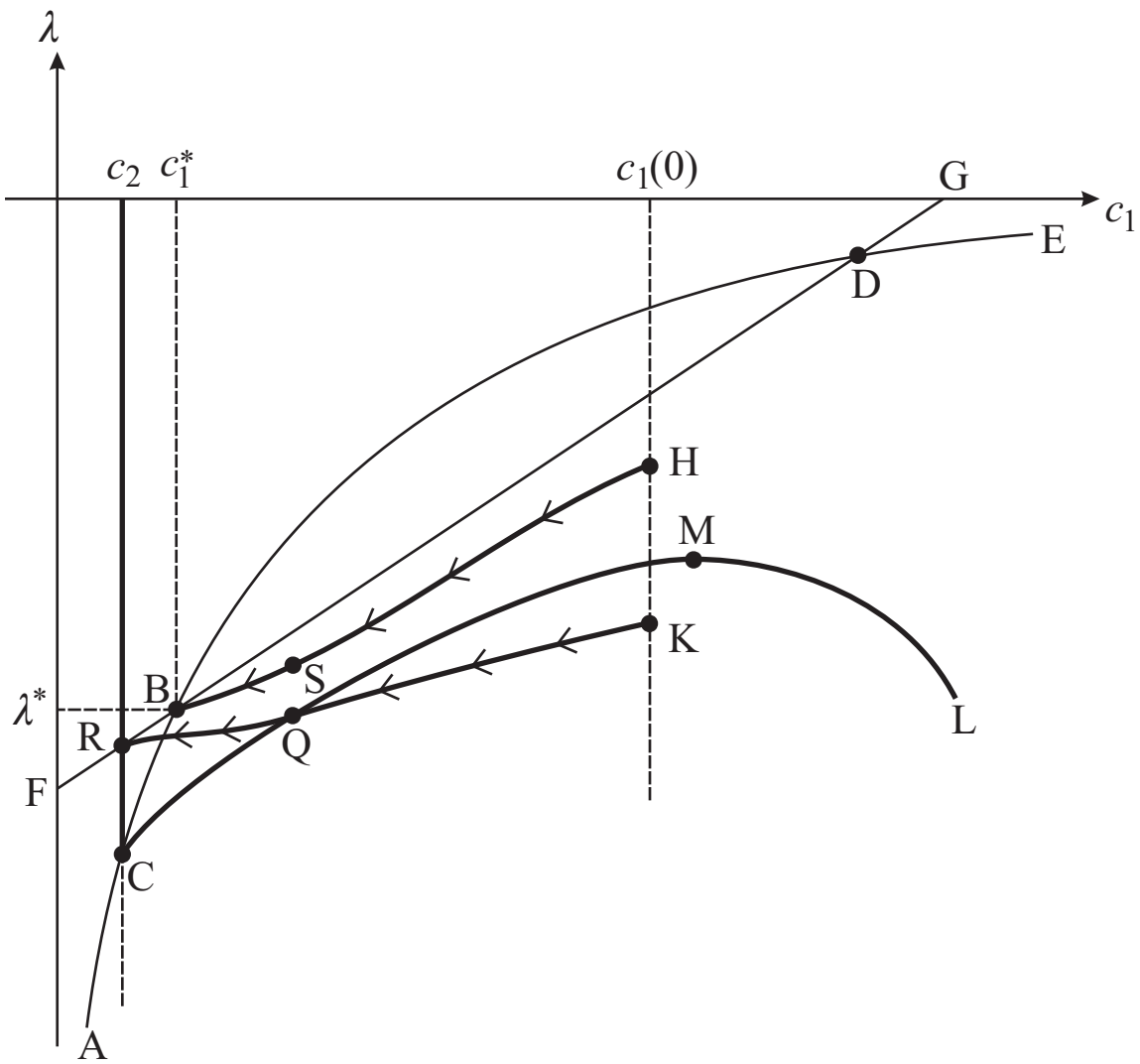

Figure 8

Innovation As A Constraint

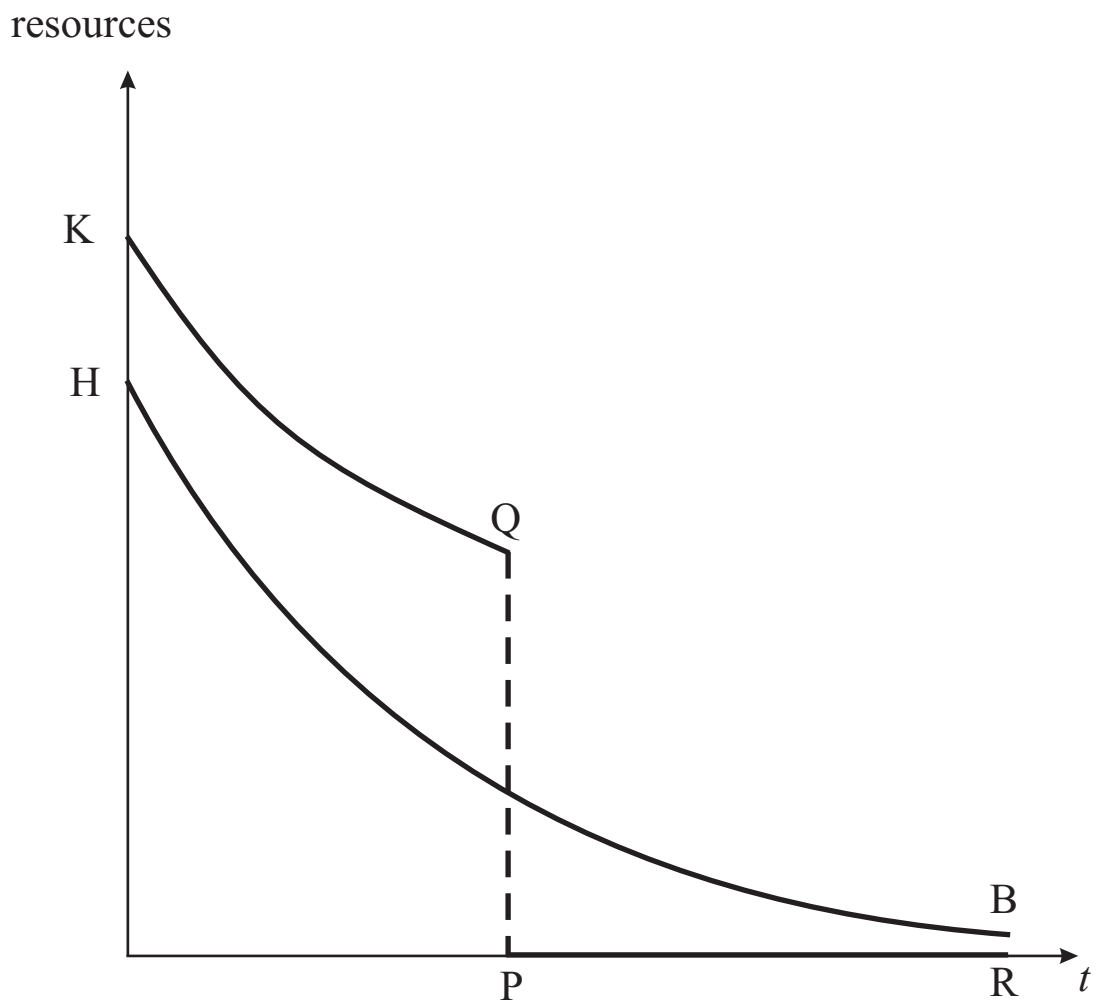

Figure 9

Resources Spent Over Time

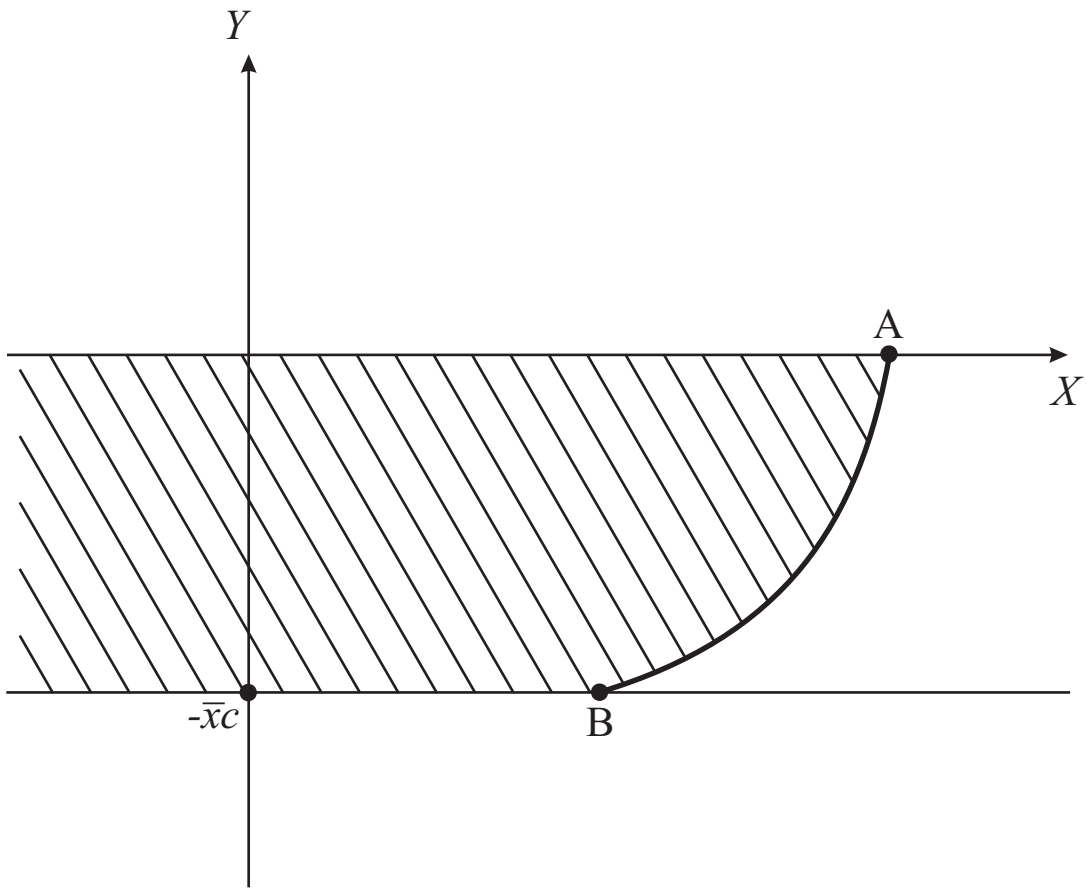

Figure A1

The Set of $N(c, U, t)$ under Innovation

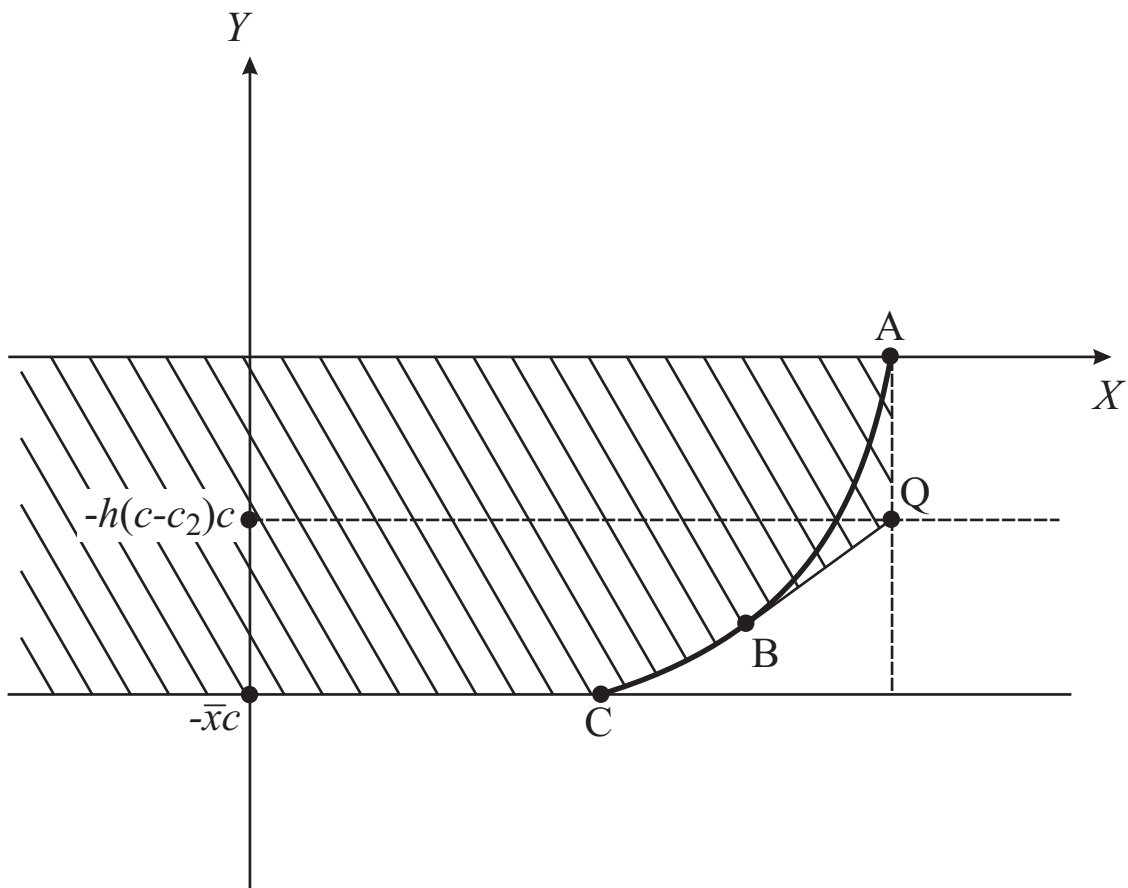

Figure A2

The Set of $N(c, U, t)$ under Imitation

References

- [1] Chipman, John (1970). “Induced Technical Change and Patters of International Trade,” in Raymond Vernon (ed.), *The Technology Factor in International Trade*, New York: National Bureau of Economic Research, 95-127.
- [2] Grossman Gene, and Elhanan Helpman (1991). *Innovation and Growth in the Global Economy*, Cambridge, Mass.: MIT Press.
- [3] Helpman, Elhanan (1993). “Innovation, Imitation and Intellectual Property Rights,” *Econometrica*, 61: 1247–1280.
- [4] Krugman, Paul (1979). “A Model of Innovation, Technology Transfer and the World Distribution of Income,” *Journal of Political Economy*, 87: 253–265.
- [5] Long, Ngo Van and Kar-yiu Wong (1997). “Endogenous Growth and International Trade: A Survey,” in Bjarne S. Jensen and Kar-yiu Wong (eds.), *Dynamics, Economic Growth, and International Trade*, Ann Arbor: Michigan University Press: 11–74.
- [6] Rivera-Batiz, Luis A. and Paul M. Romer (1991). “International Trade with Endogenous Technological Change,” *European Economic Review*, 35: 971–1004.
- [7] Seierstad, A. and K. Sydsaeter (1987). *Optimal Control Theory with Economic Applications*, Amsterdam: North Holland.
- [8] Solow, Robert (1956). “A Contribution to the Theory of Economic Growth,” *Quarterly Journal of Economics*, 70: 65–94.
- [9] Spencer, Barbara J., and Brander, James A. (1983). “International R & D Rivalry and Industrial Strategy,” *Review of Economic Studies*, 50: 707–722.
- [10] Wong, Kar-yiu (1995). *International Trade in Goods and Factor Mobility*, Cambridge, Mass.: MIT Press.