TDCS, OFDM, and MC-CDMA: A Brief Tutorial

VASU CHAKRAVARTHY, ABEL S. NUNEZ, AND JAMES P. STEPHENS,
AIR FORCE RESEARCH LABORATORY
ARNAB K. SHAW, WRIGHT STATE UNIVERSITY
MICHAEL A. TEMPLE, AIR FORCE INSTITUTE OF TECHNOLOGY

Abstract

This article gives a brief tutorial on transform-domain communication system (TDCS), OFDM, and MC-CDMA. The primary goal of this article is to give a detailed description of the TDCS transmitter and receiver systems and to highlight the fundamental differences relative to OFDM and MC-CDMA. The fundamental idea in TDCS is to synthesize a smart adaptive waveform to avoid interference at the transmitter instead of the more traditional mitigating of interference at the receiver. Unlike OFDM and MC-CDMA, TDCS has very little exposure in the current literature.

Introduction

The growth of wireless applications and spectral limitations are serious concerns for both the military and civilian communities. "A special spectrum task force set up by Federal Communications Commission (FCC) revealed that in many bands spectrum access is a more significant problem than physical scarcity of the spectrum" [1]. This is in part because present systems use a procedure formulated in the 1920s where different frequency bands are assigned to different users or service providers, and licenses are required to operate within those bands. To exploit unused spectrum more efficiently in dynamically changing environments, we desire a communication system that adapts to rapidly changing environmental conditions while ensuring that minimal, or at least manageable, interference is introduced to existing users [2]. Such a technology is termed *cognitive radio* (CR). The CR idea was initially introduced in a licentiate thesis entitled "Cognitive Radio: An Integrated Agent Architecture for Software Defined Radio" [3]. As stated, the main cognitive radio tasks include:

- Radio-scene analysis
- Channel identification
- Transmit power control and dynamic spectrum management

One function of the dynamic spectrum management algorithm is to select a modulation scheme that utilizes spectrum holes and adapts to the time varying conditions of the radio environment. By virtue of its flexibility and computational efficiency, orthogonal frequency-division multiplexing (OFDM) is a natural choice [1], and initial results suggest that transform-domain communication system (TDCS) is a potential candidate as well [2]. Considering the immense potential of CR in spectrum agile communication systems of the future, this article attempts to demonstrate the basic differences in the receiver and transmitter structures of the competing CR modulation schemes. Multicarrier code-division multiple access (MC-CDMA) is also included in the mix because it is also a fast Fourier transform (FFT)-based scheme, but is fundamentally different than OFDM or TDCS, as demonstrated in this article.

In a basic TDCS implementation, spectral interference and

friendly signal presence are estimated using Fourier-based or general spectral estimation techniques. Once frequency bands containing interference or other signals are identified, typically through estimation and threshold detection, those bands are effectively *notched* (removed) prior to creating the time-domain fundamental modulation waveform (FMW) using the appropriate inverse transform (e.g., inverse discrete Fourier transform, DFT). Data then modulates the FMW to generate the digitally encoded waveforms. Since the FMW is spectrally synthesized to specifically avoid interference regions, transmitted communication symbols do not contain energy at spectral interference locations, and received symbols are largely unaffected.

OFDM is a popular DFT-based technique initially proposed in the 1970s [4]. Its main use was for providing bandwidth reduction as an alternative to conventional multicarrier techniques such as FDM. OFDM has gained popularity with the emergence of wireless communications and wideband systems because of its inherent ability to compensate for multipath. In 1993 Linnartz *et al.* [4] combined OFDM with code-division multiplexing (CDM) and proposed a new modulation scheme, MC-CDMA. MC-CDMA effectively mitigates multipath interference while providing multiple access capability.

The remainder of this article is arranged as follows. The next two sections provide a brief overview of OFDM and MC-CDMA. These are followed by a detailed presentation of TDCS background and implementation. Similarities and differences between TDCS, OFDM, and MC-CDMA are then presented, followed by concluding remarks.

Orthogonal Frequency-Division Multiplexing

OFDM is a digital modulation scheme in which a wideband signal is split into a number of narrowband signals. Because the symbol duration of a narrowband signal will be larger than that of a wideband signal, the amount of time dispersion caused by multipath delay spread is reduced. OFDM is a special case of multicarrier modulation (MCM) in which multiple user symbols are transmitted in parallel using different subcarriers with overlapping frequency bands that are mutually orthogonal. The origination of MCM or frequency-division multiplexing (FDM) dates back to the 1950s and early 1960s for use in military radios.

The overlapping multicarrier technique implements the same number of channels as conventional FDM, but with a much reduced bandwidth requirement. In conventional FDM, adjacent channels are well separated using a guard interval. In order to realize the overlapping technique, crosstalk between adjacent channels must be reduced. Therefore, orthogonality between subcarriers is required.

In OFDM each subcarrier has an integer number of cycles within a given time interval T , and the number of cycles by

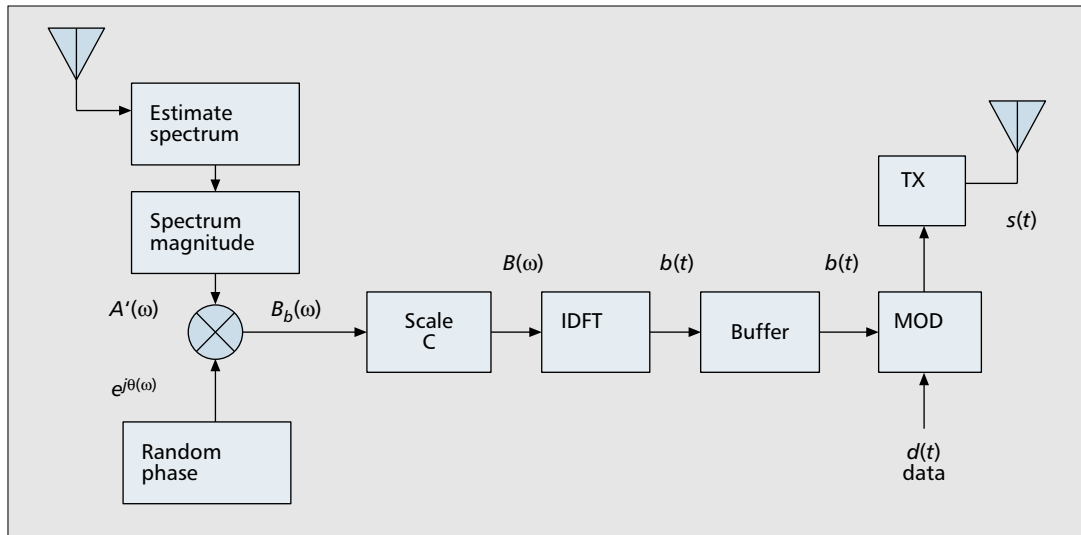

FIGURE 1. TDCS transmitter block diagram.

which each adjacent subcarrier differs is exactly one. This property ensures OFDM subcarrier orthogonality. The subcarriers are data modulated using phase shift keying (PSK) or quadrature amplitude modulation (QAM). The amplitude spectrum of each modulated subcarrier using either PSK or QAM has a sinc^2 shape. At the peak spectral response of each subcarrier all other subcarrier spectral responses are identically zero.

Following data modulation, symbols are fed through a serial-to-parallel conversion process. Each PSK or QAM symbol is assigned a subcarrier and an inverse DFT (IDFT) performed to produce a time domain signal. OFDM deals with multipath delay spread by dividing a wide band signal into N narrowband channels where N is the number of subcarriers. However, if the delay spread is longer than the symbol duration, multipath will affect performance. A guard time is introduced to eliminate intersymbol interference (ISI) caused by delay spread. As a rule, the guard time is usually two to four times larger than the expected delay spread. This can take care of ISI, but intercarrier interference (ICI) (crosstalk between subcarriers) remains an issue. To reduce ICI, OFDM symbols are cyclically extended into the guard interval. This cyclic extension ensures that an OFDM symbol will have an integer number of cycles in the DFT interval as long as the delay is less than the guard time.

At the receiver after the radio frequency (RF) and analog-to-digital (A/D) conversion stage, time and frequency synchronization between the transmitter and receiver is very crucial to the performance of an OFDM link. A wide variety of techniques have been proposed for estimating and adjusting both timing and carrier frequency. Next, a DFT is used to demodulate all subcarriers. To demodulate the subcarriers using PSK or QAM modulations, reference phase and amplitude of the constellation on each subcarrier are required. To overcome the unknown phase and amplitude ambiguities, two techniques, coherent and differential detection, are used [4].

Multicarrier CDMA

There are many possible ways to interpret and implement MC-CDMA. The approach used here to introduce it is to combine direct sequence CDMA (DS-CDMA) and OFDM. Like OFDM, the MC-CDMA signal is made up of a series of equal amplitude subcarriers. Unlike OFDM, where each subcarrier transmits a different symbol, MC-CDMA transmits the same data symbol over each N th subcarrier. MC-CDMA applies spreading in the frequency domain by mapping a dif-

ferent chip of the spreading sequence to an individual OFDM subcarrier [4].

The MC-CDMA transmitter can be implemented by concatenating a DS-CDMA spreader and an OFDM transmitter. The input data sequence is first converted into a number of parallel data sequences; then each data sequence is multiplied by a spreading code. The data in the spreading bits are modulated in the baseband by IDFT and converted back to serial data. The spreading sequence in MC-CDMA provides multiple access capability. A guard interval with cyclic extensions similar to OFDM is inserted between symbols to counter ISI caused by multipath fading. Similar to OFDM systems, MC-CDMA systems are very sensitive to nonlinear amplification and require linear amplifiers. Two parameters that affect MC-CDMA design and performance are the guard interval and the number of subcarriers.

At the receiver a coherent detection method is employed to successfully despread the signal. The received signal, after downconversion and digitization, is first coherently detected with DFT, then multiplied by a gain factor. Equal gain combining (EGC) and maximum ratio combining (MRC) are standard combining techniques used in MC-CDMA receivers. The advantage of using combining techniques is that even though individual branches may not have sufficient SNR, their combined sum increases the probability of detection by increasing the SNR of a given signal. In EGC all branches are given equal weight (unity) irrespective of signal amplitude, but the signals from each branch are co-phased to avoid signals arriving at the same time. In MRC each signal is multiplied by a weight factor depending on the signal strength. Strong signals are amplified, whereas weak signals are attenuated. Like EGC, MRC signals are also co-phased to avoid signal cancellations.

Transform Domain Communication Systems

Traditionally, communication waveforms are synthesized in the time domain using frequency allocation(s) assigned to user(s). If interference is present, it can be mitigated using real-time transform domain filtering techniques to provide interference suppression. Such techniques can be traced back to [5, 6], where primary responsibility for achieving SNR improvement rested on the receiver. Subsequent advances in processing power have enabled more computationally intense techniques [7, 8] whereby SNR improvement is achieved synergistically through transmit/receive waveform diversity to provide interference avoidance. The basic idea behind TDCS

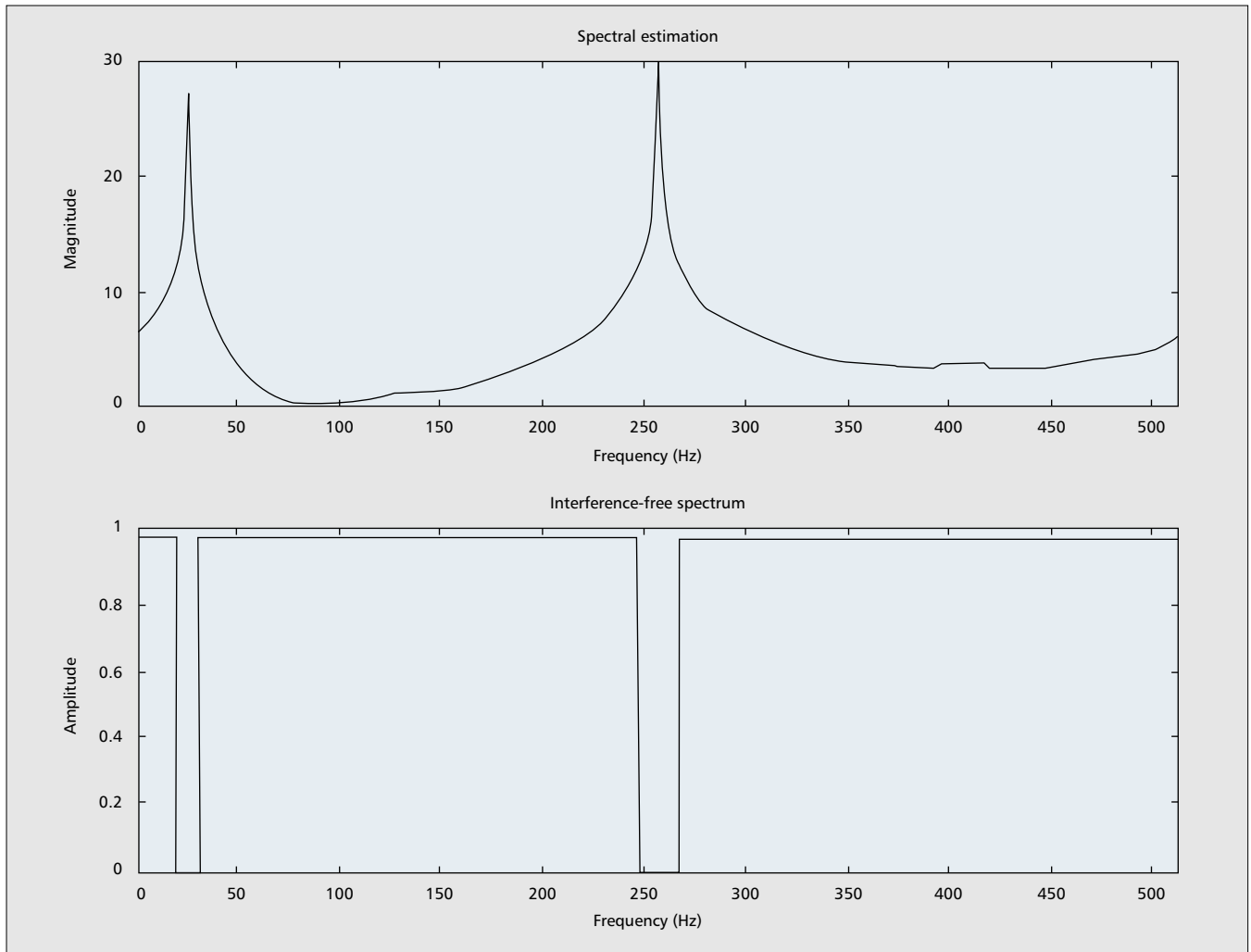

FIGURE 2. Illustration of spectral estimation (top) and corresponding notch (bottom).

FMW generation is to avoid existing users or jammers by operating dynamically over a given bandwidth. In 1988 German [8] proposed a system that uses spectral information to modify a direct sequence spread spectrum (DS-SS) waveform to avoid jammed frequencies. Subsequently, in 1991 Andren of Harris Corporation patented a conceptual low probability of intercept (LPI) communication system for hiding the transmitted signal in noise using transform domain signal processing [7]. The patent does not provide theoretical analysis or address implementation issues associated with functional processing. The Air Force Research Laboratory (AFRL) and Air Force Institute of Technology (AFIT) adopted Andren's framework for environmental sampling and waveform generation, and German's transmit signal processing [9]. Conventional time-domain matched filtering and maximum likelihood (ML) detection estimation are employed at the receiver.

The present TDCS architecture assumes that both the transmitter and receiver are observing the same electromagnetic environment, and thus produce similar spectral estimates and notches (identical estimates in the ideal case). The channel is assumed to be fixed additive white Gaussian noise (AWGN). The identical observed environment assumption is suitable for "localized" short-range data link applications where the transmitter and receiver are in the same jamming or interference environment. There are a number of scenarios where this "local" assumption is valid, such as aircraft flying in tight formation with the interference remotely located outside the formation. However, since spectral estimation is per-

formed independently at geographically separated locations, the estimates are generally not identical. This can impact transmitted symbols such that:

- They contain energy in spectral regions avoided by the receiver (loss of desired signal energy).
- They have no energy in regions retained by the receiver (increase in undesired noise).

The overall result is decreased detection of SNR and increased symbol error rate [10]. One alternate approach to independent spectral estimation is to use a dedicated feedback channel between the transmitter and receiver. This channel could be used to convey the receiver spectral environment and performance of the forward link to the transmitter [1].

Functional TDCS implementation involves environmental sampling, spectral estimation, thresholding, notching, phase generation, phase mapping, and inverse transformation to obtain the time-domain FMW. Figure 1 shows the functional flow of TDCS signal generation and transmission, beginning with environmental sampling and spectral estimation. Given that the "clean" or interference-free spectral regions are established, the FMW $b(t)$ is generated, stored, data modulated, and transmitted. Each functional block of the TDCS transmitter and receiver, and signal processing therein, is explained sequentially in the following paragraphs.

Spectrum identification (ID): Spectrum identification determines the interference-free spectral regions. If interference is due to other cooperative systems, prior knowledge can be used to establish their spectral characteristics. In noncoop-

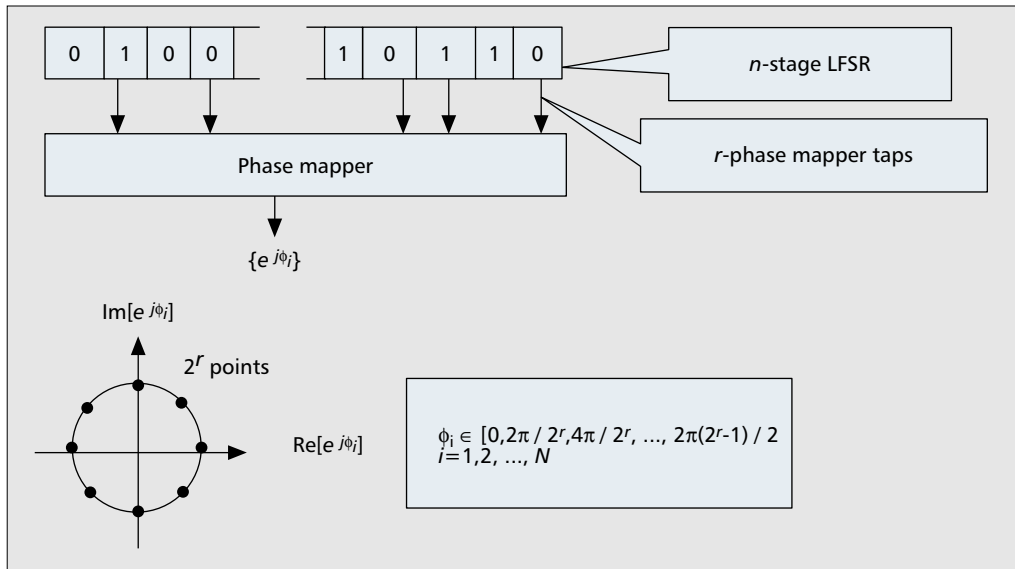

FIGURE 3. TDCS phase mapping process.

erative interference, spectral estimation techniques can be used to establish interference-free spectrum. A cooperative system is defined here as a legitimate user operating in the assigned spectral region; a noncooperative system is a jammer. Periodogram, autoregressive (AR), and wavelet-based techniques are some of the spectral estimation techniques used previously in TDCS research [10–12].

Spectrum magnitude: The spectrum magnitude is calculated from the spectral estimate. To avoid interfering frequency components, a hard limiting threshold is applied (the threshold value is usually based on the mean power contained in the spectrum). Applying a threshold to the estimated spectrum generates a “clean” or interference-free spectrum $A(\omega)$. Amplitudes of interfering frequency components exceeding the threshold are set to zero (*nulled*), and the remaining spectral components are assigned a value of one.

The top plot in Fig. 2 shows the spectral estimate of a representative environment consisting of two narrowband single-tone jammers (or other narrowband users) that produce the corresponding notched vector (interference-free spectrum) shown in the bottom plot.

Random phase: In this block a multivalued complex pseudorandom (PR) phase vector is generated for element-by-element multiplication with $A(\omega)$ to $B_b(\omega)$. The application of a PR phase vector ensures that the time domain FMW has correlation properties similar to those of sampled noise. As shown in Fig. 3, each r -bit snapshot of an m -sequence is mapped to one of 2^r complex phase values. The m -sequence serves two important functions:

- The PR phasing is critical in the development of noise-like TDCS symbols, discussed in the data modulation section.
- Multiple access is implemented by assigning each user a pair (a unique primitive polynomial) for a different m -sequence [11].

The use of PR coding and the noise-like property of FMW can lead to an erroneous impression that TDCS processing is identical to DS-CDMA. The use of PR coding in DS-CDMA is to spread the spectrum, whereas TDCS uses the PR code to randomize the phase of the spectral components.

Magnitude scaling: The complex spectrum is scaled appropriately to provide desired energy in the signal spectrum $B(\omega)$. This scaling effectively permits all communication symbols to be transmitted with equal energy (i.e., for spectrum notching due to interference, the desired energy is distributed equally among all remaining components). Note that for those applications where the peak-to-average power ratio (PAPR) of the

resultant time domain waveform is a concern, as experienced and researched in relation to some OFDM applications, several coding techniques have been developed to provide desired power relationships [4].

Although addressing the PAPR issue is beyond the scope of this article, the effects experienced by the FMWs generated from TDCS processing are believed to be similar to those of OFDM, so OFDM compensation techniques may be applicable to TDCS processing.

Inverse transform and buffer: This block generates the time-domain FMW $b(t)$ by taking the appropriate inverse transform of spectrally encoded frequency components (IDFT illustrated in Fig. 1). The resultant FMW only contains energy in interference-free regions. The FMW $b(t)$ is stored and used by the modulator for subsequent data modulation. Multiple symbols are transmitted using a single IDFT operation and generation of a new FMW is dependant upon operational requirements and environmental changes. This process differs from conventional OFDM techniques whereby a IDFT stage is required for each OFDM symbol transmission.

Modulation: Historically, TDCS work has considered two binary modulations: antipodal signaling and a form of orthogonal modulation called cyclic shift keying (CSK) [11, 13]. Antipodal modulation is a form of signaling where binary signals are the negative of each other. The CSK modulation technique takes advantage of noise-like FMW properties (i.e., correlation of time-shifted versions of the FMW with itself approaches zero). Based on this, TDCS CSK modulation uses circular shifts of the FMW to represent different symbols. For binary CSK (BCSK), the first symbol, $s_1(t)$, is the FMW itself and the second symbol, $s_2(t)$, is generated by circularly shifting the FMW over one-half its symbol period T_s . This circular shift in the time domain induces a linear phase shift in the frequency domain without affecting the magnitude. In the case of M -ary CSK (MCSK), the first symbol $s_1(t)$ is again the FMW. The j th symbol for $s_j(t)$ for $j = 1, 2, 3, \dots, M$ is generated by circular shifting the FMW by jT_s/M s, where M is the length of FMW. M -ary can be viewed as an extension of the binary case [13].

Multiple Access in TDCS

A brief discussion is provided on how TDCS accommodates multiple access capability, and simulation results are presented for the auto- and cross-correlation of two TDCS users. TDCS uses phase mapping generated from a linear feedback shift register (LFSR) configured to output a maximum-length

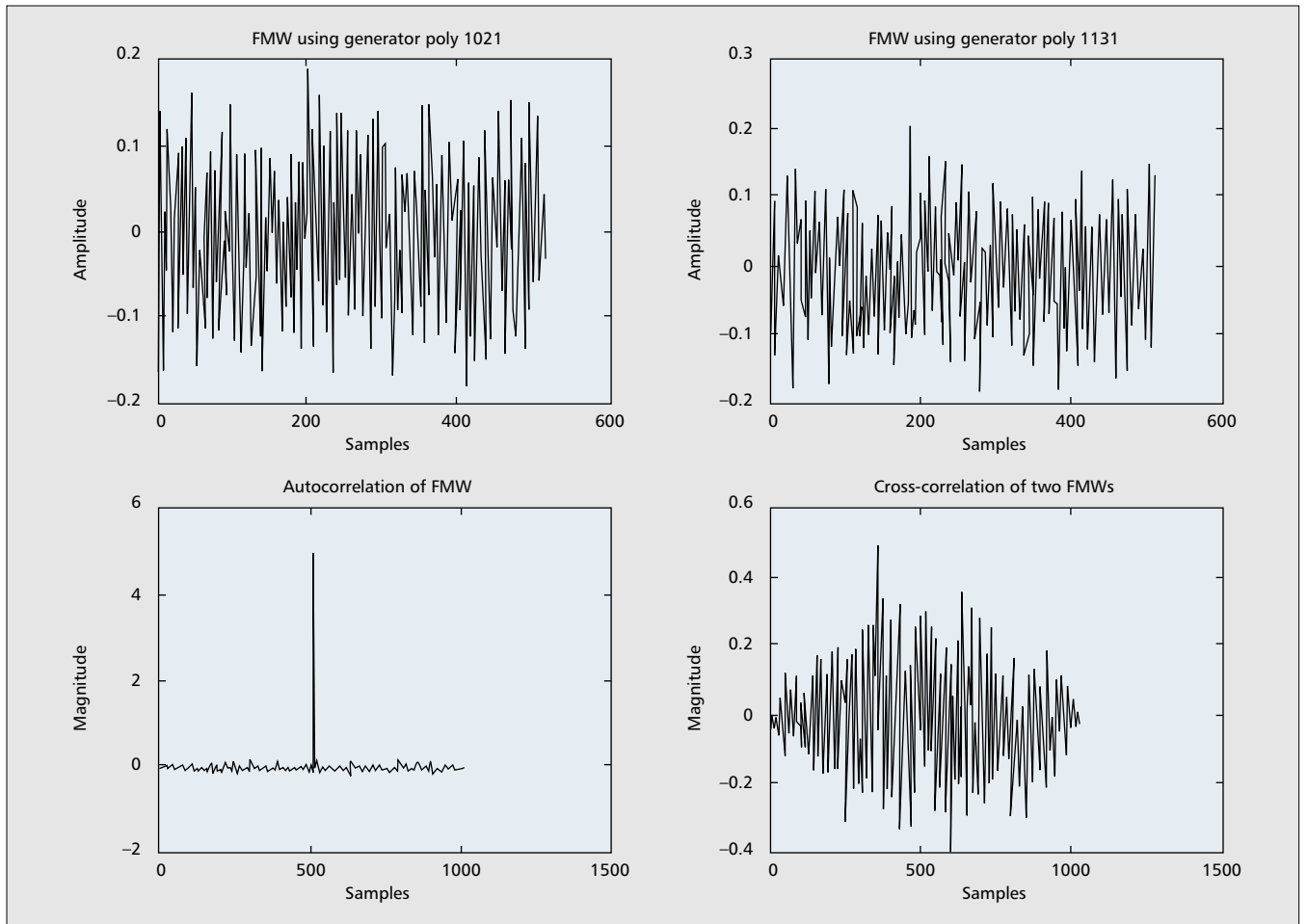

FIGURE 4. TDCS multiple access: two distinct FMWs (top plots) and resultant auto- and cross-correlations (bottom plots).

binary sequence or m -sequence. An LFSR may be configured to output several different binary sequences depending on the generator polynomial (feedback taps).

Figure 4 shows two FMWs (top plots) generated with different polynomials representing different users. The autocorrelation response is indeed impulse-like as expected for noise, and the reduced cross-correlation response between users is indicative of the quasi-orthogonal behavior required for multiple access [11].

Receiver: Received signal $r(t)$ comprises the transmitted signal $s(t)$, channel noise $n(t)$, and, if present, interference $i(t)$. As with any communication system, the first step in TDCS receiver processing prior to demodulation is acquisition, detection, and synchronization. The received signal $r(t)$ is pre-processed using either direct time correlation (DTC) or German's [8] technique. The preprocessor output is then passed to the detector for signal presence and alignment. If a signal is detected and adequately aligned, the receiver continues with estimation followed by frame and symbol synchronization [12]. The TDCS receiver demodulation structure is shown in Fig. 5 with the dotted line enclosing the identical FMW generation process used by the transmitter. Signal $r(t)$ is correlated with locally generated reference signals $c_j(T)$; for binary modulation ($M = 2$) there is one locally generated reference for each possible symbol.

Each of the M correlators generates a test statistic, $z_j(T)$. An ML decision rule is applied to the test statistic to produce a data estimate, $\hat{d}(t)$. The decision rule used is dependent on the data modulation. For antipodal modulation, if $z(T)$ is positive, $s_1(t)$ is estimated; otherwise, $s_2(t)$ is estimated. For BCSK modulation, if $z_1(t) - z_2(t) > 0$, $s_1(t)$ is estimated; otherwise,

$s_2(t)$ is estimated. Finally, for M -ary CSK the received signal is correlated with M reference signals, and the test statistic with the largest magnitude is chosen as the estimated symbol.

Differences in TDCS, OFDM, and MC-CDMA

On the surface, TDCS may appear similar in principle to both OFDM and MC-CDMA because all are DFT-based with waveforms synthesized by considering frequency domain properties. PR sequences are utilized in both TDCS and MC-CDMA generation. The PR sequence in TDCS serves two purposes:

- It randomizes the phase of the spectral components.
- It enables multiple access (MA) capability.

In MC-CDMA the PR sequence is used as a spreading code and to accommodate MA. However, the combined use of the DFT and a PR sequence creates an erroneous impression that TDCS is similar in principle to either OFDM or MC-CDMA.

• Unlike OFDM and MC-CDMA, TDCS was mainly designed to cope with intentional interference (jammers) at the transmitter and receiver instead of mitigating interference just at the receiver.

• The basic principle in OFDM is to split a wideband system into a number of narrowband subcarriers. An OFDM symbol consists of a number of subsymbols (QAM and PSK symbols). Each subcarrier contains the information for one subsymbol. TDCS uses the entire usable spectrum to represent one symbol.

• Every time an OFDM symbol consisting of N subcarriers or subsymbols has to be transmitted, it goes through an IDFT/DFT stage, while in TDCS multiple symbols or OFDM subsymbols can be transmitted using a single IDFT stage. In

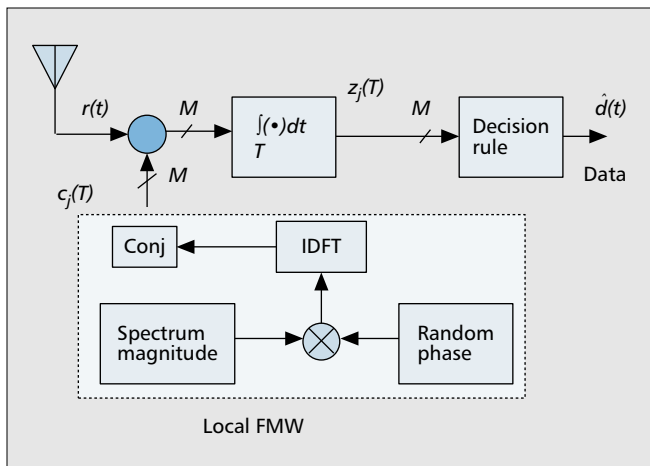

FIGURE 5. TDCS receiver block diagram.

OFDM the number of subsymbols in an OFDM symbol is fixed. The number of subsymbols per IDFT stage in TDCS is dependent on need or environment changes. For example, if the spectral environment changes hourly, a TDCS requires one IDFT stage per hour.

- Even though OFDM is a multiplexing technique, it is sometimes referred to as modulation. The underlying modulations commonly used on OFDM and MC-CDMA subcarriers are PSK and QAM. TDCS is basically an adaptive modulation technique consisting of antipodal signaling or CSK.

- In TDCS communication symbol orthogonality is achieved by randomizing the phase, which produces a “noise-like” FMW. In OFDM subcarrier orthogonality is realized by ensuring that each subcarrier contains an integer number of cycles over a given interval T and adjacent subcarriers differ by one integer cycle. In fact, OFDM does not utilize PN-code, whereas TDCS does.

- In MC-CDMA a PR sequence is used to spread the signal and facilitate MA schemes. In TDCS a PR sequence is used to provide MA capability and also provide noise-like correlation properties. It should be emphasized in particular that the purpose of a PR sequence in TDCS is not to spread the data modulated signal, but only to generate random phase used in FMW.

- In MC-CDMA spreading is done in the frequency domain by toggling the subcarrier phase between 0 and π in accordance with the spreading code. TDCS is not limited to binary phase values. The number of phase values studied thus far is up to 16 [11].

- Unlike OFDM and MC-CDMA, the originally proposed TDCS does not use carrier modulation techniques (similar to ultra wideband). However, in principle it is possible to synthesize FMWs at baseband and then apply carrier modulation to spectrally transmit the symbols.

- OFDM and MC-CDMA are essentially digital modulation techniques where the data bits or symbols modulate the FFT bin carrier frequencies directly. On the other hand, in TDCS the FFT bin frequencies do not serve as carrier bins.

Conclusions

Spectrum congestion is not mainly due to a lack of available spectrum but rather the inability to efficiently use what is available. Cognitive radio technologies along with policy changes hold a lot of promise for addressing this problem. The inherent spectrum scavenging property of TDCS, and the flexibility and frequency domain design of OFDM and MC-CDMA make all three technologies ideal CR candidates. Since all these systems are designed in the transform domain, they possess some simi-

larities. This article presents a brief overview of OFDM and MC-CDMA followed by a detailed presentation of TDCS background, and transmitter and receiver architecture. Fundamental differences between these three systems are discussed.

References

- [1] S. Haykin, “Cognitive Radio: Brain-Empowered Wireless Communications,” *IEEE JSAC*, Feb. 2005, vol. 23, no 2, pp. 201–20.
- [2] V. Chakravathy et al., “Cognitive Radio — An Adaptive Waveform with Spectrum Sharing Capability,” *IEEE WCNC*, 2005.
- [3] J. Mitola, “Cognitive Radio,” licentiate thesis, KTH, Stockholm, Sweden, Sept. 1999.
- [4] L. Hanzo et al., *OFDM and MC-CDMA for Broadband Multi-User Communications*, Wiley, 2003.
- [5] L. B. Milstein, “An Analysis of a Real-Time Transform Domain Filtering Digital Communication System — Part 1: Narrow-Band Interference Rejection,” *IEEE Trans. Commun.*, June 1980, vol. 28, no. 6, pp. 816–24.
- [6] L. B. Milstein, “An Analysis of a Real-Time Transform Domain Filtering Digital Communication System-Part II: Wide-Band Interference Rejection,” *IEEE Trans. Commun.*, Jan. 1983, vol. 31, no. 1, pp. 21–27.
- [7] A. F. Andren et al., “Low Probability of Intercept Communication System,” Harris Corp., U.S. Patent 5029 184, 1991.
- [8] E. H. German, “Transform Domain Signal Processing Study Final Report,” Tech. rep., Reisterstown, MD: Contract: Air Force F30602-86-C-0133, DTIC: ADB132635, Aug. 1988.
- [9] R. Radcliffe et al., “Design and Simulation of Transform Domain Communication System,” *MILCOM*, 1997.
- [10] M. J. Lee et al., “Wavelet Domain Communication System: Bit Error Sensitivity Characterization for Geographically Separated Transceivers,” *Proc. MILCOM 2002*, Anaheim, CA, Oct. 2002, vol. 2, pp. 1378–82.
- [11] P. J. Swackhammer et al., “Performance Simulation of a Transform Domain Communication System for Multiple Access Application,” *MILCOM '99*, Nov. 1999.
- [12] M. L. Roberts et al., “Initial Acquisition Performance of a Transform Domain Communication System: Modeling and Simulation Result,” *MILCOM 2000*, vol. 2, Oct. 22–25, 2002, pp. 1119–23.
- [13] M. J. Lee, “Wavelet Domain Communication System (WDCS): Packet-Based Wavelet Spectral Estimation and M-ARY Signaling,” Masters’ thesis, AFIT/GE/ENG/02M-14, Air Force Inst. Tech., Mar. 2001, DTIC: ADA401433, approved for public release.

Biographies

VASU CHAKRAVARTHY (vasu.chakravathy@wpafb.af.mil) is pursuing his Ph.D. in engineering at Wright State University. He received his Master’s and Bachelor’s in electrical engineering from Wright State University and the University of Illinois at Chicago in 1998 and 1988, respectively. He is presently employed as an electronic engineer at the Air Force Research Laboratory, Sensors Directorate. His research interests are algorithm development in the area of digital communications, spread spectrum systems, GPS receivers, and adaptive waveform applicable to cognitive radio.

ARNAB K. SHAW received a Ph.D. in electrical engineering from the University of Rhode Island in 1987. Since then he has been with Wright State University, Ohio, where he is a professor in the Electrical Engineering Department. His current research interests include hyperspectral image processing, digital EW receivers, and cognitive radio technologies. He has authored more than 70 technical publications. He served as an Associate Editor for *IEEE Transactions on Signal Processing* between 1998 and 2004.

JAMES P. STEPHENS has been employed as an electronics engineer with Air Force Research Laboratory, Sensors Directorate, RF Sensor Technology Division, Wright-Patterson Air Force Base, Ohio. His research activities involve both in-house and contractual efforts in communications countermeasures toward the development of concepts, systems, and supporting technologies. His focus is on spread spectrum waveforms and digital signal processing. He received an M.S.E.E. from the Air Force Institute of Technology in 1990 and a B.S.E.E. from West Virginia Institute of Technology in 1969.

MICHAEL A. TEMPLE [SM’02] is an associate professor of electrical engineering at the Air Force Institute of Technology. He received his B.S.E. and M.S.E. in 1985 and 1986, respectively, from Southern Illinois University, and his Ph.D. from Air Force Institute of Technology in 1993. His research interests include electromagnetic propagation phenomenology, adaptive interference suppression, precision emitter location, digital communications, and complex waveform generation and analysis. He has conducted sponsored research in Command, control, communications, and intelligence, radar signal/signature processing, and electronic warfare (EW).

ABEL S. NUNEZ currently works as a project engineer with the Air Force Research Laboratory, Sensors Directorate, RF Sensor Technology Division, Wright-Patterson Air Force Base, Ohio. His research activities include radar electronic countermeasures and communication waveform diversity. He received an M.S.E.E. from the Air Force Institute of Technology in 2004 and a B.S.E. from Baylor University in 1995.