



USING NEES TO INVESTIGATE SOIL-FOUNDATION-STRUCTURE INTERACTION

Sharon L. WOOD¹, Thalia ANAGNOS², Pedro ARDUINO³, Marc O. EBERHARD³,
Gregory L. FENVES⁴, Thomas A. FINHOLT⁵, Joseph M. FUTRELLE⁶, Steven K. GRANT⁷,
Boris JEREMIC⁸, Steven L. KRAMER³, Bruce L. KUTTER⁸, Adolfo B. MATAMOROS⁷,
Kurt M. MCMULLIN², Julio A. RAMIREZ⁹, Ellen M. RATHJE¹, Mehdi SAIDI¹⁰,
David H. SANDERS¹⁰, Kenneth H. STOKOE¹, and Daniel W. WILSON⁸

SUMMARY

A research program has been developed to study soil-foundation-structure interaction using the NEES infrastructure. Complementary shaking table, centrifuge, field, and laboratory specimens have been designed and testing is scheduled to begin in the summer of 2004. Comprehensive computational models are also being developed to interpret the response of the individual experiments, relate the test specimen response to the performance of the prototype system, and understand the limitations of the boundary conditions inherent to each of the experiments.

INTRODUCTION

The US National Science Foundation has invested more than \$80 million over the past five years to construct the George E. Brown, Jr. Network for Earthquake Engineering Simulation (NEES). NEES will be operational in October 2004 and has the potential to revolutionize the way that earthquake engineers conduct research and implement results into practice. The NEES infrastructure will facilitate collaborative modes of research, open exchange of information, and integration of experimental and computational simulations. This project was developed to demonstrate and challenge the new NEES

¹ Department of Civil Engineering, University of Texas, Austin, TX, USA

² Department of Civil and Environmental Engineering, San Jose State University, San Jose, CA, USA

³ Department of Civil and Environmental Engineering, University of Washington, Seattle, WA, USA

⁴ Department of Civil and Environmental Engineering, University of California, Berkeley, CA, USA

⁵ Collaboratory for Research on Electronic Work, School of Information, University of Michigan, Ann Arbor, MI, USA

⁶ National Center for Supercomputing Applications, University of Illinois, Urbana-Champaign, IL, USA

⁷ Department of Civil, Environmental, and Architectural Engineering, University of Kansas, Lawrence, KS, USA

⁸ Department of Civil and Environmental Engineering, University of California, Davis, CA, USA

⁹ School of Civil Engineering, Purdue University, West Lafayette, IN, USA

¹⁰ Department of Civil Engineering, University of Nevada, Reno, NV, USA

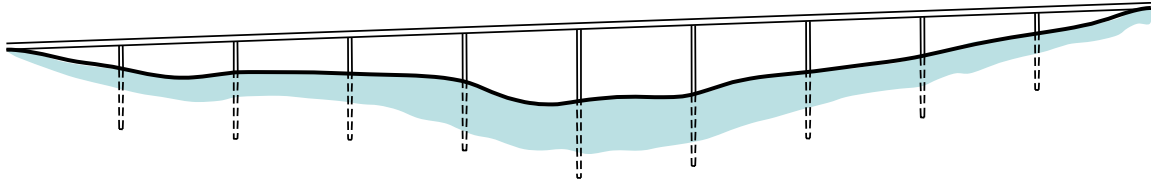

Figure 1. Prototype Structure

model for conducting research and provide important information about soil-foundation-structure interaction.

The prototype structure selected for investigation of soil-foundation-structure interaction is a continuous bridge structure (Fig. 1). Reinforced concrete, continuous bridges on drilled shaft foundations represent a common type of construction in regions of high and moderate seismicity. However, conservative design approaches for bridge foundations and the desire to eliminate inelastic structural deformations in the foundation often lead to very expensive designs for new construction or seismic rehabilitation of existing bridges. In addition, the extent to which nonlinear behavior of the soils and foundations influences the structural performance is not well defined by either documented field evidence or experimental testing.

Due to the size and complexity of the prototype system, it is impossible to test a single physical model at a reasonable scale and reproduce all key aspects of the system performance. Therefore, a series of four, complementary experimental programs have been developed to provide important data: centrifuge tests of individual bridge bents will be used to evaluate the nonlinear response of the soil and foundation system; field tests of individual bents will be used to evaluate the linear response of the soil, foundation, and structure in situ; shaking table tests of a two-span model will be used to evaluate the nonlinear response of the structure subjected to bi-directional, incoherent support motion; and static tests of bents and individual columns will be used to evaluate size effects and strength degradation in shear under cyclic loads.

Computational simulations play a central role in the project for interpreting the response of the individual experiments, relating the test specimen response to the performance of the prototype system, and understanding the limitations of the boundary conditions inherent to each of the experiments.

EXPERIMENTAL PROGRAM

The NEES experimental facilities are hosted at fifteen universities around the US. Three of these facilities will be used in this investigation. The shaking table tests will be conducted at the University of Nevada, Reno; the centrifuge tests will be conducted at the University of California, Davis; and the mobile testing equipment from the University of Texas at Austin will be used for the field tests. In addition, the structural component tests will be conducted at Purdue University. Each phase of the experimental program is described briefly below.

Shaking Table Specimen

The above-grade portion of the prototype bridge is most closely modeled by the specimen that will be tested on the shaking tables. A two-span section of the prototype has been selected for investigation (Fig. 2). The specimen represents a $\frac{1}{4}$ -scale model of the prototype. Two-column bents will support the bridge deck, and the height of the columns varies along the length of the specimen. The cast-in-place prestressed box girders in the prototype will be modeled using solid panels in the specimen.

The longitudinal reinforcement ratio in the columns is approximately 1.8%. Transverse reinforcement satisfies current AASHTO requirements for bridges located in regions of high seismic risk. Additional

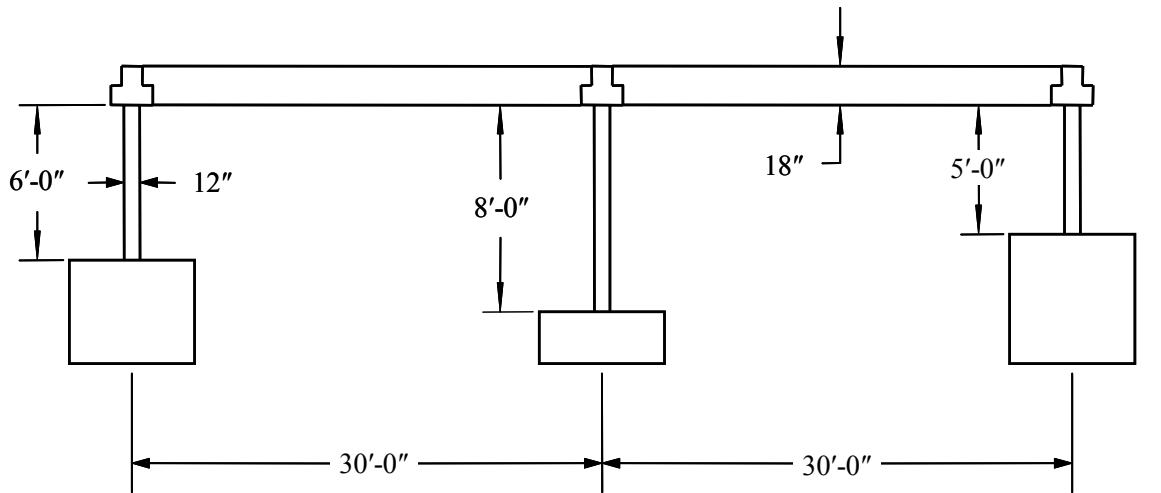

(a) Longitudinal Elevation

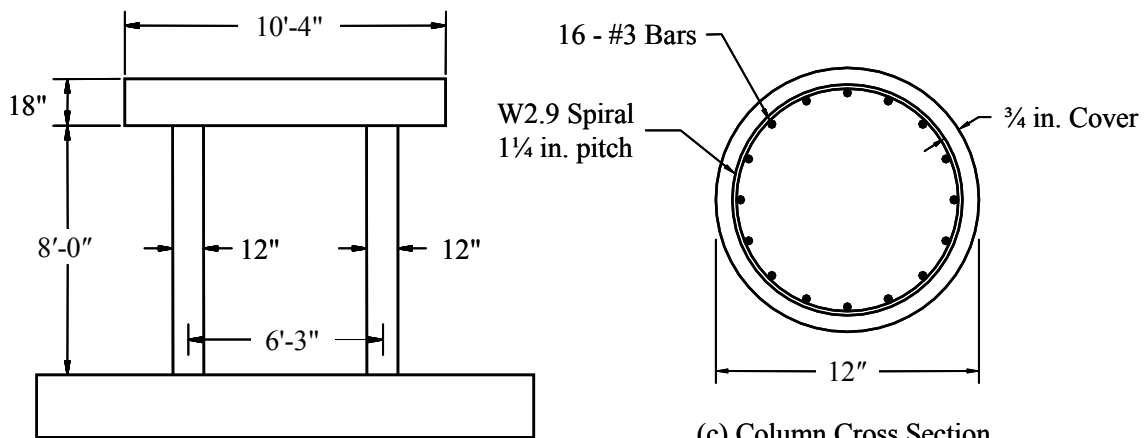

(b) Elevation of Tall Bent

(c) Column Cross Section

Figure 2. Shaking Table Specimen

mass will be added to the test specimens, such that the axial stress in the columns under dead load is approximately $0.1f'_cA_g$, where A_g is the gross area of the cross section.

The base of each column is rigidly attached to the shaking table platform (Fig. 3). Therefore, the effects of foundation and soil flexibility are not modeled explicitly in this specimen. The lengths of the columns in the model have been selected such that the clear heights represent the distance from the point of maximum moment in the shaft to the bottom of the box girder in the prototype structure.

The specimen will be subjected to earthquake ground motion of increasing intensities. Bi-directional, incoherent input motion will be used to excite the specimen at low levels of response. The transverse response of the specimen is of most interest in the inelastic range of response.



Figure 3. Shaking Tables at the University of Nevada, Reno

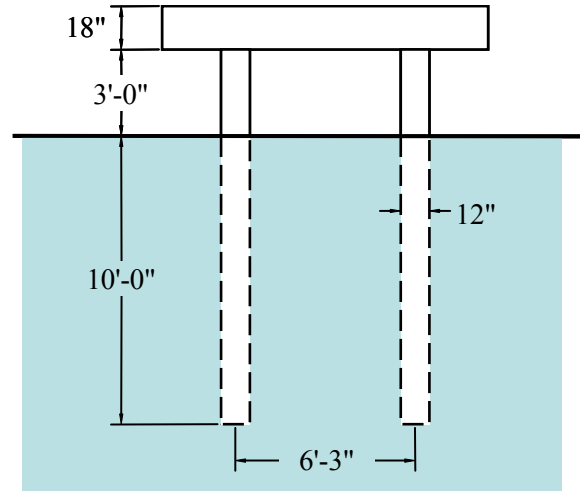

Figure 4. Field Specimen

Field Specimens

The shortest two-column bent from the shaking table specimen will also be constructed at a field site in Austin, TX (Fig. 4). The soil conditions at the site may be characterized as a silty-sand. The distance from the ground to the bottom of the bent cap in the field specimens is less than the clear height of the bent in the shaking table model because the location of maximum moment in the shaft is below grade. Additional mass will not be added to the field test specimens.

The tri-axial shaker, T-REX, shown in Fig. 5 will be used to excite the soil surrounding the tests specimens. T-REX can impose a maximum force of 30 kip on the ground in each of the two horizontal directions at excitation frequencies above 5 Hz.



Figure 5. Mobile Testing Equipment at the University of Texas at Austin

The shaker will be positioned at various locations around the test bent (Fig. 6) and will impose harmonic motion on the surface of the soil. The response of the soil and foundation are expected to remain linear in these tests. Following completion of the dynamic tests, the specimen will be subjected to static lateral forces at the level of the bent cap and pushed until a flexural hinge forms in the shaft or the soil fails. Free-vibration tests will be conducted periodically during the static tests to evaluate changes in stiffness.

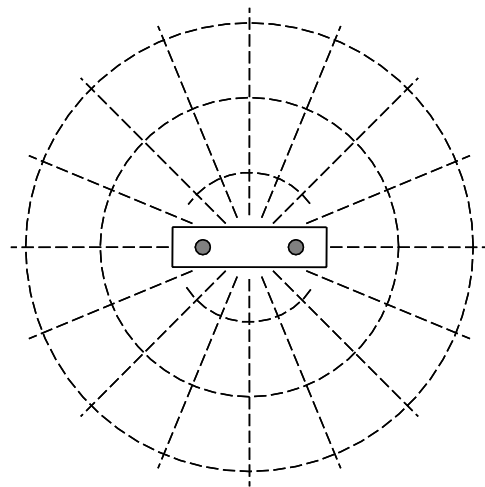

Figure 6. Loading Pattern for Field Tests

Centrifuge Specimens

Three series of centrifuge tests (Fig. 7) are planned, and each series will provide data from several test specimens. The first test series is designed to complement the shaking table tests (Fig. 8). The specimens are approximately 1/52-scale models of the prototype bents. The surface of the soil in the

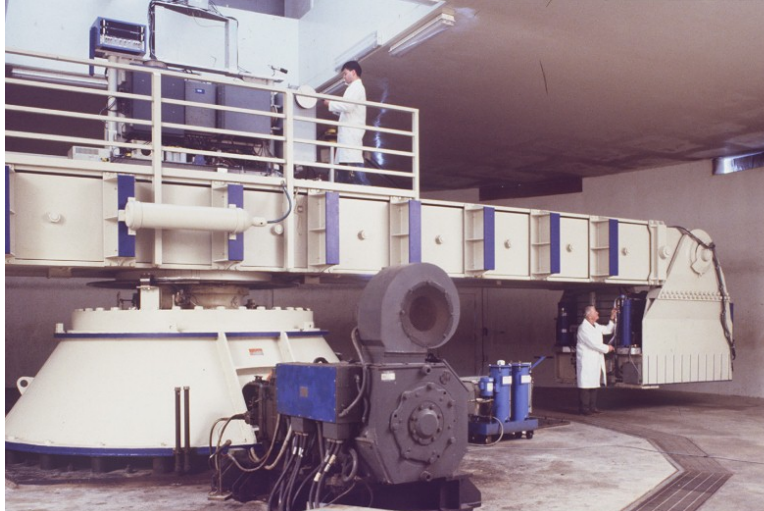

Figure 7. Geotechnical Centrifuge at the University of California, Davis

container will be varied, such that bents of different clear heights can be tested. The bents will be subjected to ground motion in the lateral direction.

The second test series is designed to complement the field tests. Some of the bents will be subjected to static lateral loads at the bent cap, while others will be excited dynamically. The third test series represents an experimental parametric study of the effects of shaft depth and stiffness.

Structural Component Tests

The structural component tests are designed to complement the shaking table studies and also investigate the influence of specimen size and amount of transverse reinforcement (Table 1). The bents will be constructed at the same scale as those tested on the shaking table and in the field, while the isolated columns will be twice as large. The amount of longitudinal reinforcement and level of axial stress will be the same in the structural component and shaking table tests. Transverse reinforcement ratios in the columns will be reduced in two specimens to induce shear failures, which represent an important mode of failure in many older bridges.

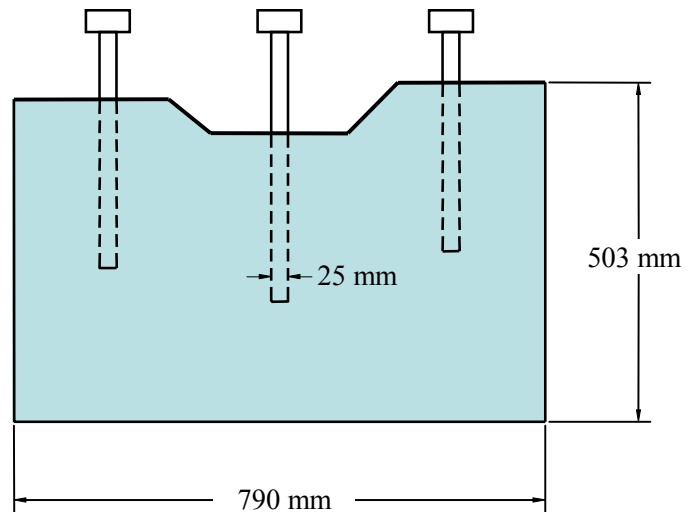

Figure 8. Centrifuge Specimen

COMPUTATIONAL PROGRAM

Computational modeling is crucial to the success of the research program, as it serves as a mechanism for integrating the response of the individual experiments. Computational models are being developed to assist with the design of the test specimens, selection of ground motions, and evaluation of the boundary conditions. The models will be used to interpret the response of the specimens, and the experimental data will be used to refine the computational models.

Table 1. Overview of Structural Component Tests

Specimen	Scale	Shake Table Element	Transverse Reinforcement
Bent 1	¼	Short Bent	Current Requirements
Bent 2	¼	Short Bent	Less than Current Requirements
Column 1	½	Short Bent	Current Requirements
Column 2	½	Tall Bent	Current Requirements
Column 3	½	Short Bent	Less than Current Requirements

The models and simulation methods for soil-foundation-structure interaction developed during this research project will also be used to evaluate the response of the prototype structure and determine the sensitivity of the calculated response to the complexity of the computational model.

The OpenSees framework, developed at the Pacific Earthquake Engineering Research Center, will be used for most of the computational work, but the research team is also using other modeling tools, as appropriate.

CONCLUSIONS

The George E. Brown, Jr. Network for Earthquake Engineering Simulation provides unparalleled access to experimental facilities, IT infrastructure, and collaborative research tools. The research team has developed a series of complementary investigations to study soil-foundation-structure interaction and evaluate the NEES model for conducting research.

Four complementary experimental programs are planned using a centrifuge, three shaking tables, mobile testing equipment, and a strong wall. Computational models play a central role in the project by providing a mechanism for integrating the response of each of the specimens and evaluating the behavior of the prototype structure. Although not discussed in this paper, the project also includes development of data standards and models for archiving the research results and development of educational modules for undergraduate and graduate students.

ACKNOWLEDGMENT

This research project is sponsored by the National Science Foundation through grant number CMS-0324326 to the University of Texas at Austin. The cognizant program officer is Steven L. McCabe. The opinions expressed in this abstract are those of the researchers, and do not necessarily reflect those of the sponsor.