

# ChemActivity 2: Lewis Structures

(How do I draw a legitimate Lewis structure?)

## Model 1: G. N. Lewis' Octet Rule

In the early part of the last century, a chemist at the University of California at Berkeley named Gilbert N. Lewis devised a system for diagramming atoms and molecules. Though simple, the system is still used today because predictions made from these diagrams often match those based on experiment.

**Lewis** proposed the following representations for the first ten elements with their **valence electrons**.

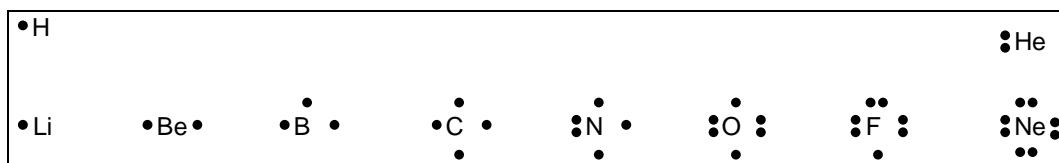

Figure 2.1: Electron Dot Representations of Elements

Only He and Ne are found in nature as shown above. All the other elements are found either as a charged species (**ion**) or as part of a **molecule** that can be represented as a legitimate **Lewis structure**.

**CHECKLIST: a Legitimate Lewis Structure** is a dot or line bond representation in which...

- I. The correct **TOTAL** number of valence electrons is shown.
- II. The sum of the valence electrons around each hydrogen atom is two.
- III. The sum of the valence electrons (bonding pairs + lone pairs) around each **carbon, nitrogen, oxygen, or fluorine atom is eight**—an **octet**. (this is the **“octet rule”**)

*Note that Lewis' rules apply to H, C, N, O and F. We will find that atoms in the next row of the periodic table (e.g., silicon, phosphorus, and sulfur) and beyond commonly violate the octet rule.*

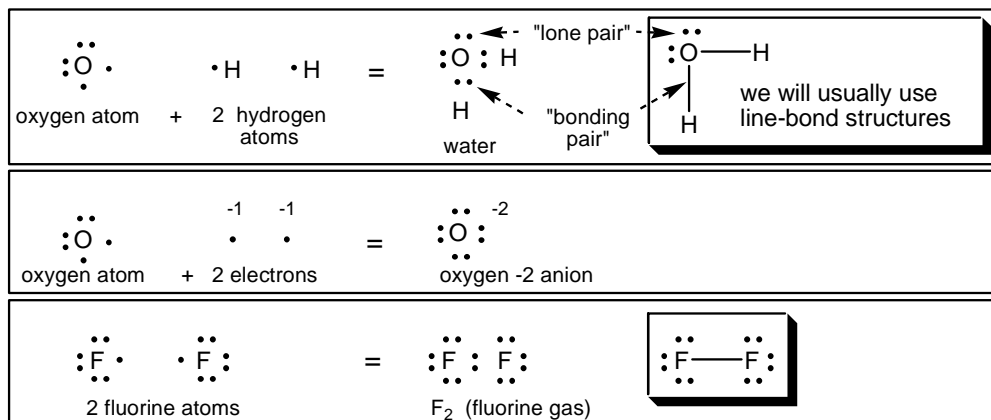

Figure 2.2: Examples of combinations that form legitimate Lewis structures

**Read this page once, and begin answering the Critical Thinking Questions on the next page.**

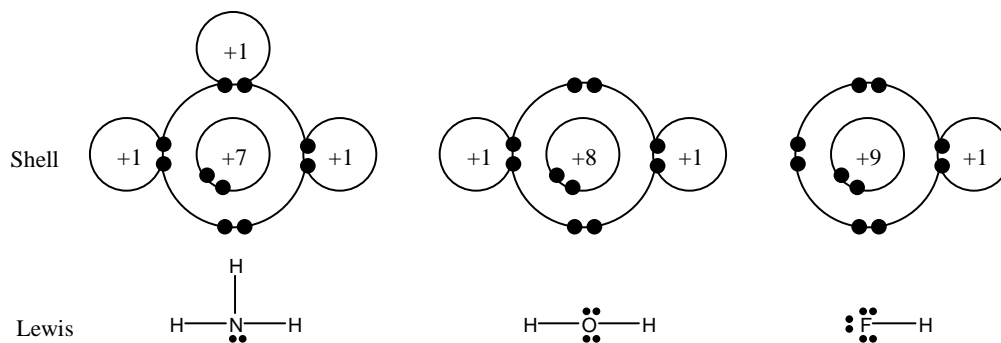

Figure 2.3: Valence Shell and Lewis Representations of Selected Compounds

### Critical Thinking Questions

- (E) Confirm that each molecule or ion in Figures 2.2 and 2.3 is a legitimate Lewis structure.
- The **valence shell** of an atom in a legitimate Lewis structure (*see* Figure 2.3) has what in common with the valence shell of a noble gas? (Noble gases are stable elements found in the last column of the periodic table, e.g., He, Ne, Ar, etc.)
- Draw a shell representation and Lewis structure for the ion of fluorine that you predict is most likely to be stable, and explain your reasoning.
- Draw a Lewis structure of a neutral molecule that you expect to be a stable and naturally occurring combination of one carbon atom and some number of fluorine atoms.
- The following structure is NOT a legitimate Lewis structure of a neutral  $O_2$  molecule.
 

- Explain why it is not legitimate.
  - Which item on the legitimate Lewis structure CHECKLIST in Model 1 is violated?

$\begin{array}{c} \cdot\cdot \\ \cdot\text{O} \\ \cdot\cdot \end{array} : \begin{array}{c} \cdot\cdot \\ \cdot\text{O} \\ \cdot\cdot \end{array}$
- It is impossible to draw a legitimate Lewis structure of a neutral  $NH_4$  molecule. Hypothetically, how many valence electrons would such a neutral  $NH_4$  molecule have *if it could exist*?
  - The +1 cation,  $NH_4^+$ , does exist. How many valence electrons does one  $NH_4^+$  ion have?
  - Draw the Lewis structure for  $NH_4^+$
- Describe how to calculate the total number of valence electrons in a +1 ion, in a -1 ion.

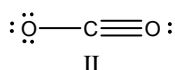
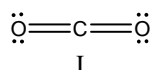
**Model 2: Two Lewis Structures for CO<sub>2</sub>**

Experiments indicate that both carbon-oxygen bonds of carbon dioxide (CO<sub>2</sub>) are identical.

**Critical Thinking Questions**

- (E) Are both structures of carbon dioxide (CO<sub>2</sub>) in Model 2 legitimate Lewis structures?
- (E) Which Lewis structure best fits experiments indicating that both C to O bonds are identical?

**Model 3: Formal Charge**

One of the Lewis structures of CO<sub>2</sub> in Model 2 is less favored because it has an imbalance of charge. To find the “hot spots” of + and – charge in a structure we must calculate the formal charge of each atom.

**Memorization Task 2.1: Formal Charge = (Group Number) – (no. lines) – (no. dots)**

- Group Number** = Column number on the periodic table (or number of dots on atom in Fig. 2.1)
- No. lines** = Number of line bonds to the atom in the structure
- No. dots** = Number of non-bonded electrons on an atom in the structure

**Critical Thinking Questions**

- (E) According to the periodic table at the end of this book, what is the **Group Number** of nitrogen?
  - (Check your work.) Does this match the number of dots on N in Fig. 2.1?
  - (E) How many line bonds are attached to N on the structure of NH<sub>3</sub>?
  - (E) How many nonbonded electrons are drawn on N in NH<sub>3</sub>?
  - Calculate the formal charge of each atom in NH<sub>3</sub>?

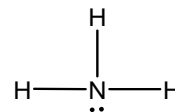

- (Check your work.) Most atoms in organic molecules (including all atoms of NH<sub>3</sub>) have a **zero formal charge**. Confirm that each atom at right has a zero formal charge.

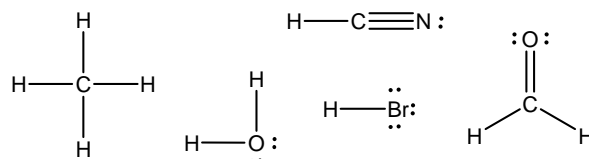

- In this course we will often encounter **+1 and -1 formal charges**, though rarely will we see formal charges of +2, -2, +3, -3, etc., because they are generally unfavorable. By convention, **only nonzero formal charges are shown on a structure**. Plus 1 and minus 1 formal charges are shown as a + or – or as a circled + or – (  $\oplus$  /  $\ominus$  ). Confirm the formal charge assignments below.

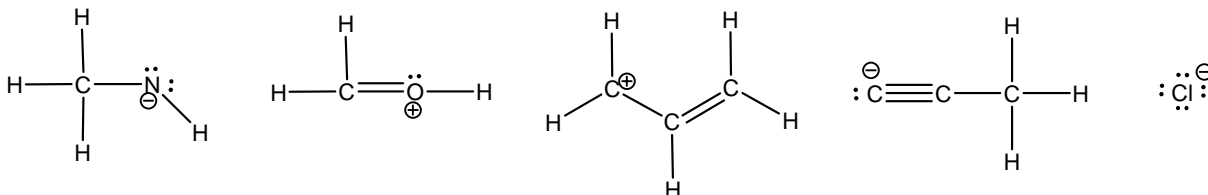

13. A complete Lewis structure must show all nonzero formal charges. Complete each of the following Lewis structures by adding any missing formal charges.

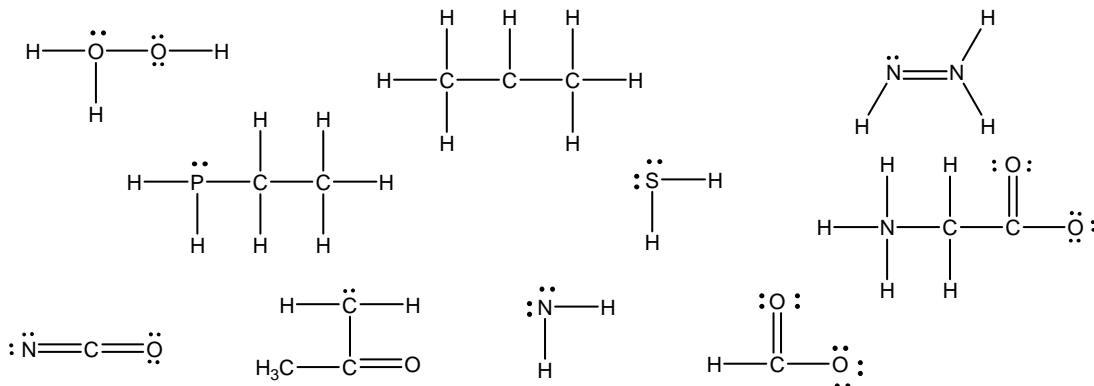

14. **Net Charge** = total charge on a molecule. (Check your work.) Structures in the top row of the previous question have a net charge of +1, structures in the middle row have a net charge of zero, and structures in the bottom row have a net charge of -1.
15. T or F: The sum of the formal charges on a Lewis structure is equal to the net charge on the molecule or ion. (If false, give an example from CTQ 13 that demonstrates this is false.)
16. T or F: If the net charge on a molecule is zero, the formal charge on every atom in the molecule must equal zero. (If false, give an example from CTQ 13 that demonstrates this is false.)
17. Identify the one Lewis structure in CTQ 13 that is NOT legitimate, and explain what attribute of a legitimate Lewis structure it is missing.

(Check your work.) *The top-center Lewis structure in CTQ 13 is a key exception to the octet rule called a carbocation. We will study carbocations extensively in the course. For reasons we will discuss later, a carbocation carbon rarely is involved in a double or triple bond. That is, a carbocation almost always has three single bonds, as shown on the next page.*

## Model 4: Condensed Structures and Using R, X, & Z as Placeholders

R, X, and Z are not elements but placeholders for atoms or groups of atoms. For example, ethanol...

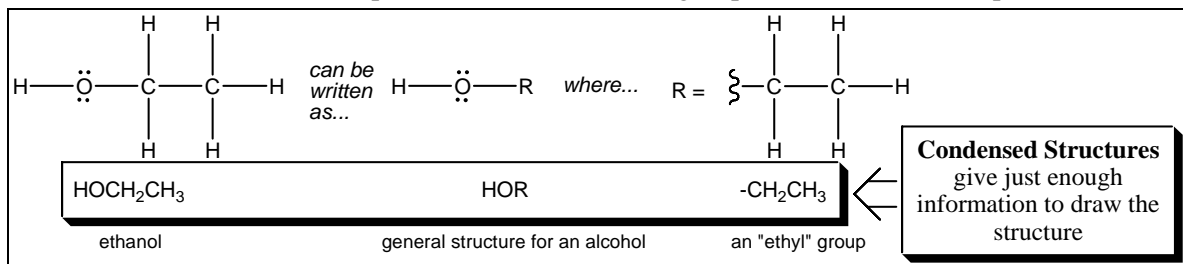

### Memorization Task 2.2: Conventions for the use of R, X, and Z as placeholders

- **R** is used to represent H or an **alkyl group**. An alkyl group is a straight or branched chain made from C and H atoms with formula  $C_nH_m$  e.g.,  $-CH_3$ ,  $-CH_2CH_3$ ,  $-C(CH_3)_3$ , etc.
- **X** is used to represent F, Cl, Br, or I (the common “halogens”)
- **Z** will be used to represent *any* atom or group of atoms

If the identity of R, X, or Z is not specified, assume a wide range of legal identities are possible. For example: in the table below, the formal charges shown hold true regardless of the identities of Z.

### Model 5: Recognizing Formal Charges for C, N, O, and X

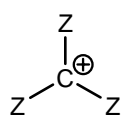
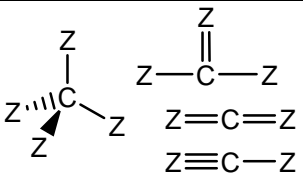
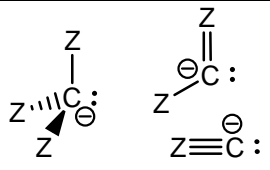
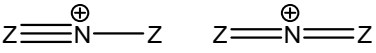
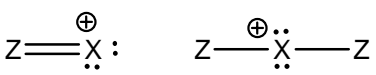
	+1	0	-1
C	 <p>Note: The two other ways to draw a carbocation are very uncommon.</p>		
N	 <p>four ways (draw the two that are missing)</p>	draw three ways	draw two ways
O	draw three ways	draw two ways	draw one way
X	 <p>two ways (less common)</p>	draw one way	draw one way (an anionic atom)

### Critical Thinking Questions

- Complete the box in Model 5 for  $N^{+1}$ , by drawing the *other* two ways an N can carry a +1 formal charge. (*Hint*: These two structures should have molecular formulas  ${}^+NZ_4$ , and  ${}^+NZ_3$ , respectively.)
- Complete the rest of the table for N, O or X by drawing the number of Lewis structures specified.
- For a legitimate Lewis structure...
  - What is the formal charge of **any** nitrogen with four bonds? ... three bonds? ... two bonds?
  - What is the formal charge of **any** oxygen with three bonds? ... two bonds? ... one bond?
  - What is the formal charge of **any** halogen (X) with two bonds? ... one bond? ... zero bonds?
- Parts a-c in the previous CTQ mean you can quickly recognize the formal charge on an N, O and X without considering non-bonded electrons (dots). Explain why a similar statement equating formal charge and number of bonds DOES NOT WORK **for carbon** (i.e., you have to look for the dots).

## Memorization in Organic Chemistry:

Memorization is a small but important part of learning organic chemistry. **Memorization Tasks** such as the one below will be clearly marked throughout this book. This is done to encourage you to memorize the critical bits of information *in* these boxes AND help you realize that you can derive everything *outside* of these boxes from the key concepts in the ChemActivity.

### Memorization Task 2.3: Correlation between No. of bonds and formal charge for C, N, O, X

Before the next class: Study the patterns in Model 5, and do practice problems until you can QUICKLY recognize the formal charge (+1, 0, or -1) of any C, N, O or X in a structure without counting.

For example, an N with four bonds should look “wrong” without a +1 formal charge; and an N with two bonds should look “wrong” without a -1 formal charge. (Write a similar rule for oxygen!)

Note that for carbon you must count the number of bonds AND check whether there is a lone pair on C. That is, a C with three bonds and no lone pair should look “wrong” without +1 formal charge; and a C with three bonds and one lone pair should look “wrong” without a -1 formal charge.

## Exercises

- Make a checklist that can be used to determine if a Lewis structure is correct and that it is the best Lewis structure.
- Turn back to Model 2, and add any missing formal charges to each Lewis structure of CO<sub>2</sub>.
  - Based on the concept of formal charge, which is the better Lewis structure for CO<sub>2</sub> (in Model 2), Lewis structure I or Lewis structure II? Circle one, and explain your reasoning.
  - Is your choice consistent with the experimental data?
- Shown below are two possible Lewis structures for the amino acid called glycine.

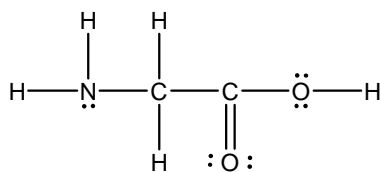

Structure I

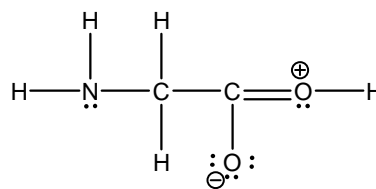

Structure II

- Predict the  $\angle\text{COH}$  bond angle based on the Lewis structure on the left.
  - Predict the  $\angle\text{COH}$  bond angle based on the Lewis structure on the right.
  - Which prediction do you expect to be more accurate? Explain your reasoning.
- Draw the Lewis structure of a neutral molecule that is a naturally occurring combination of hydrogen atoms and one sulfur atom. What is the shape of this molecule?



11. Below each structure in the previous question is a “condensed structure” that tells you something about how the atoms are arranged. Draw complete Lewis structures for each of the following condensed structures. (The net charge, if any, on each molecule is given at the end.)
- |                               |                                |  |
|-------------------------------|--------------------------------|--|
| a. $\text{CH}_3\text{CH}_2^-$ | d. $\text{C}(\text{CH}_3)_3^+$ | g. $\text{CH}_2\text{OH}^+$<br>(two different acceptable answers)  |
| b. $\text{CH}_2\text{CH}_2$   | e. $\text{BH}_4^-$             | h. $\text{CH}_2\text{CHCHCHCH}_2^+$ which may also<br>be written as $\text{CH}_2(\text{CH})_3\text{CH}_2^+$<br>(more than one acceptable answer) |
| c. $\text{CH}_2\text{CCH}_2$  | f. $\text{NCO}^-$              |  |

12. For each structure in the previous two questions, predict the shape of each central atom.
13. Carbon monoxide (CO) is an example of an overall neutral molecule (net charge = 0) that has non-zero formal charges. Draw a Lewis structure of carbon monoxide (CO).
14. Explain why this Lewis structure for CO is not as valid as the Lewis structure you drew in the previous question even though it has no “hot spots” of + or – charge (formal charges).

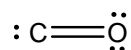

15. Give an example of a molecule appearing in this activity that is an exception to the octet rule. (Remember that the octet rule applies only to C, N, O and F.)
16. The following questions refer to the table in Model 5.
- Is there a box that has N with three bonds and no lone pairs?
  - Is there a box that has O with three bonds and no lone pairs?
  - Explain why the following is true: To determine the formal charge of a carbon in a structure you must consider *both* the number of bonds AND whether there is a lone pair, whereas for N or O you need count only the bonds.
17. Carbon is a little strange in that it does not always follow the octet rule. We will learn about this later in the course. For now know that:
- C with three bonds and a lone pair must have a –1 formal charge.
  - C with three bonds and no lone pair must have a +1 formal charge.
- Draw an example of a molecule containing a carbon with a –1 formal charge.
  - Draw an example of a molecule containing a carbon with a +1 formal charge.

18. Which of the following ions are you more likely to encounter in this course? Explain your reasoning

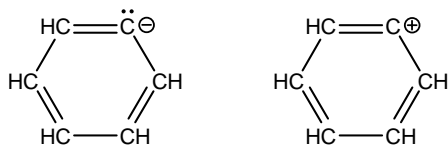

19. Complete each Lewis structure shown below.

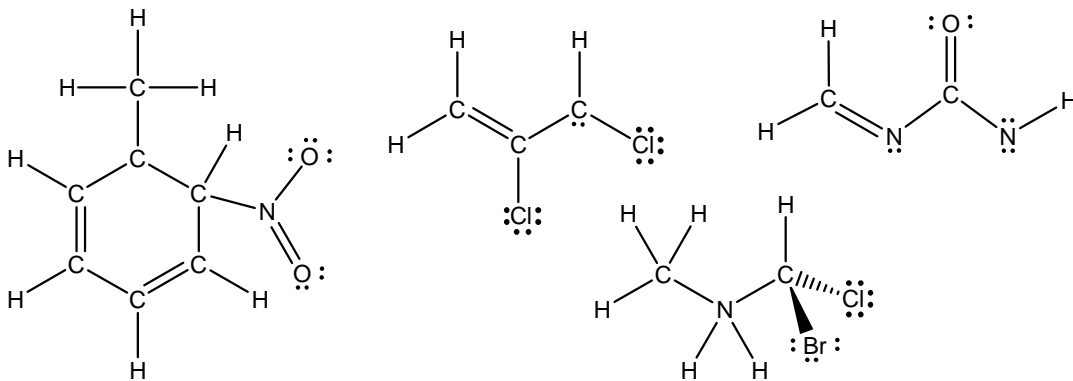

20. Read the assigned pages in your text, and do the assigned problems.

## The Big Picture

Checking for an octet and assigning a formal charge can be done by counting, but this is very slow. These operations must become second nature so that you can quickly determine **formal charge** and use this information to answer a higher-level question. Students who fail to familiarize themselves with the common occurrences of C, N, O, and X with +1, 0, and -1 formal charges shown in Model 5 quickly find themselves falling behind their classmates at this critical juncture in the course. Things get more complex quickly, so invest some time now and prepare yourself.

## Common Points of Confusion

- The number one student error at this point in the course is to confuse the **TWO REASONS TO COUNT ELECTRONS** on a Lewis structure. One is to check for an octet by looking for eight electrons around an atom. The other is to determine its formal charge by counting bonds for N, O, and X and by counting bonds AND lone pairs for carbon.
- Lewis said that C, N, O, and F must have an octet. (He didn't know about carbocations.) The fact that third-row elements like sulfur and phosphorous can expand their octets is not a violation of Lewis' **octet rule**.
- Carbon is the only atom among C, N, O, or F that can exist without an octet. This is because it is the least electronegative of the four. In other words, N, O and F are so electron-greedy that they will never accept having only six electrons in their valence shell. The most common of these are called **carbocations**.